

LCD Fundamentals Using PIC16C92X Microcontrollers

Author: Rodger Richey
Microchip Technology Inc.

INTRODUCTION

This Application Note provides a basic introduction to the features and uses of Liquid Crystal Displays (LCD).

At the end of this Application Note, you should be able to answer the following questions:

- What are the basic components in an LCD panel?
- How does an LCD work?
- What are the different types of LCD panels?
- How are LCD panels driven?

WHAT ARE THE BASIC COMPONENTS IN AN LCD PANEL?

An LCD panel, or more commonly known as a piece of “glass”, is constructed of many layers. Figure 1 shows all the layers that are typically present in LCD panels. The first layer is called the **front polarizer**.

FIGURE 1: BASIC LCD COMPONENTS

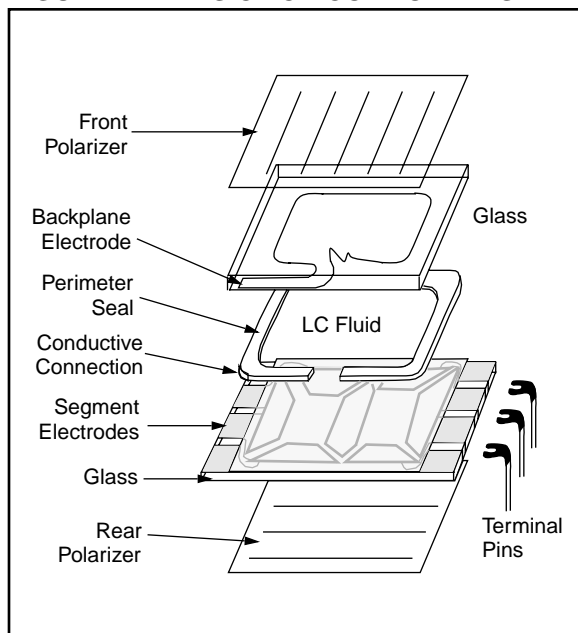

Polarization is a process or state in which rays of light exhibit different properties in different directions, especially the state in which all the vibration takes place in one plane. Essentially, a polarizer passes light only in one plane. As shown in Figure 2, if light is polarized in one plane, by passing through a polarizer, it cannot pass through a second polarizer if its plane is 90° out of phase to the first.

FIGURE 2: POLARIZERS OUT OF PHASE

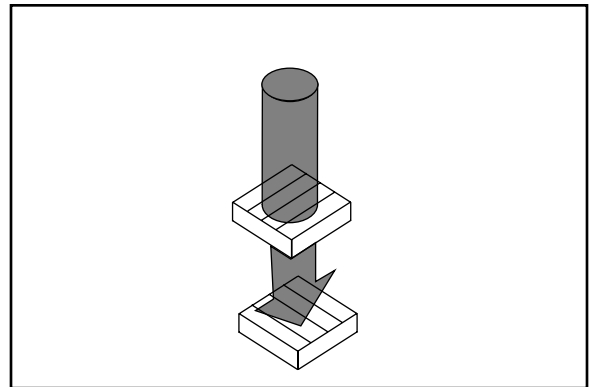

The front polarizer is applied to the outside surface of the top piece of **glass**. The top piece of glass also provides structural support for the LCD panel.

On the bottom of the top glass, a transparent coating of Indium-Tin Oxide (ITO) is applied to the glass. ITO is conductive and forms the **backplane** or common electrodes of the LCD panel. The patterns of the backplane and segment ITO forms the numbers, letters, symbols, icons, etc.

After the ITO has been applied to the glass, a thin polyimide coating is applied to the ITO. The polyimide is “rubbed” in a single direction that matches the polarization plane of the front polarizer. The action of “rubbing” the polyimide causes the Liquid Crystal (LC) molecules in the outermost plane to align themselves in the same direction.

AN658

The next layer is a reservoir of LC. The **LC fluid** has many planes of molecules.

The next layer is the polyimide coating on the bottom glass followed by the ITO **segment electrodes**. The bottom glass also supplies structural integrity for the LCD panel as well as mounting surface for the electrode connections. Applied to the external surface of the bottom glass is the rear polarizer. Depending on the type of viewing mode employed by the LCD panel, the axis of polarization is the same or 90° apart from the front polarizer.

LC molecules are long and cylindrical. On any plane within the LC fluid, the molecules align themselves such that the major axis of each molecule is parallel to all others, as shown in Figure 3. The outermost planes of LC molecules will align themselves on the same axis that the polyimide is “rubbed”. The direction of “rubbing” of the polyimide on the bottom glass is 90° apart from that of the polyimide on the top glass. This orientation creates the twist in the LC fluid.

FIGURE 3: LC MOLECULES IN ALIGNMENT

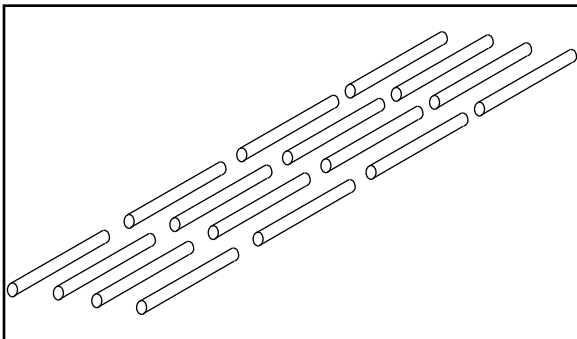

A consequence of this alignment is that each intermediate plane of LC molecules will have a slightly different orientation from the plane above or below as seen in Figure 4.

FIGURE 4: LC MOLECULES PLANE ORIENTATION

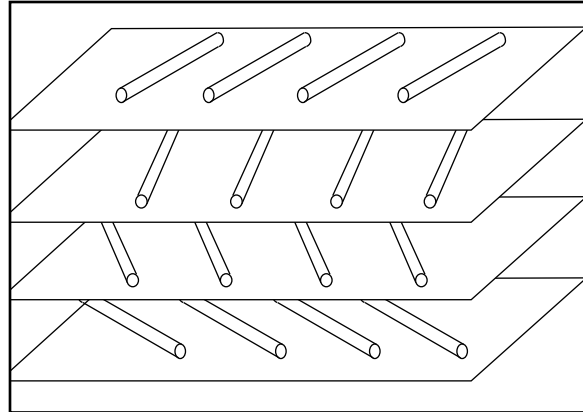

The twisting of the planes causes the polarization of the light to twist as it passes through the LC fluid. The twisting of the LC planes is critical to the operation of the LCD panel as will be shown in the next section.

Now that the mystery of what the LCD panel is made of has been uncovered, how does an LCD work?

HOW DOES AN LCD WORK?

As explained before, the twist created in the LC fluid is the basis of how the panel operates. Figure 5 shows how an LCD panel creates a pixel that is OFF. For this example the LC fluid is not energized, i.e. there is 0 V_{RMS} potential between the backplane and segment electrodes. The following is a step-by-step description of the path light takes through the LCD panel.

1. Light enters the panel through the rear polarizer. At this point the light becomes polarized to the vertical plane.
2. The polarized light passes unobstructed through the transparent backplane electrode.
3. As the polarized light passes through the LC fluid it gets twisted into the horizontal plane.
4. The polarized light passes unobstructed through the transparent segment electrode.
5. Since the light is now polarized in the horizontal plane, it passes unobstructed through the front polarizer which has a horizontal polarization.
6. The observer does not detect that the pixel is on because the light has not been obstructed.

If a potential is applied across the backplane and segment electrodes, the LC fluid becomes energized. The LC molecule planes will now align themselves such that they are parallel to the electrical field generated by the potential difference. This removes the twisting effect of the LC fluid. Figure 6 shows a pixel that is ON or, more specifically energized. The following is a step-by-step description of the path that the light takes through this LCD panel.

1. Light enters the panel through the rear polarizer. At this point the light becomes polarized to the vertical plane.
2. The polarized light passes unobstructed through the transparent backplane electrode.
3. As the polarized light passes through the LC fluid it does not twist and remains in the vertical plane.
4. The polarized light passes unobstructed through the transparent segment electrode.
5. Since the light is still polarized in the vertical plane, it is obstructed by the front polarizer which has a horizontal polarization.
6. The observer detects that the pixel is on because the light has been obstructed and creates a dark image on the panel.

FIGURE 5: PATH OF LIGHT FOR OFF PIXEL (POSITIVE IMAGE)

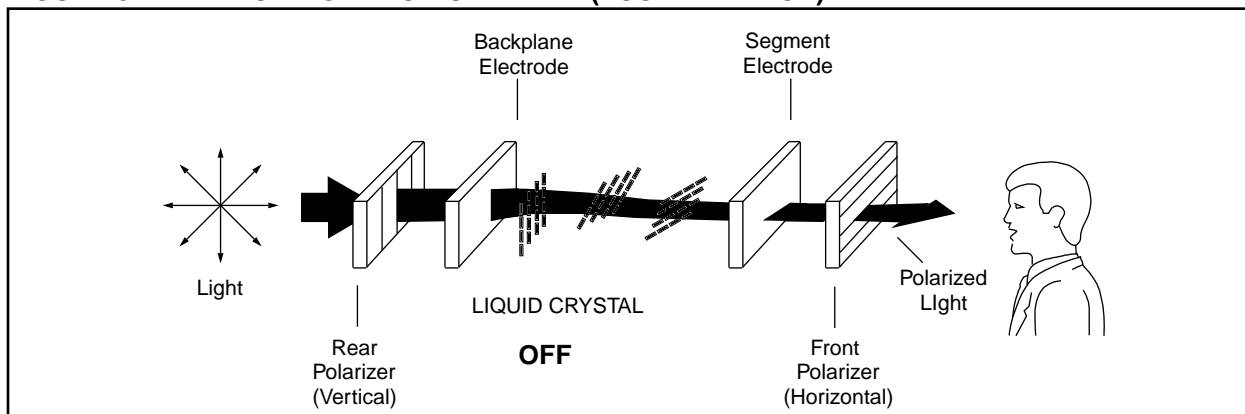
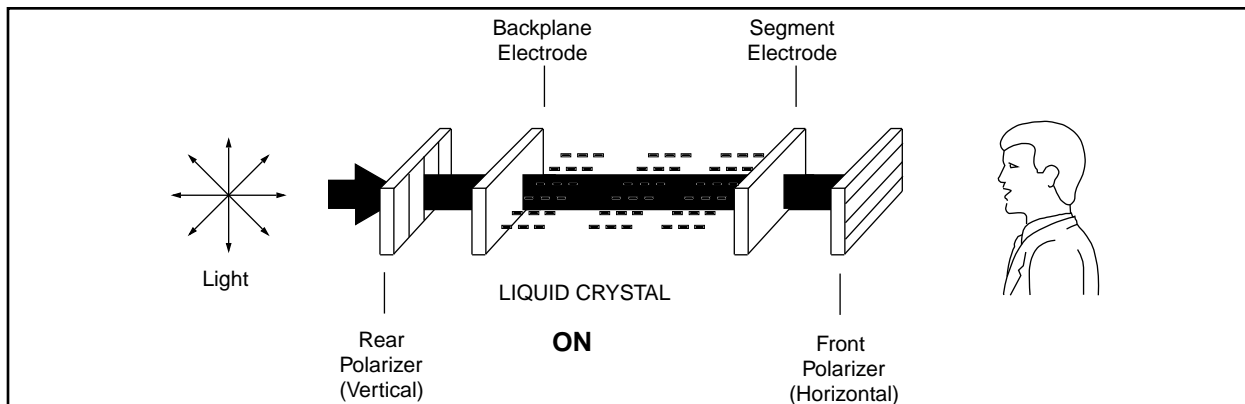

FIGURE 6: PATH OF LIGHT FOR ON PIXEL



LCD IMAGES

LCDs have the capability to produce both positive and negative images. A **positive image** is defined to be a dark image on a light background. In a positive image display, the front and rear polarizers are perpendicular to each other. Unenergized pixels and the background area transmit the light and energized pixels obstruct the light creating dark images on the light background. A **negative image** is a light image on a dark background. In this type of display, the front and rear polarizers are aligned to each other. Unenergized pixels and the background inhibit light from passing through the display. Energized pixels allow the light to pass creating a light image on a dark background.

There are essentially three types of viewing modes for a LCD: reflective, transmissive, and transreflective. Typically **Reflective displays** use only positive images. The front and rear polarizers are perpendicular to each other. The LCD panel will have an additional layer added to the bottom of the display, a reflector. Figure 7 shows the diagrams for pixels that are ON and OFF for reflective displays. Here again, the path that light takes is described in a step-by-step fashion for a pixel that is OFF in a positive image display.

1. Light enters the panel through the front polarizer. At this point the light becomes polarized to the vertical plane.
2. The polarized light passes unobstructed through the transparent backplane electrode.
3. As the polarized light passes through the LC fluid it gets twisted into the horizontal plane.
4. The polarized light passes unobstructed through the transparent segment electrode.
5. Since the light is now polarized in the horizontal plane, it passes unobstructed through the rear polarizer which has a horizontal polarization.
6. The reflector behind the rear polarizer reflects the incoming light back on the same path.
7. The observer does not detect that the pixel is ON because the light was reflected back.

A pixel that is ON follows the same basic steps except that the light never reaches the reflector and therefore does not return to the observer. Reflective displays lend themselves to battery powered applications because the images are created using ambient light sources. These displays are very bright under proper lighting conditions, with excellent contrast, and have a wide viewing angle.

FIGURE 7: REFLECTIVE LCD PATH OF LIGHT

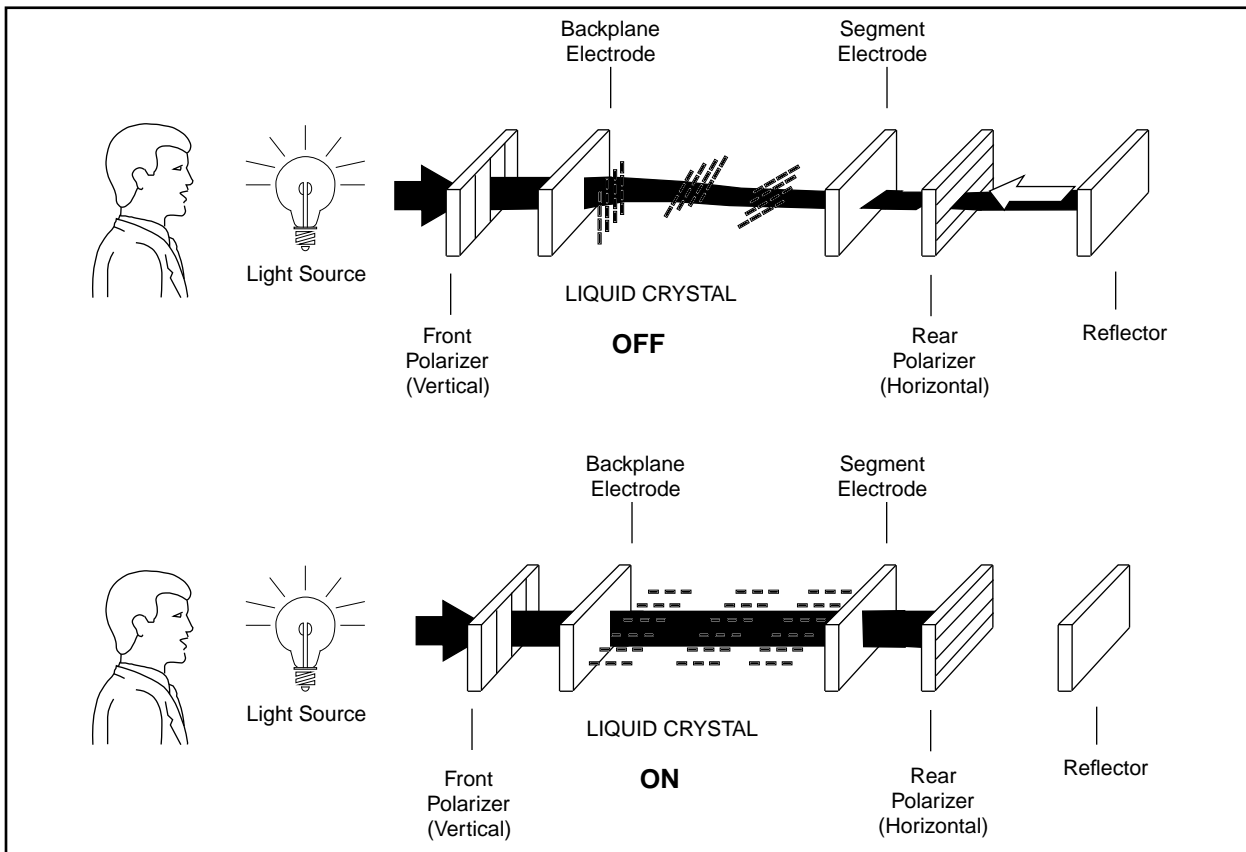

Transmissive displays do not reflect light back to the observer. Instead, they rely upon a light source behind the panel to create images. A transmissive display has front and rear polarizers that are in phase to each other. Figure 8 shows the OFF and ON diagrams for a transmissive display. The path of light is described below for the ON state only in a positive image display.

1. Light enters the panel through the rear polarizer. At this point the light becomes polarized to the vertical plane.
2. The polarized light passes unobstructed through the transparent segment electrode.
3. As the polarized light passes through the LC fluid it gets twisted into the horizontal plane.
4. The polarized light passes unobstructed through the transparent backplane electrode.
5. Since the light is now polarized in the horizontal plane, it is obstructed by the front polarizer which has a vertical polarization. Very little light passes through the front polarizer
6. The observer does not detect that the pixel is ON because the light was obstructed.

An OFF pixel would allow the light to pass through the display unobstructed because the polarization does not get twisted by the LC fluid. These displays are very good for very low light level conditions. They are very poor when used in direct sunlight because the sunlight swamps out the backlighting.

The third type of display is called **transflective**. As you can probably tell from the name, it is a combination of reflective and transmissive. A white or silver translucent material is applied to the rear of the display. It reflects some of the ambient light back to the observer while also allowing backlighting. Transflective displays are very good for applications which have varying light conditions such as gas pumps. They must operate during the day in bright sunlight, but must also operate at night. Transflective displays have lower contrast ratios than reflective displays because some of the light passes through the reflector.

FIGURE 8: TRANSMISSIVE LCD PATH OF LIGHT (NEGATIVE IMAGE)

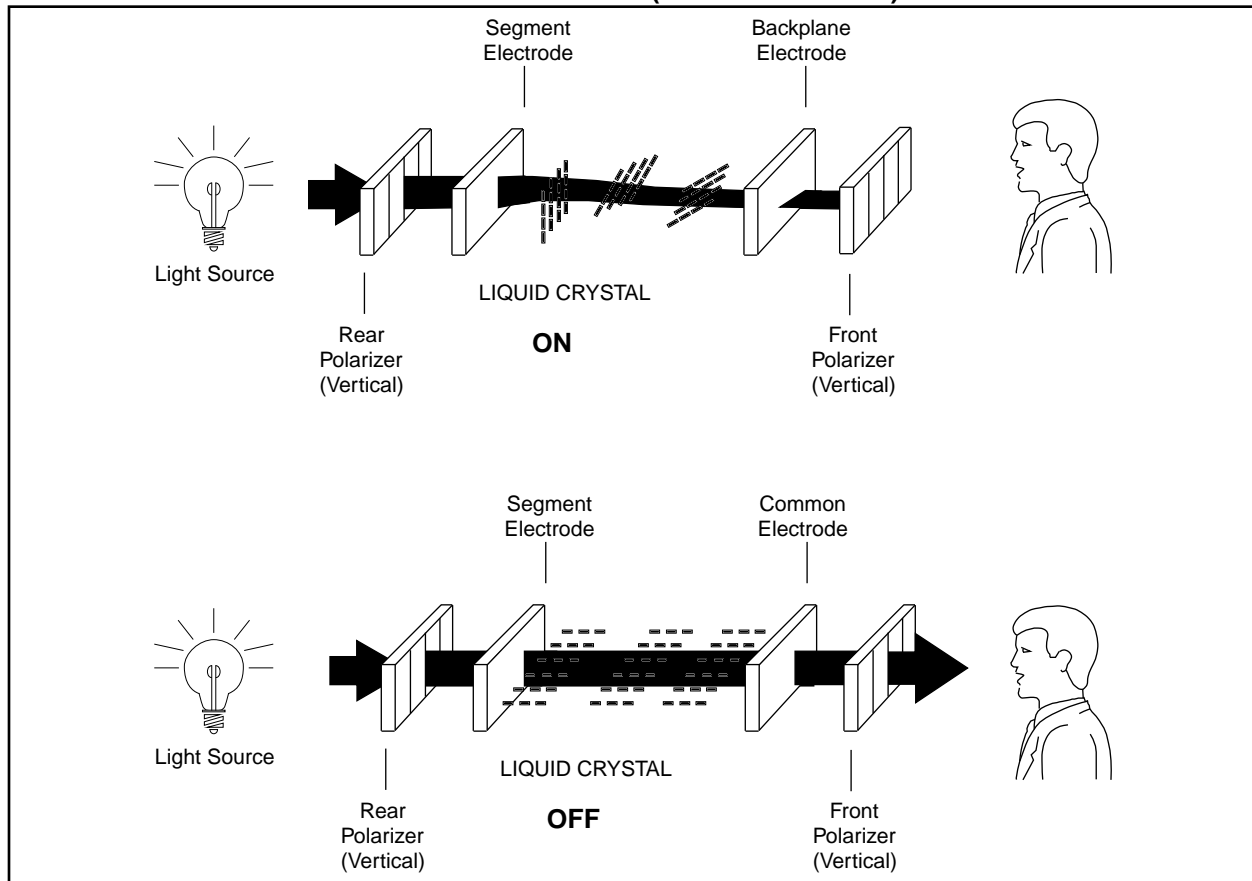

AN658

The type of LCD that an application requires is largely dependent on the ambient light available. Table 1 gives some guidelines for selecting a display according to the lighting conditions.

TABLE 1: LIGHTING CONDITION REFERENCE

Viewing Mode	Display Description	Application Comments	Direct Sunlight	Office Light	Very Low Light
Reflective (Positive)	Dark images on light background	No backlighting. Gives best contrast and environmental stability	Excellent	Very Good	Unusable
Transflective (Positive)	Dark images on gray background	Can be viewed with both ambient light and backlighting	Excellent (no backlight)	Good (no backlight)	Very Good (backlight)
Transflective (Negative)	Light gray images on dark background	Requires high ambient light or backlighting.	Good (no backlight)	Fair (no backlight)	Very Good (backlight)
Transmissive (Negative)	Backlit images on dark background	Cannot be viewed by reflection	Poor (backlight)	Good (backlight)	Excellent (backlight)
Transmissive (Positive)	Dark images on a backlit background	Good for very low light conditions	Poor (backlight)	Good (backlight)	Excellent (backlight)

DRIVER VOLTAGES

The number one cause of LCD damage is having a DC voltage applied to it. A DC voltage will deteriorate the LC fluid such that it cannot be energized. The LCD driver waveforms are designed to create a 0 Vdc potential across all pixels. The specifications for a LCD panel will include some RMS voltages such as V_{OFF} and V_{ON} . A third voltage is V_{TH} which is the RMS voltage across an LCD pixel when contrast reaches a 10% level. Often this voltage is used as V_{OFF} . V_{ON} is defined as the RMS voltage applied by the LCD driver to the segment electrode that creates an ON pixel which is typically at the 90% contrast level. It is desirable that V_{ON} be much greater than V_{OFF} .

Figure 9 graphically represents the voltage potential versus the contrast across a pixel. The final specification for an LCD panel is the discrimination ratio which is V_{ON} divided by V_{OFF} (V_{ON}/V_{OFF}). The **discrimination ratio** specifies what type of contrast levels the LCD panel will be able to achieve. Examples of discrimination ratio calculations will be given in the section "How are LCD Panels Driven?".

FIGURE 9: CONTRAST vs. RMS VOLTAGE

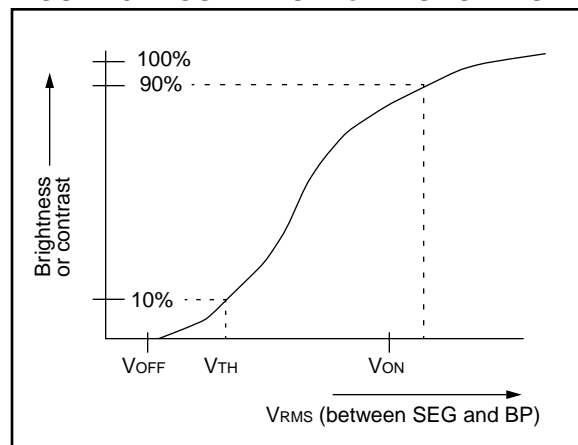

RESPONSE TIME

An LCD panel will have a typical ON and OFF response time. The **ON time** parameter refers to the time for an OFF pixel to become visible after the appropriate voltages have been applied. The **OFF time** parameter specifies the time for an ON segment to disappear. Sometimes these parameters are called rise and decay, respectively. Temperature plays a key role in the response time of an LCD panel. Figure 10 shows the response times versus temperature for commercial type LC fluid. For this reason, there are no LCD panels in gas pumps in Alaska without heaters. Displays with heaters can help to decrease response time even at temperatures as low as -55°C . The drawback of an LCD heater is that every square inch of surface on the back of the display requires 2 to 3 watts.

FIGURE 10: RESPONSE vs. TEMPERATURE

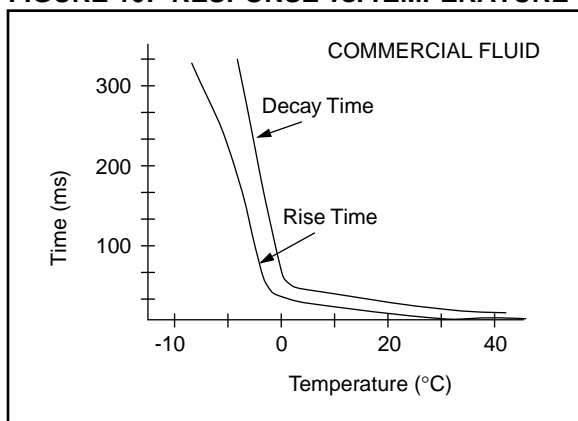

TEMPERATURE EFFECTS

As previously shown, temperature has a large impact on the performance of the LCD panel. Not only is the LC fluid affected, but the internal coatings begin to deteriorate. All LC fluids have well defined operating temperature limits. If an LCD is operated above its fluid limits, the LC molecules begin to assume random orientations. The pixels on a positive image display will become completely dark, while pixels on a negative image display will become completely transparent. An LCD can recover from these conditions if the exposure is kept short, however, temperatures above 110°C will cause the ITO and polyimide coatings to deteriorate.

On the low end of the temperature spectrum, response times increase because the viscosity of the LC fluid increases. At very low temperatures, typically -60°C , the LC fluid transitions into a crystalline state. Usually, the LC fluid can recover from the effects of low temperature. Many different types of LC fluid are available, which allows the LCD panel to be tailored to the expected operating conditions. As mentioned in the previous section, heaters can combat the effects of low temperature.

CAPACITANCE

The LCD panel can be modeled as a lossy, non-linear capacitor. The area of the pixel, and therefore the size of the LCD panel, has a direct impact on the value of the capacitance that a common or segment driver must be able to drive. Typical values of capacitance are in the range of $1000 - 1500 \text{ pF}/\text{cm}^2$. Figure 11 shows an example of a 1/3 MUX panel. As you can see the backplane driver must be capable of driving significantly higher capacitances than the segment driver.

Care must be taken when designing a system such that your LCD driver is capable of driving the capacitance on the segment and common. Otherwise the LCD panel may be damaged due to a DC offset voltage generated by overloaded segment and common drivers.

PIC16C92X microcontrollers are capable of driving backplanes up to 5000 pF and segments up to 500 pF .

FIGURE 11: 1/3 MUX LCD EQUIVALENT CIRCUIT

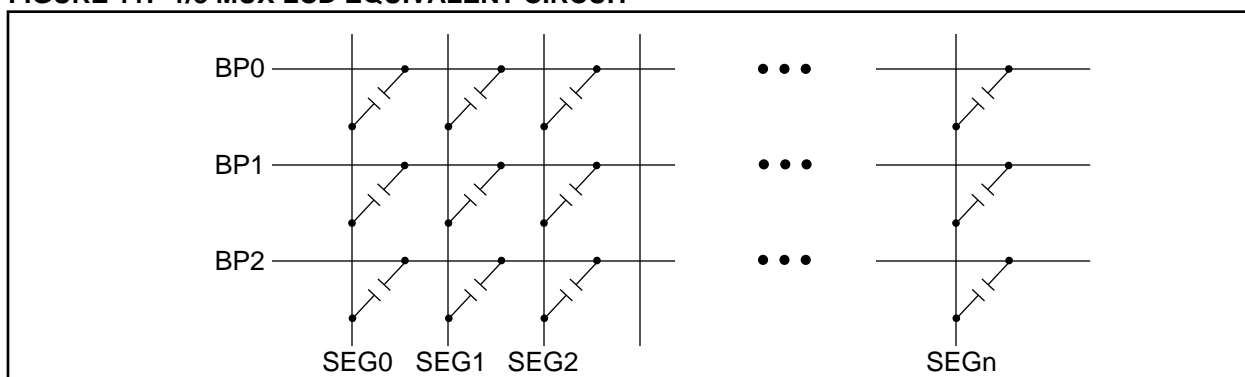

BACKLIGHTING

A variety of methods exist for backlighting LCD panels, such as, incandescent lamps, LEDs, and electroluminescent lamps. Incandescent lamps require some type of reflector to provide uniform lighting to all areas of the panel. LEDs require some type of lightguide or lightpipe to evenly distribute light. Electroluminescent lamps typically come in some type of a panel arrangement. Other lighting methods are available for specific applications, such as fluorescent. Table 2 provides a comparison of these methods of backlighting.

TABLE 2: BACKLIGHTING FEATURES COMPARISON

Feature	LED	Incandescent	Electroluminescent
Brightness	Medium	High	Low-Medium
Color	Limited	White	White
Size	Small	Small-Medium	Thin
Voltage	5V	1.5V - 28V	45V - 100V
Current @5V/sq. in	10-30 mA	20 mA	1 mA - 10 mA
Temperature	Warm	Hot	Cool
Cost/sq. in	\$0.10 - \$1.00	\$0.10 - \$0.80	\$0.50 - \$2.00
Shock Tolerance	Excellent	Fragile	Excellent
Life (hours)	100,000	150 - 10,000	500 - 15,000

CONNECTION METHODS

The first method of connecting the LCD panel to the world was the dual-in-line pin shown in Figure 12.

These pins provide excellent protection for harsh environments, vibration or shock. The LCD panel is either soldered directly to the printed circuit board (PCB) or inserted into headers.

FIGURE 12: DUAL IN-LINE PINS

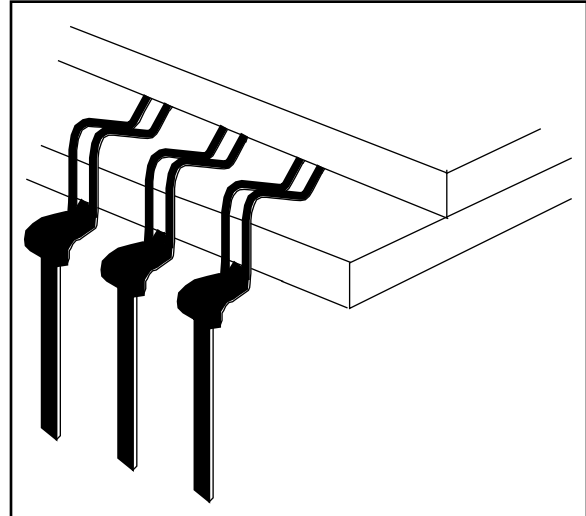

The second method is elastomeric connectors. This method allows fast assembly/disassembly without having to solder the LCD panel. Elastomeric connectors are used on small applications where space is a concern. These connectors are relatively resistant to shock and vibration, but special consideration must be used when the panel will be exposed to harsh environments. Figure 13 shows an assembly drawing of an elastomeric connector.

FIGURE 13: ELASTOMERIC CONNECTORS

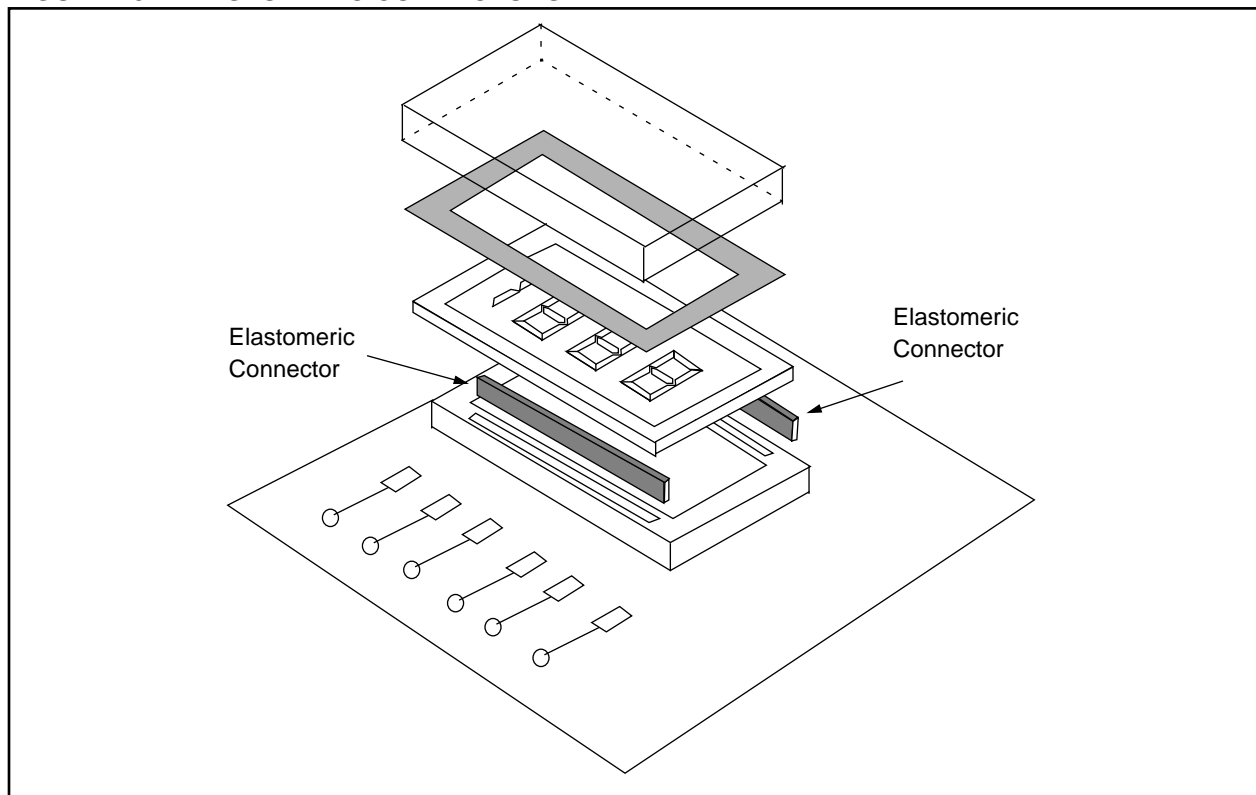

AN658

One of the newer methods is the flex connector. A PCB and the LCD panel are connected by a flexible cable using a heat seal process. The flexible cable is typically an anisotropic connective film that is applied to the PCB and LCD panel using heat and pressure. These connectors were designed for harsh environments where the connector must be flexible enough to prevent breakage during stress. These connectors are becoming more popular with large or remotely mounted LCD panels. Figure 14 shows a typical application.

FIGURE 14: FLEX CONNECTORS

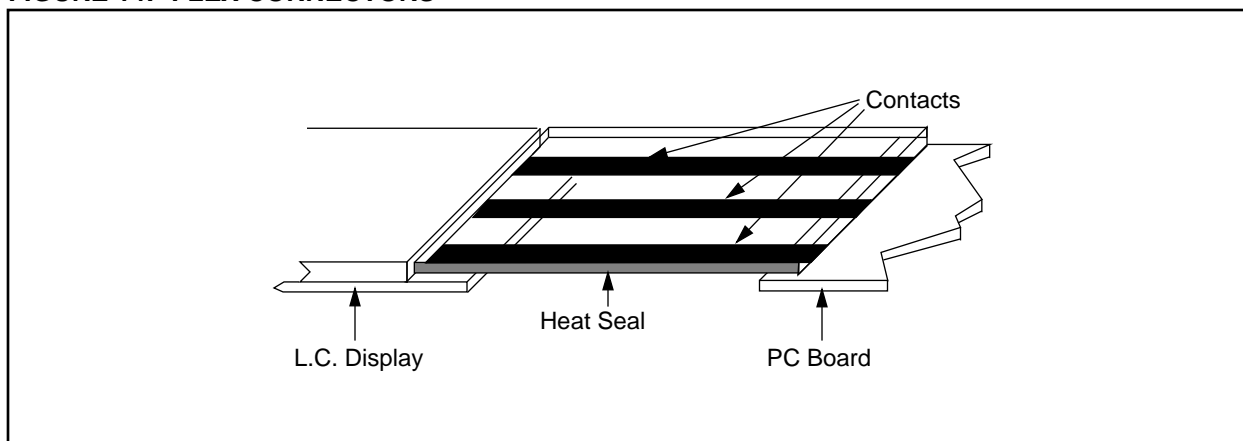

WHAT ARE THE DIFFERENT TYPES OF LCD PANELS?

LCD panels come in many flavors depending on the application and the operating environment. LCDs can be classified in two ways. First of all, LCDs come in direct drive or multiplex drive variations. Direct drive, otherwise known as static, means that each pixel of the LCD panel has an independent driver. The LCD panel also has only one backplane. A static drive panel also has static bias. Bias is defined as the number of voltage levels the LCD driver uses to create images on the screen. The number of voltage levels is equivalent to the $1 + 1/\text{bias}$. Static bias refers to two voltage levels which create a square wave, ground and V_{DD} . Static drive panels also have the best contrast ratios over the widest temperature range.

Multiplex drive panels reduce the overall amount of interconnections between the LCD and the driver. Put simply, multiplex panels have more than one backplane. A multiplex LCD driver produces an amplitude-varying, time synchronized waveform for both the segment and backplanes. These waveforms allow access to one pixel on each of the backplanes. This significantly increases the complexity of the driver. The number of backplanes a panel has is referred to the multiplexing ratio or "MUX" of the panel. MUX also refers to duty cycle. For instance, a $1/3$ MUX panel has three backplanes. The bias for multiplex panels is at least $1/2 - 1/5$ for segment type drivers and from $1/8 - 1/33$ for dot matrix. Table 3 illustrates the advantage of multiplex panels.

TABLE 3: STATIC vs. MULTIPLEX PIN COUNT

LCD panel	Back planes	Segments	Total
3 - 1/2 digit	1	23	24
	2	12	14
8 digits	1	64	65
	4	16	20
2 x 16 character dot matrix, 5 x 7 characters	1	1280	1281
	8	160	168
	16	80	96
128 x 240 graphic display	1	30,720	30721
	64	480	544
	128	240	368

The last time Microchip investigated high pin count packages, 30,000+ was not an option.

PIC16C92X microcontrollers have the following drive capabilities:

TABLE 4: PIC16C92X DRIVE CAPABILITY

MUX	Bias	Backplanes	Segments
Static	Static	1	32
1/2	1/3	2	31
1/3	1/3	3	30
1/4	1/3	4	29

The other method of classifying LCD panels is the type of display notation used, i.e. segment, dot matrix, or functional. Segment displays are usually the 7-segment, 14-segment, or 16-segment ("British Flag") types used to create numbers and letters. These type of displays are static drive which provides the best contrast and readability in sunlight. Figure 15 shows all three segment displays mentioned.

FIGURE 15: SEGMENT TYPE DISPLAY

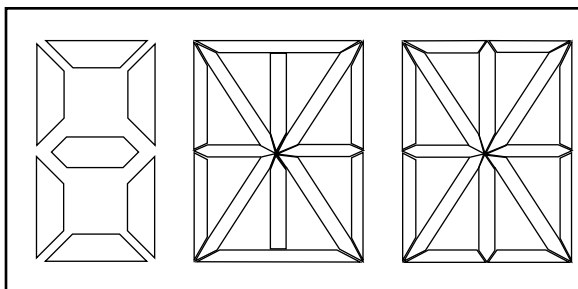

Dot matrix displays are always multiplex type displays due to the large number of pixels required and pin limitations on the driver. Dot matrix displays can create more natural letters and numbers as well as custom graphic symbols. Figure 16 shows a typical 5x7 dot matrix character set.

The third type of display is most commonly used in conjunction with the previous types. A function indicator or icon provides status information about the system. They are only capable of being turned on or off. One example would be a digital multimeter. The meter has three 1/2 digits which are 7-segment type and also some icons for volts, amps, ohms and the ranges for m, μ , K, and M. Another example would be a cellular telephone. The LCD panel will have eight or more 5x7 dot matrix characters with icons for events such as in use, roam, no service, battery status, and signal strength. Figure 17 shows what a typical cellular phone panel might resemble.

FIGURE 16: 5x7 DOT MATRIX DISPLAY

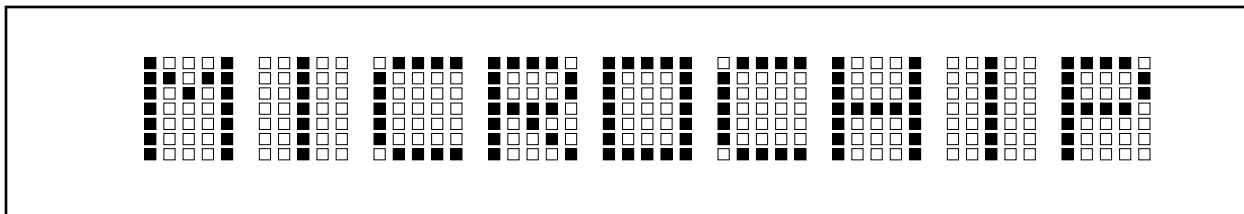
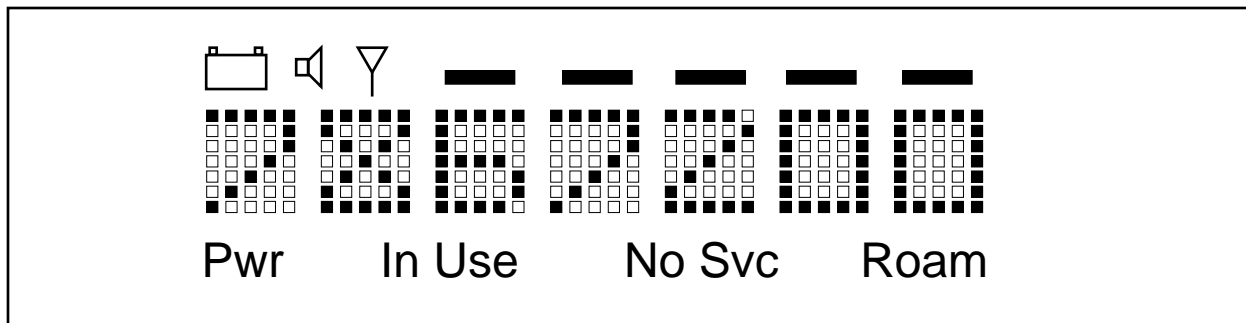

FIGURE 17: TYPICAL CELLULAR PHONE PANEL



AN658

HOW ARE LCD PANELS DRIVEN?

So far, the mysteries of how an LCD is made, how it works, and what the different type of panels have been revealed. This section will demystify the LCD waveforms. An LCD can be characterized by the MUX ratio and bias, but one piece of information is still missing - Drive Waveforms. LCDs can be driven by two types of waveforms: Type A and Type B. Before the definitions of the two types are given, the term frame frequency must be defined. The LCD frame frequency is the rate at which the backplane and segment outputs change. The frame frequency is then calculated to be the LCD period / $2 \cdot$ number of backplanes. The range of frame frequencies is from 25 to 250 Hz with the most common being between 50 and 150 Hz. Higher frequencies result in higher power consumption while lower frequencies cause flicker in the images on the LCD panel. An earlier section mentioned that a LCD

driver must maintain a 0 Vdc potential across each pixel. Type A waveforms maintain 0 Vdc over a single frame whereas Type B takes two frames. Figure 18 shows both types of waveforms with 1/3 MUX and 1/3 Bias. PIC16C92X microcontrollers support only Type A waveforms.

The voltage applied across a particular pixel is the voltage on the COM pin minus the voltage on the SEG pin. If the resulting voltage is at or above the V_{ON} threshold then the pixel is visible. Otherwise the voltage will be at or below the V_{OFF} threshold and the pixel will not be visible. This formula is used for all drive/bias methods. The following figures show each of the modes that are currently supported by the PIC16C92X devices. Since the PIC16C92X devices only support Type A waveforms, only Type A waveforms for each of the modes are shown. Each figure has the LCD period and the frame locations marked.

FIGURE 18: TYPE A vs. TYPE B WAVEFORMS

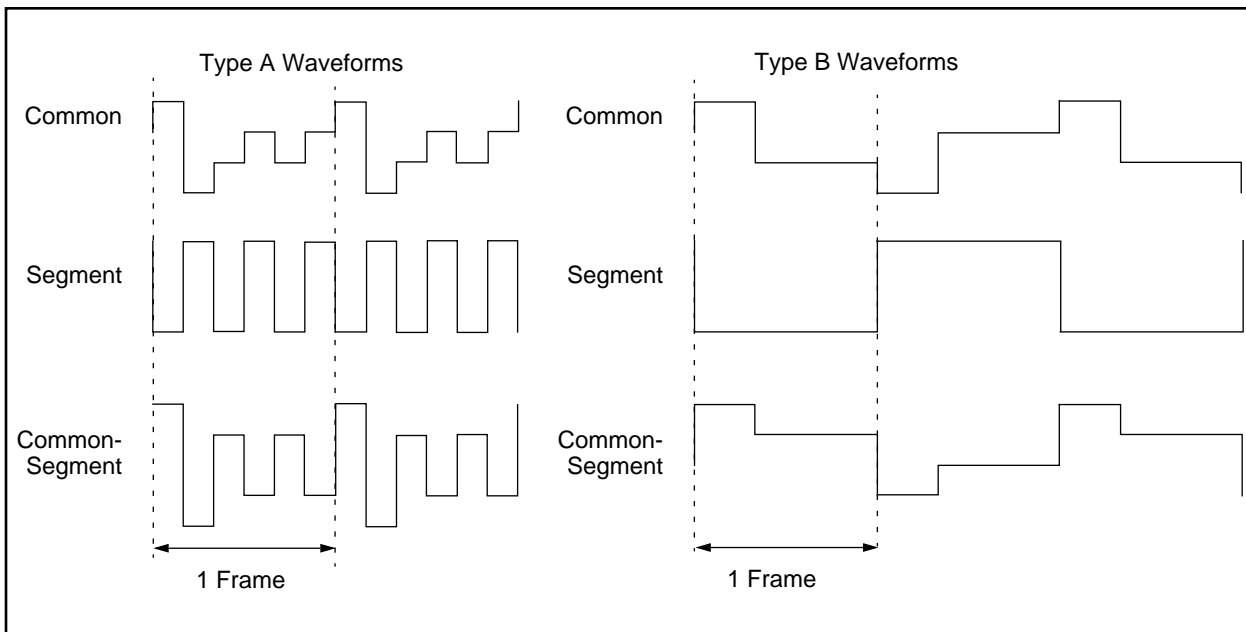
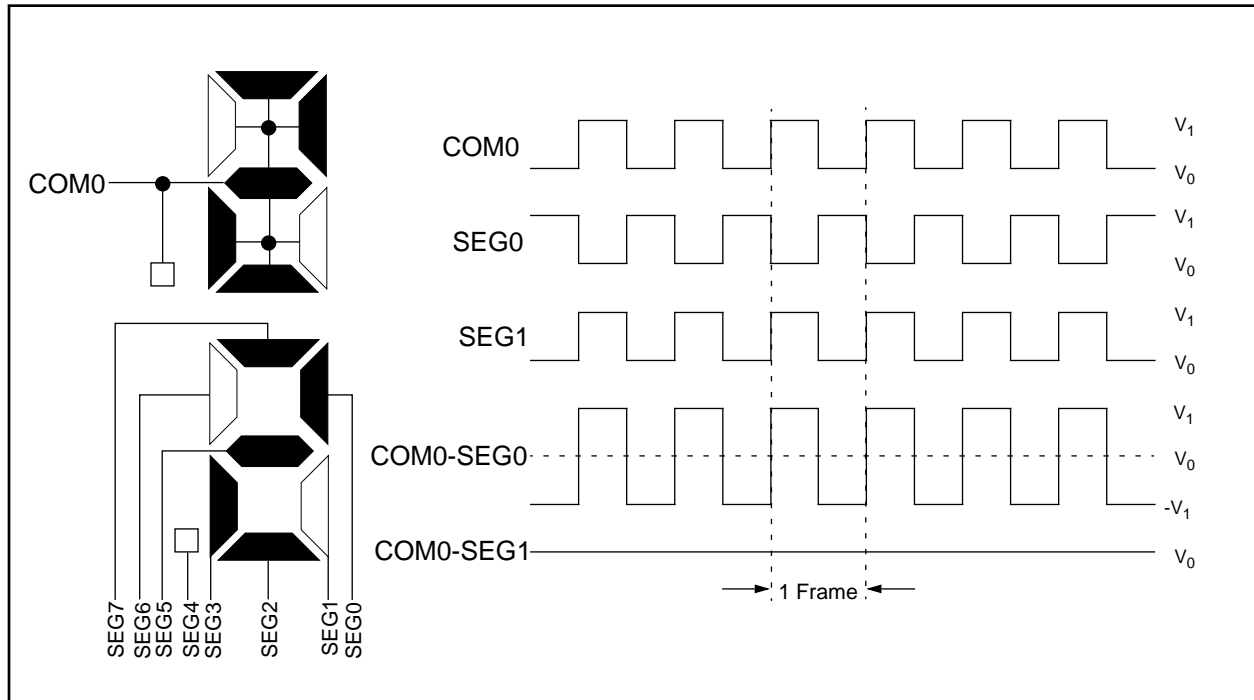

FIGURE 19: STATIC WAVEFORMS



AN658

FIGURE 20: 1/2 MUX, 1/3 BIAS WAVEFORM

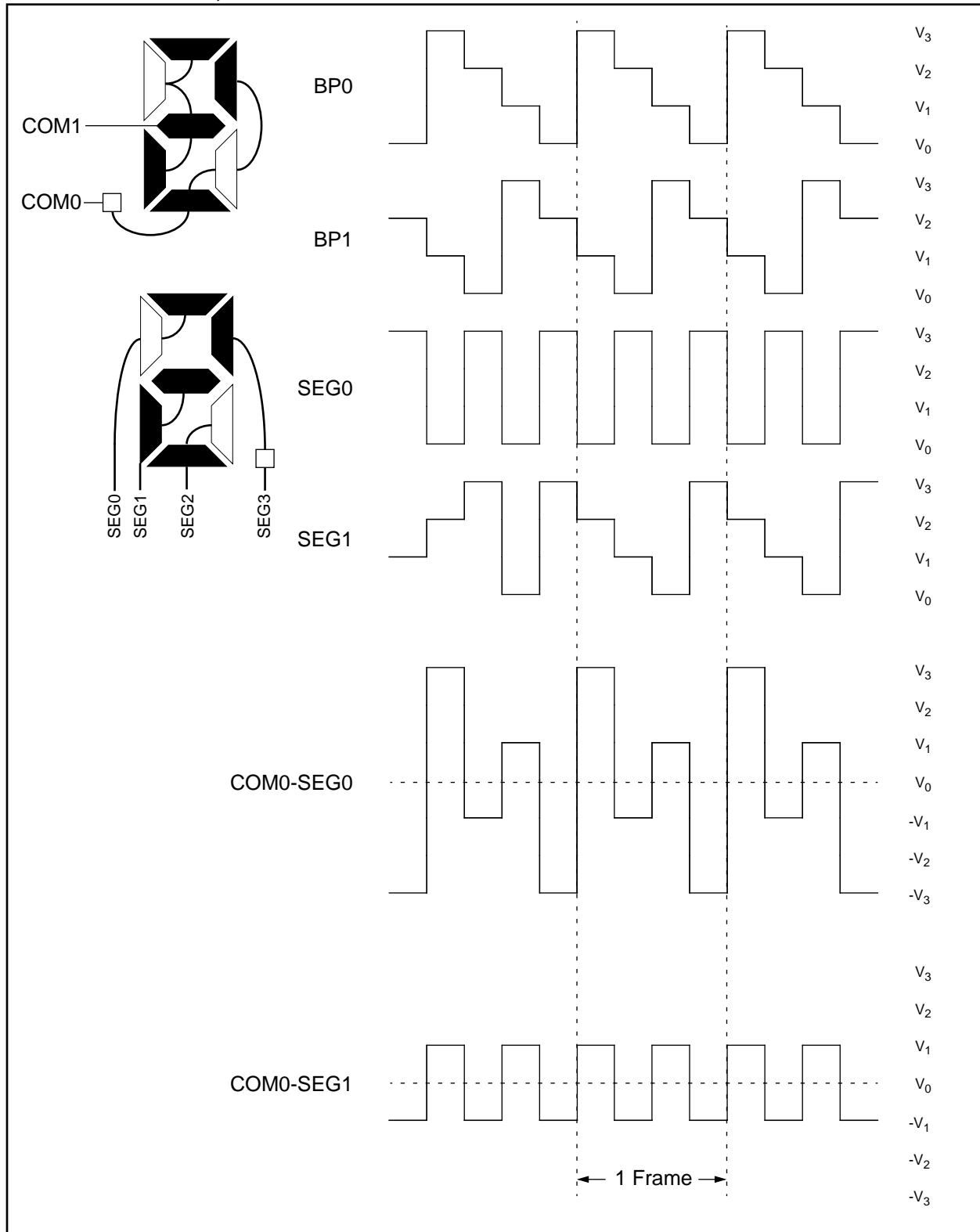
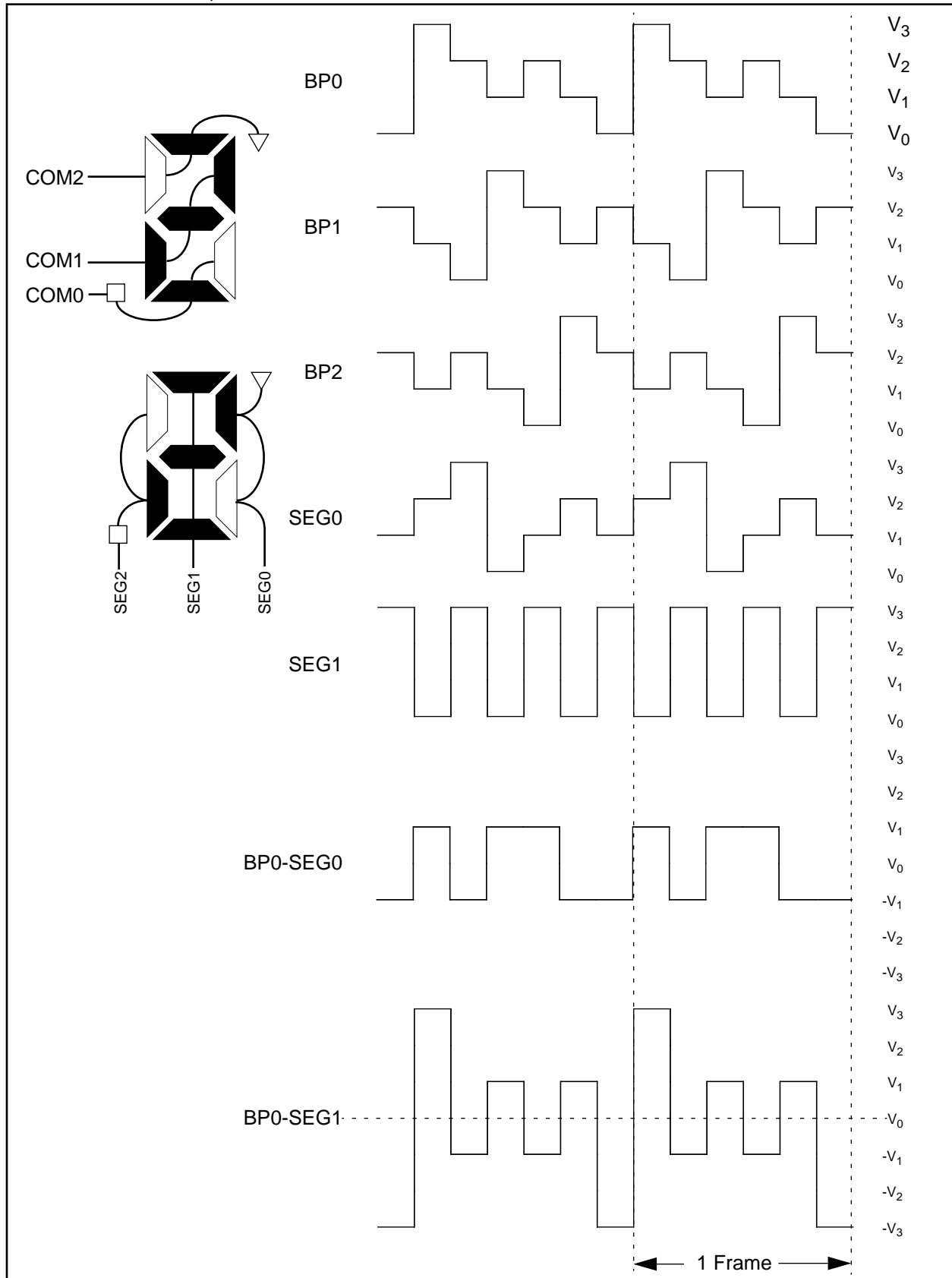
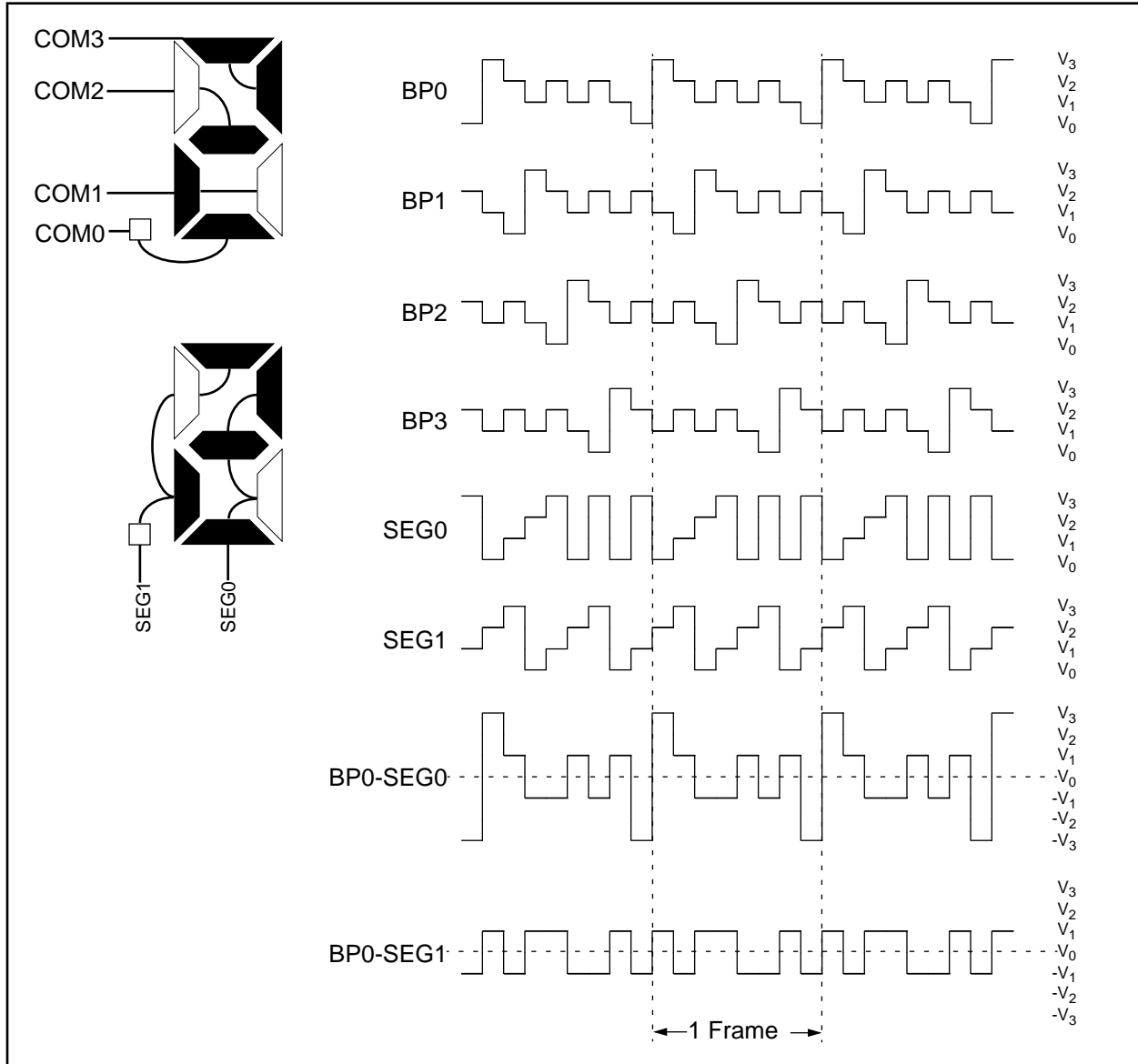

FIGURE 21: 1/3 MUX, 1/3 BIAS WAVEFORM



AN658

FIGURE 22: 1/4 MUX, 1/3 BIAS WAVEFORM



DISCRIMINATION RATIO

Now that the LCD waveforms have been presented, let's calculate the discrimination ratio for some of them. The first example is a static waveform from Figure 19. The voltages V_1 and V_0 will be assigned values of 1

and 0. The next step is to construct a matrix for one frame to help visualize the DC and RMS voltages present on an individual pixel when it is ON and when it is OFF. The rest of the following shows the calculation of the DC, RMS, and Discrimination Ratio.

EXAMPLE 1: DISCRIMINATION RATIO CALCULATION FOR STATIC MUX

BPx	0	1	
SEGx	1	0	ON
	0	1	OFF

$$\text{BPx} - \text{SEGx} [\text{ON}] = -1 + 1, \quad V_{\text{DC}} = 0$$

$$\text{BPx} - \text{SEGx} [\text{OFF}] = 0 + 0, \quad V_{\text{DC}} = 0$$

$$V_{\text{RMS}} [\text{ON}] = \Delta V \sqrt{\frac{(-1)^2 + (1)^2}{2}} = 1\Delta V$$

$$V_{\text{RMS}} [\text{OFF}] = \Delta V \sqrt{\frac{(0)^2 + (0)^2}{2}} = 0\Delta V$$

$$D = \frac{V_{\text{RMS}} [\text{ON}]}{V_{\text{RMS}} [\text{OFF}]} = \frac{1\Delta V}{0\Delta V} = \infty$$

The next example is for Figure 22 which is a 1/4 MUX, 1/3 BIAS waveform. For this example, the values 3, 2, 1 and 0 will be assigned to V_3 , V_2 , V_1 , and V_0 respectively. The frame matrix, DC voltage, RMS voltage and discrimination ratio calculations are shown in Example 2:

EXAMPLE 2: DISCRIMINATION RATIO CALCULATION 1/4 MUX

BP0	0	3	2	1	2	1	2	1	
BP1	2	1	0	3	2	1	2	1	
BP2	2	1	2	1	0	3	2	1	
BP3	2	1	2	1	2	1	0	3	
SEGx	3	0	3	0	3	0	3	0	ON
	1	2	1	2	1	2	1	2	OFF

$$\begin{aligned} \text{BP0} - \text{SEGx} [\text{ON}] &= -3 + 3 - 1 + 1 - 1 + 1 - 1 + 1 & V_{\text{DC}} &= 0 \\ \text{BP0} - \text{SEGx} [\text{OFF}] &= -1 + 1 - 1 + 1 - 1 + 1 - 1 + 1 & V_{\text{DC}} &= 0 \end{aligned}$$

$$V_{\text{RMS}} [\text{ON}] = \Delta V \sqrt{\frac{(-3)^2 + (3)^2 + (-1)^2 + (1)^2 + (-1)^2 + (1)^2 + (-1)^2 + (1)^2}{8}} = \sqrt{3} \Delta V$$

$$V_{\text{RMS}} [\text{OFF}] = \Delta V \sqrt{\frac{(-1)^2 + (1)^2 + (-1)^2 + (1)^2 + (-1)^2 + (1)^2 + (-1)^2 + (1)^2}{8}} = \Delta V$$

$$D = \frac{V_{\text{RMS}} [\text{ON}]}{V_{\text{RMS}} [\text{OFF}]} = \frac{\sqrt{3} \Delta V}{1 \Delta V} = 1.732$$

AN658

As shown in these examples, static displays have excellent contrast. The higher the multiplex ratio of the LCD, the lower the discrimination ratio, and therefore, the lower the contrast of the display.

The following table shows the V_{OFF} , V_{ON} and discrimination ratios of the various combinations of MUX and BIAS.

TABLE 5: DISCRIMINATION RATION vs. MUX AND BIAS

	1/3 BIAS		
	Voff	Von	D
STATIC	0	1	∞
1/2 MUX	0.333	0.745	2.236
1/3 MUX	0.333	0.638	1.915
1/4 MUX	0.333	0.577	1.732

Table 5 shows that as the multiplex of the LCD panel increases, the discrimination ratio decreases. The contrast of the panel will also decrease, so to provide better contrast the LCD voltages must be increased to provide greater separation between each level.

LCD VOLTAGE GENERATION

Among the many ways to generate LCD voltage, two methods stand out above the crowd: resistor ladder and charge pump.

FIGURE 23: RESISTOR LADDER

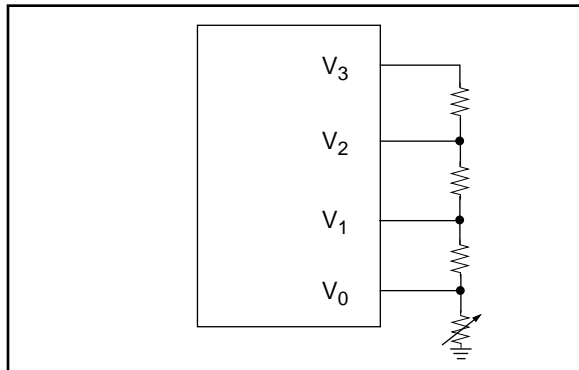

The resistor ladder methods, shown in Figure 23 is most commonly used for higher V_{CC} voltages. This method uses inexpensive resistors to create the multi-level LCD voltages. Regardless of the number of pixels that are energized the current remains constant. The voltage at point V_3 is typically tied to V_{CC} , either internally or externally.

The resistance values are determined by two factors: display quality and power consumption. Display quality is a function of the LCD drive waveforms. Since the

LCD panel is a capacitive load, the waveform is distorted due to the charging and discharging currents. This distortion can be reduced by decreasing the value of resistance. However this change increases the power consumption due to the increased current now flowing through the resistors. As the LCD panel increases in size, the resistance value must be decreased to maintain the image quality of the display.

Sometimes the addition of parallel capacitors to the resistance can reduce the distortion caused by charging/discharging currents. This effect is limited since at some point a large resistor and large capacitor cause a voltage level shift which negatively impacts the display quality. In general, R is $1\text{ k}\Omega$ to $50\text{ k}\Omega$ and the potentiometer is $5\text{ k}\Omega$ to $200\text{ k}\Omega$.

FIGURE 24: RESISTOR LADDER WITH CAPACITORS

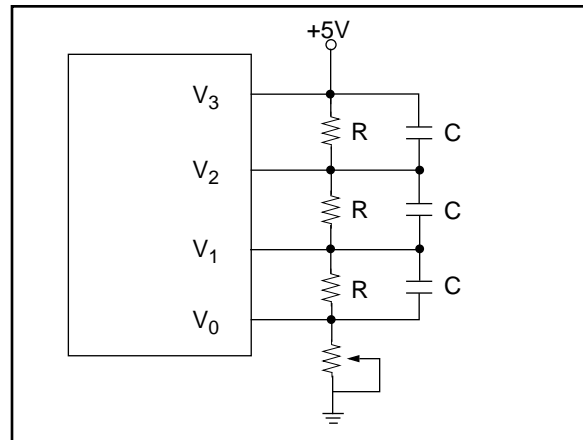

A charge pump is ideal for low voltage battery operation because the V_{DD} voltage can be boosted up to drive the LCD panel. The charge pump requires a charging capacitor and filter capacitor for each of the LCD voltages as seen in Figure 25. These capacitors are typically polyester, polypropylene, or polystyrene material. Another feature that makes the charge pump ideal for battery applications is that the current consumption is proportional to the number of pixels that are energized.

FIGURE 25: CHARGE PUMP

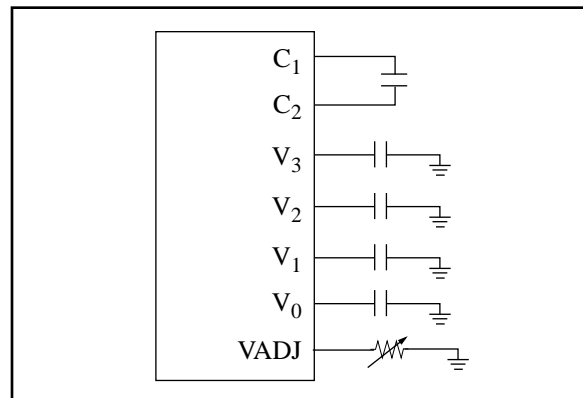

CONTRAST

Although contrast is heavily dependent on the light source available and the multiplex mode, it also varies with the LCD voltage levels. As previously seen, a potentiometer is used to control the contrast of the LCD panel. The potentiometer sets the separation between each of the LCD voltages. The larger the separation, the better the contrast achievable.

CONCLUSION:

Hopefully you can now answer the questions:

- What are the basic components in an LCD panel?
- How does an LCD work?
- What are the different types of LCD panels?
- How are LCD panels driven?

This application note has covered LCD fundamentals in great detail. Please refer to the PIC16C92X microcontroller data sheet for more information. Also application note AN649, "Yet Another Clock Featuring the PIC16C924" shows an example application using the PIC16C924.

APPENDIX A: LIST OF LCD MANUFACTURERS AND DISTRIBUTORS

AEG-MIS
3340 Peachtree Rd. NE Suite 500
Atlanta, GA 30326
TEL: 404-239-0277
FAX: 404-239-0383

All Shore INDS Inc.
1 Edgewater Plaza
Staten Island, NY 10305
TEL: 718-720-0018
FAX: 718-720-0225

Crystaloid
5282 Hudson Drive
Hudson, OH 44236-3769
TEL: 216-655-2429
FAX: 216-655-2176

DCI Inc.
14812 W. 117th St.
Olathe, KS 66062-9304
TEL: 913-782-5672
FAX: 913-782-5766

Excel Technology International Corporation
Unit 5, Bldg. 4, Stryker Lane
Belle Mead, NJ 08502
TEL: 908-874-4747
FAX: 908-874-3278

F-P Electronics/Mark IV Industries
6030 Ambler Drive
Mississauga, ON Canada L4W 2P1
TEL: 905-624-3020
FAX: 905-238-3141

Hunter Components
24800 Chagrin Blvd, Suite 101
Cleveland, OH 44122
TEL: 216-831-1464
FAX: 216-831-1463

Satori Electric
23717 Hawthorne Blvd. 3rd Floor
Torrance, CA 90505
TEL: 310-214-1791
FAX: 310-214-1721

Interstate Electronics Corp.
1001 E. Bull Rd.
Anaheim, CA 92805
TEL: 800-854-6979
FAX: 714-758-4111

Kent Display Systems
343 Portage Blvd.
Kent, OH 44240
TEL: 330-673-8784

LCD Planar Optics Corporation
2100-2 Artic Ave.
Bohemia, NY 11716
TEL: 516-567-4100
FAX: 516-567-8516

LXD Inc.
7650 First Place
Oakwood Village, OH 44146
TEL: 216-786-8700
FAX: 216-786-8711

Nippon Sheet Glass
Tomen America Inc.
1285 Avenue of the Americas
New York, NY 10019
TEL: 212-397-4600
FAX: 212-397-3351

OPTREX America
44160 Plymouth Oaks Blvd.
Plymouth, MI 48170
TEL: 313-416-8500
FAX: 313-416-8520

Phillips Components
LCD Business Unit
1273 Lyons Road, Bldg G
Dayton, OH 45459
TEL: 573-436-9500
FAX: 573-436-2230

Varitronix Limited Inc.
3250 Wilshire Blvd. Suite 1901
Los Angeles, CA 90010
TEL: 213-738-8700
FAX: 213-738-5340

Seiko Instruments USA Inc.
Electronic Components Division
2990 West Lomita Blvd.
Torrance, CA 90505
TEL: 213-517-7770
213-517-8113
FAX: 213-517-7792

Standish International
European Technical Center
Am Baumstuck II
65520 Bad Camberg/Erbach
Germany
TEL: 011 49 6434 3324
FAX: 011 49 6434 377238

Standish LCD
W7514 Highway V
Lake Mills, WI 53551
TEL: 414-648-1000
FAX: 414-648-1001

Truly Semiconductors Ltd. (USA)
2620 Concord Ave.
Suite 106
Alhambra, CA 91803
TEL: 818-284-3033
FAX: 818-284-6026

Truly Semiconductor Ltd.
2/F, Chung Shun Knitting Center
1-3 Wing Yip Street,
Kwai Chung, N.T., Hong Kong
TEL: 852 2487 9803
FAX: 852 2480 0126

Varitronix Limited Inc.
4/F, Liven House
61-63 King Yip Street
Kwun Tong, Kowloon
Hong Kong
TEL: 852 2389 4317
FAX: 852 2343 9555

Varitronix (France) S.A.R.L.
13/15 Chemin De Chilly
91160 Champlan
France
TEL: (33) 1 69 09 7070
FAX: (33) 1 69 09 0535

Varitronix Italia, S.R.L.
Via Bruno Buozzi 90
20099 Sesto San Giovanni
Milano, Italy
TEL: (39) 2 2622 2744
FAX: (39) 2 2622 2745

Varitronix (UK) Limited
Display House, 3 Milbanke Court
Milbanke Way, Bracknell
Berkshire RG12 1BR
United Kingdom
TEL: (44) 1344 30377
FAX (44) 1344 300099

Varitronix (Canada) Limited
18 Crown Steel Drive, Suite 101
Markham, Ontario
Canada L3R 9X8
TEL: (905) 415-0023
FAX: (905) 415-0094

Vikay America Inc.
195 W. Main St.
Avon, CT 06001-3685
TEL: 860-678-7600
FAX: 860-678-7625

AN658

DISTRIBUTORS

Allied Electronics Inc.
7410 Pebble Drive
Fort Worth, TX 76118
TEL: 800-433-5700
<http://www.allied.avnet.com>

Digikey Corporation
701 Brooks Ave. South
Thief River Falls, MN 56701-0677
TEL: 800-344-4539
<http://www.digikey.com>

Newark Electronics
Administrative Office
4801 N. Ravenswood Ave.
Chicago, IL 60640-4496
TEL: 312-784-5700
FAX: 312-907-5217

Note the following details of the code protection feature on PICmicro® MCUs.

- The PICmicro family meets the specifications contained in the Microchip Data Sheet.
- Microchip believes that its family of PICmicro microcontrollers is one of the most secure products of its kind on the market today, when used in the intended manner and under normal conditions.
- There are dishonest and possibly illegal methods used to breach the code protection feature. All of these methods, to our knowledge, require using the PICmicro microcontroller in a manner outside the operating specifications contained in the data sheet. The person doing so may be engaged in theft of intellectual property.
- Microchip is willing to work with the customer who is concerned about the integrity of their code.
- Neither Microchip nor any other semiconductor manufacturer can guarantee the security of their code. Code protection does not mean that we are guaranteeing the product as “unbreakable”.
- Code protection is constantly evolving. We at Microchip are committed to continuously improving the code protection features of our product.

If you have any further questions about this matter, please contact the local sales office nearest to you.

Information contained in this publication regarding device applications and the like is intended through suggestion only and may be superseded by updates. It is your responsibility to ensure that your application meets with your specifications. No representation or warranty is given and no liability is assumed by Microchip Technology Incorporated with respect to the accuracy or use of such information, or infringement of patents or other intellectual property rights arising from such use or otherwise. Use of Microchip's products as critical components in life support systems is not authorized except with express written approval by Microchip. No licenses are conveyed, implicitly or otherwise, under any intellectual property rights.

Trademarks

The Microchip name and logo, the Microchip logo, FilterLab, KEELOQ, microID, MPLAB, PIC, PICmicro, PICMASTER, PICSTART, PRO MATE, SEEVAL and The Embedded Control Solutions Company are registered trademarks of Microchip Technology Incorporated in the U.S.A. and other countries.

dsPIC, ECONOMONITOR, FanSense, FlexROM, fuzzyLAB, In-Circuit Serial Programming, ICSP, ICEPIC, microPort, Migratable Memory, MPASM, MPLIB, MPLINK, MPSIM, MXDEV, PICC, PICDEM, PICDEM.net, rPIC, Select Mode and Total Endurance are trademarks of Microchip Technology Incorporated in the U.S.A.

Serialized Quick Turn Programming (SQTP) is a service mark of Microchip Technology Incorporated in the U.S.A.

All other trademarks mentioned herein are property of their respective companies.

© 2002, Microchip Technology Incorporated, Printed in the U.S.A., All Rights Reserved.

 Printed on recycled paper.

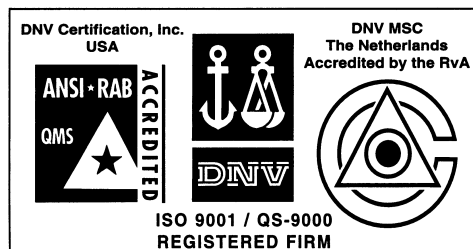

Microchip received QS-9000 quality system certification for its worldwide headquarters, design and wafer fabrication facilities in Chandler and Tempe, Arizona in July 1999. The Company's quality system processes and procedures are QS-9000 compliant for its PICmicro® 8-bit MCUs, KEELOQ® code hopping devices, Serial EEPROMs and microperipheral products. In addition, Microchip's quality system for the design and manufacture of development systems is ISO 9001 certified.



MICROCHIP

WORLDWIDE SALES AND SERVICE

AMERICAS

Corporate Office

2355 West Chandler Blvd.
Chandler, AZ 85224-6199
Tel: 480-792-7200 Fax: 480-792-7277
Technical Support: 480-792-7627
Web Address: <http://www.microchip.com>

Rocky Mountain

2355 West Chandler Blvd.
Chandler, AZ 85224-6199
Tel: 480-792-7966 Fax: 480-792-7456

Atlanta

500 Sugar Mill Road, Suite 200B
Atlanta, GA 30350
Tel: 770-640-0034 Fax: 770-640-0307

Boston

2 Lan Drive, Suite 120
Westford, MA 01886
Tel: 978-692-3848 Fax: 978-692-3821

Chicago

333 Pierce Road, Suite 180
Itasca, IL 60143
Tel: 630-285-0071 Fax: 630-285-0075

Dallas

4570 Westgrove Drive, Suite 160
Addison, TX 75001
Tel: 972-818-7423 Fax: 972-818-2924

Detroit

Tri-Atria Office Building
32255 Northwestern Highway, Suite 190
Farmington Hills, MI 48334
Tel: 248-538-2250 Fax: 248-538-2260

Kokomo

2767 S. Albright Road
Kokomo, Indiana 46902
Tel: 765-864-8360 Fax: 765-864-8387

Los Angeles

18201 Von Karman, Suite 1090
Irvine, CA 92612
Tel: 949-263-1888 Fax: 949-263-1338

New York

150 Motor Parkway, Suite 202
Hauppauge, NY 11788
Tel: 631-273-5305 Fax: 631-273-5335

San Jose

Microchip Technology Inc.
2107 North First Street, Suite 590
San Jose, CA 95131
Tel: 408-436-7950 Fax: 408-436-7955

Toronto

6285 Northam Drive, Suite 108
Mississauga, Ontario L4V 1X5, Canada
Tel: 905-673-0699 Fax: 905-673-6509

ASIA/PACIFIC

Australia

Microchip Technology Australia Pty Ltd
Suite 22, 41 Rawson Street
Epping 2121, NSW
Australia
Tel: 61-2-9868-6733 Fax: 61-2-9868-6755

China - Beijing

Microchip Technology Consulting (Shanghai)
Co., Ltd., Beijing Liaison Office
Unit 915
Bei Hai Wan Tai Bldg.
No. 6 Chaoyangmen Beidajie
Beijing, 100027, No. China
Tel: 86-10-85282100 Fax: 86-10-85282104

China - Chengdu

Microchip Technology Consulting (Shanghai)
Co., Ltd., Chengdu Liaison Office
Rm. 2401, 24th Floor,
Ming Xing Financial Tower
No. 88 TIDU Street
Chengdu 610016, China
Tel: 86-28-6766200 Fax: 86-28-6766599

China - Fuzhou

Microchip Technology Consulting (Shanghai)
Co., Ltd., Fuzhou Liaison Office
Unit 28F, World Trade Plaza
No. 71 Wusi Road
Fuzhou 350001, China
Tel: 86-591-7503506 Fax: 86-591-7503521

China - Shanghai

Microchip Technology Consulting (Shanghai)
Co., Ltd.
Room 701, Bldg. B
Far East International Plaza
No. 317 Xian Xia Road
Shanghai, 200051
Tel: 86-21-6275-5700 Fax: 86-21-6275-5060

China - Shenzhen

Microchip Technology Consulting (Shanghai)
Co., Ltd., Shenzhen Liaison Office
Rm. 1315, 13/F, Shenzhen Kerry Centre,
Renminnan Lu
Shenzhen 518001, China
Tel: 86-755-2350361 Fax: 86-755-2366086

Hong Kong

Microchip Technology Hongkong Ltd.
Unit 901-6, Tower 2, Metroplaza
223 Hing Fong Road
Kwai Fong, N.T., Hong Kong
Tel: 852-2401-1200 Fax: 852-2401-3431

India

Microchip Technology Inc.
India Liaison Office
Divyasree Chambers
1 Floor, Wing A (A3/A4)
No. 11, O'Shaugnessey Road
Bangalore, 560 025, India
Tel: 91-80-2290061 Fax: 91-80-2290062

Japan

Microchip Technology Japan K.K.
Benex S-1 6F
3-18-20, Shinyokohama
Kohoku-Ku, Yokohama-shi
Kanagawa, 222-0033, Japan
Tel: 81-45-471- 6166 Fax: 81-45-471-6122

Korea

Microchip Technology Korea
168-1, Youngbo Bldg. 3 Floor
Samsung-Dong, Kangnam-Ku
Seoul, Korea 135-882
Tel: 82-2-554-7200 Fax: 82-2-558-5934

Singapore

Microchip Technology Singapore Pte Ltd.
200 Middle Road
#07-02 Prime Centre
Singapore, 188980
Tel: 65-334-8870 Fax: 65-334-8850

Taiwan

Microchip Technology Taiwan
11F-3, No. 207
Tung Hua North Road
Taipei, 105, Taiwan
Tel: 886-2-2717-7175 Fax: 886-2-2545-0139

EUROPE

Denmark

Microchip Technology Nordic ApS
Regus Business Centre
Lautrup høj 1-3
Ballerup DK-2750 Denmark
Tel: 45 4420 9895 Fax: 45 4420 9910

France

Microchip Technology SARL
Parc d'Activite du Moulin de Massy
43 Rue du Saule Trapu
Batiment A - ler Etage
91300 Massy, France
Tel: 33-1-69-53-63-20 Fax: 33-1-69-30-90-79

Germany

Microchip Technology GmbH
Gustav-Heinemann Ring 125
D-81739 Munich, Germany
Tel: 49-89-627-144 0 Fax: 49-89-627-144-44

Italy

Microchip Technology SRL
Centro Direzionale Colleoni
Palazzo Taurus 1 V. Le Colleoni 1
20041 Agrate Brianza
Milan, Italy
Tel: 39-039-65791-1 Fax: 39-039-6899883

United Kingdom

Arizona Microchip Technology Ltd.
505 Eskdale Road
Winnersh Triangle
Wokingham
Berkshire, England RG41 5TU
Tel: 44 118 921 5869 Fax: 44-118 921-5820

01/18/02