

Crystal Oscillator Basics and Crystal Selection for rPIC™ and PICmicro® Devices

Author: Steven Bible
Microchip Technology Inc.

INTRODUCTION

Oscillators are an important component of radio frequency (RF) and digital devices. Today, product design engineers often do not find themselves designing oscillators because the oscillator circuitry is provided on the device. However, the circuitry is not complete. Selection of the crystal and external capacitors have been left to the product design engineer. If the incorrect crystal and external capacitors are selected, it can lead to a product that does not operate properly, fails prematurely, or will not operate over the intended temperature range. For product success it is important that the designer understand how an oscillator operates in order to select the correct crystal.

Selection of a crystal appears deceptively simple. Take for example the case of a microcontroller. The first step is to determine the frequency of operation which is typically one of several standard values that can be selected from a catalog, distributor, or crystal manufacturer. The second step is to sample or purchase the crystal and evaluate it in the product design.

However, in radio frequency (RF) circuitry, the selection of the crystal is not as simple. For example, if a designer requires a transmit frequency ($f_{transmit}$) of 318 MHz for the rPIC12C509AG, the crystal frequency (f_{xtal}) will equal:

$$\begin{aligned} f_{xtal} &= \frac{f_{transmit}}{32} \\ &= \frac{318,000,000}{32} \\ &= 9,937,500 \text{ Hz} \end{aligned}$$

The frequency 9.9375 MHz is not a standard crystal frequency. Therefore, the designer must order a custom crystal from a crystal manufacturer. When the designer contacts the crystal manufacturer, he or she is asked a series of crystal specification questions that may be unfamiliar, such as:

- What crystal frequency do you require?
- Which mode of operation?
- Series or parallel resonant?
- What frequency tolerance do you desire?

- What temperature stability is needed?
- What temperature range will be required?
- Which enclosure (holder) do you desire?
- What load capacitance (C_L) do you require?
- What shunt capacitance (C_0) do you require?
- Is pullability required?
- What motional capacitance (C_1) do you require?
- What Equivalent Series Resistance (ESR) is required?
- What drive level is required?

To the uninitiated, these are overwhelming questions. What effect do these specifications have on the operation of the oscillator? What do they mean? It becomes apparent to the product design engineer that the only way to answer these questions is to understand how an oscillator works.

This Application Note will not make you into an oscillator designer. It will only explain the operation of an oscillator in simplified terms in an effort to convey the concepts that make an oscillator work.

The goal of this Application Note is to assist the product design engineer in selecting the correct crystal and external capacitors required for the rPIC™ or PICmicro® device. In order to do this the designer needs a clear understanding of the interrelationship of the various circuits that make up an oscillator circuit. The product design engineer should also consult with the crystal manufacturer about the needs of their product design.

OSCILLATOR MODELS

There are several methods to modeling oscillator behavior. One form is known as the one port view or negative resistance model. It predicts the behavior of the oscillator as an active network generating an impedance equal to a negative real resistance so that the equivalent parallel resistance seen by the intrinsic, lossless tuned circuit is infinite [1]. A second form is known as the two port view or feedback model consisting of an amplifier with gain G and a frequency selective filter element with a linear transfer function in the positive feedback path. This Application Note will use simplified forms of each view to explain the basic operations of an oscillator. A more detailed explanation of oscillator modeling and operation are available in the cited references.

OSCILLATOR BASICS

Reduced to its simplest components, the oscillator consists of an amplifier and a filter operating in a positive feedback loop (see Figure 1). The circuit must satisfy the Barkhausen criteria in order to begin oscillation:

- the loop gain exceeds unity at the resonant frequency, and
- phase shift around the loop is $n2\pi$ radians (where n is an integer)

The amplitude of the signal will grow once oscillation has started. The amplitude of the signal must be limited at some point and the loop gain equal unity. It is at this point the oscillator enters steady-state operation.

FIGURE 1: SIMPLIFIED OSCILLATOR BLOCK DIAGRAM

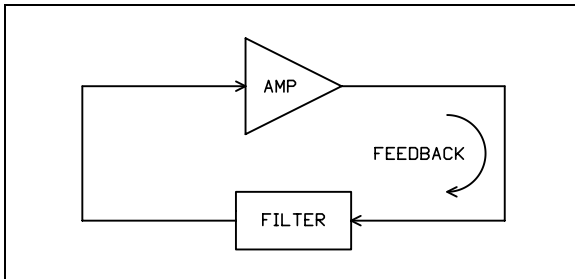

Looking at Figure 1, intuitively we see that the amplifier provides the gain for the first criteria. For the second criteria, phase shift, the amplifier is an inverting amplifier which causes a π radian (180 degree) phase shift. The filter block provides an additional π radian (180 degree) phase shift for a total of 2π radians (360 degrees) around the entire loop.

By design, the filter block inherently provides the phase shift in addition to providing a coupling network to and from the amplifier (see Figure 2). The filter block also sets the frequency that the oscillator will operate. This is done using a tuned circuit (inductor and capacitor) or crystal. The coupling network provides light loading so as to not overdrive the tuned circuit [2].

FIGURE 2: SIMPLIFIED OSCILLATOR BLOCK DIAGRAM WITH COUPLING NETWORK

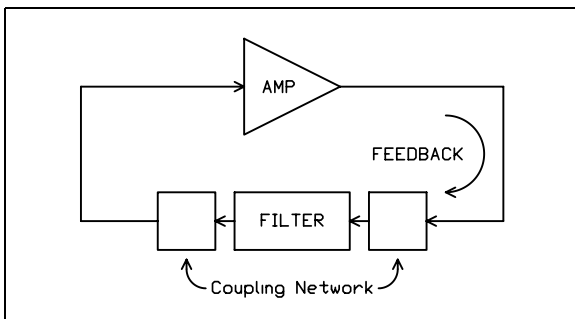

Oscillator Operation

Operation of an oscillator is generally broken up into two phases: start-up and steady-state operation. An oscillator must start by itself with no external stimulus. When the power is first applied, voltage changes in the bias network result in voltage changes in the filter network. These voltage changes excite the natural frequency of the filter network and signal buildup begins. The signal developed in the filter network is small. Positive feedback and excess gain in the amplifier continuously increases the signal until the non-linearity of the amplifier limits the loop gain to unity. At this point the oscillator enters steady-state operation. The time from power on to steady-state operation is the oscillator **start-up time**.

Steady-state operation of the oscillator is governed by the amplifier and the tuned circuit of the filter block. Loop gain steadies at unity due to the non-linearity of the amplifier. The tuned circuit reactance will adjust itself to match the Barkhausen phase requirement of 2π radians. During steady-state operation, we are concerned with the power output and loading of the tuned circuit.

Amplifier

The amplifier circuit is typically implemented with a bipolar junction transistor or field effect transistor (JFET, MOSFET, etc.). Linear characteristics of the transistor determine the starting conditions of the oscillator. Non-linear characteristics determine an oscillator operating point.

Tuned Circuits

The filter block sets the frequency that the oscillator will operate. This is done using an LC tuned circuit (inductor and capacitor) or crystal. Initially, we will look at a few basic oscillator circuits that use a LC tuned circuit. Later we will look at crystal basics and how crystal oscillators operate.

Figure 3 shows a basic LC series resonator using an inductor and capacitor. This is a simple band-pass filter that at resonance the capacitive reactance and inductive reactance are equal and cancel each other. There is a zero phase shift and only the real resistance remains.

FIGURE 3: BASIC LC SERIES RESONATOR

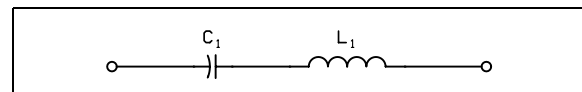

Since we are using an inverting amplifier, the filter block needs to provide a π radian (180 degree) phase shift in order to satisfy the second Barkhausen criteria. Figure 4 shows a four element shunt-C coupled LC series resonator that provides phase shift and a coupling network [3].

FIGURE 4: SHUNT-C COUPLED LC SERIES RESONATOR

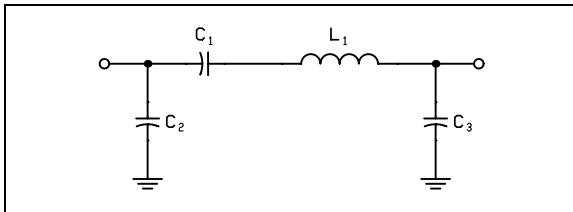

Quality Factor

Q (quality factor) is the ratio of stored energy in a reactive component such as a capacitor or inductor to the sum total of all energy losses. An ideal tuned circuit constructed of an inductor and capacitor will store energy by swapping current from one component to the next. In an actual tuned circuit, energy is lost through real resistance. The equation for a tuned circuit Q is reactance divided by resistance:

$$Q = \frac{X}{R}$$

We are concerned about circuit Q because it defines the bandwidth that a tuned circuit will operate. Bandwidth is defined as the frequency spread between the two frequencies at which the current amplitude decreases to 0.707 (1 divided by the square root of 2) times the maximum value. Since the power consumed by the real resistance, R , is proportionally to the square of the current, the power at these points is half of the maximum power at resonance [2]. These are called the half-power (-3dB) points.

For Q values of 10 or greater, the bandwidth can be calculated:

$$BW = \frac{f}{Q}$$

Where f is the resonant frequency of interest. Relatively speaking, a high- Q circuit has a much narrower bandwidth than a low- Q circuit. For oscillator operation, we are interested in the highest Q that can be obtained in the tuned circuit. However, there are external influences that effect circuit Q .

The Q of a tuned circuit is effected by external loads. Therefore we differentiate between unloaded and loaded Q . Unloaded Q defines a circuit that is not influenced by an external load. Loaded Q is a circuit influenced by load.

OSCILLATOR CIRCUITS

There are limitless circuit combinations that make up oscillators. Many of them take on the name of their inventors: Butler, Clapp, Colpitts, Hartley, Meacham, Miller, Seiler, and Pierce, just to name a few. Many of these circuits are derivatives of one another. The reader should not worry about a particular oscillator's nomenclature, but should focus on operating principles

[4]. No one circuit is universally suitable for all applications [5]. The choice of oscillator circuit depends on device requirements.

Now let's add circuitry to the simplified oscillator block diagram of Figure 2. Figure 5 shows a simplified oscillator circuit drawn with only the RF components, no biasing resistors, and no ground connection [3]. The inverting amplifier is implemented with a single transistor. The feedback mechanism depends upon which ground reference is chosen. Of the numerous oscillator types, there are three common ones: Pierce, Colpitts, and Clapp. Each consists of the same circuit except that the RF ground points are at different locations.

FIGURE 5: SIMPLIFIED OSCILLATOR CIRCUIT WITHOUT RF GROUND

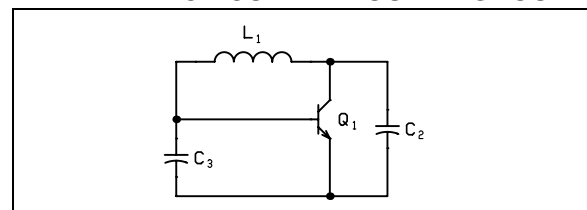

The type of oscillator that appears on the PICmicro[®] microcontroller is the Pierce and the type implemented on the rfPIC12C509AG/509AF transmitter is the Colpitts.

Pierce Oscillator

The Pierce oscillator (Figure 6) is a series resonant tuned circuit. Capacitors C2 and C3 are used to stabilize the amount of feedback preventing overdrive to the transistor amplifier.

The Pierce oscillator has many desirable characteristics. It will operate over a large range of frequencies and has very good short-term stability [6].

FIGURE 6: PIERCE OSCILLATOR

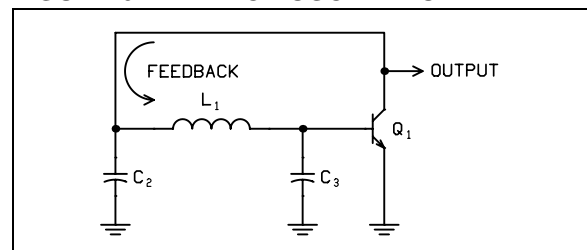

Colpitts Oscillator

The Colpitts oscillator (Figure 7) uses a parallel resonant tuned circuit. The amplifier is an emitter-follower. Feedback is provided via a tapped capacitor voltage divider (C2 and C3). Capacitors C2 and C3 form a capacitive voltage divider that couples some of the energy from the emitter to the base.

FIGURE 7: COLPITTS OSCILLATOR

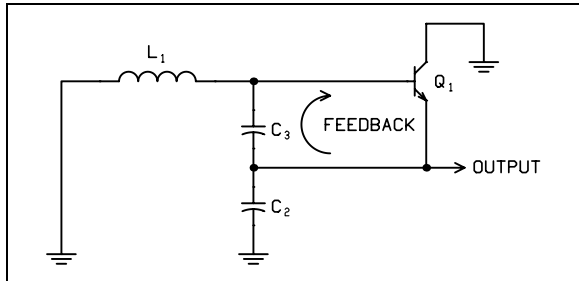

The Colpitts oscillator functions differently from the Pierce oscillator. The most important difference is in the biasing arrangement. Transistor biasing resistors can increase the effective resistance of the tuned circuit (LC or crystal) thus reducing its Q and decreasing the loop gain [5].

The parallel resonant circuit formed by L_1 in parallel with C_2 and C_3 determines the frequency of the oscillator.

CRYSTAL BASICS

The discussion up to this point has been on basic oscillators using inductors and capacitors for the tuned circuit. The main disadvantage of LC oscillators is that the frequency can drift due to changes in temperature, power-supply voltage, or mechanical vibrations. Placing a LC oscillator on frequency sometimes requires manual tuning.

We now look at how a quartz crystal operates internally and later we will see how they operate in crystal oscillators. Understanding how the quartz crystal operates will give the design engineer an understanding of how they behave in an oscillator circuit.

Quartz crystals have very desirable characteristics as oscillator tuned circuits. The natural oscillation frequency is very stable. In addition, the resonance has a very high Q ranging from 10,000 to several hundred thousand. In some cases values of 2 million are achievable. The crystal merits of high Q and stability are also its principle limitations. It is difficult to tune (*pull*) a crystal oscillator [3] (more on the topic of crystal pulling later).

The practical frequency range for Fundamental mode AT-cut crystals is 600 kHz to 30 MHz. Crystals for fundamental frequencies higher than 30 to 40 MHz are very thin and therefore fragile. Crystals are used at higher frequencies by operation at odd harmonics (overtones) of the fundamental frequency. Ninth overtone crystals are used up to about 200 MHz, the practical upper limit of crystal oscillators [3]. This Application Note will limit our discussion to Fundamental mode crystal operation.

Piezoelectric Effect

Quartz is a piezoelectric material. When an electric field is placed upon it, a physical displacement occurs. Interestingly enough, we can write an equivalent electrical circuit to represent the mechanical properties of the crystal.

Equivalent Circuit

The schematic symbol for a quartz crystal is shown in Figure 8 (A). The equivalent circuit for a quartz crystal near fundamental resonance is shown in Figure 8 (B). The equivalent circuit is an electrical representation of the quartz crystal's mechanical and electrical behavior. It does not represent actual circuit components. The crystal is, after all, a vibrating piece of quartz. The components C_1 , L_1 , and R_1 are called the motional arm and represents the mechanical behavior of the crystal element. C_0 represents the electrical behavior of the crystal element and holder.

FIGURE 8: CRYSTAL EQUIVALENT CIRCUIT

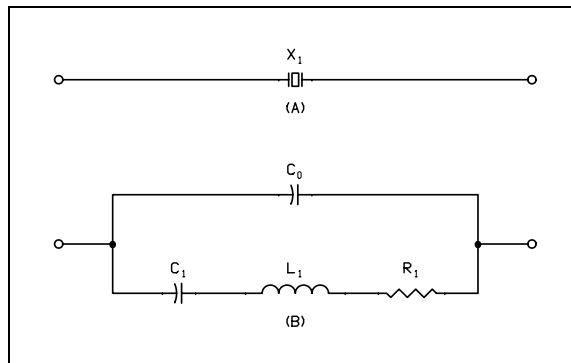

The equivalent circuit in Figure 8 (B) represents one Oscillation mode. For the types of crystal oscillators we are interested in, we will focus on **Fundamental mode** crystals. A more complex model can represent a crystal through as many overtones as desired. For the sake of simplicity this simple model is usually employed and different values are used to model Fundamental or Overtone modes. **Spurious resonances** occur at frequencies near the desired resonance. In a high quality crystal, the motional resistance of Spurious modes are at least two or three times the primary resonance resistance and the Spurious modes may be ignored [3].

C_1 represents **motional arm capacitance** measured in Farads. It represents the elasticity of the quartz, the area of the electrodes on the face, thickness and shape of the quartz wafer. Values of C_1 range in femtofarads (10^{-15} F or 10^{-3} pF).

L_1 represents **motional arm inductance** measured in Henrys. It represents the vibrating mechanical mass of the quartz in motion. Low frequency crystals have

thicker and larger quartz wafers and range in a few Henrys. High frequency crystals have thinner and smaller quartz wafers and range in a few millihenrys.

R_1 represents **resistance** measured in ohms. It represents the real resistive losses within the crystal. Values of R_1 range from 10 Ω for 20 MHz crystals to 200K Ω for 1 kHz crystals.

C_0 represents **shunt capacitance** measured in Farads. It is the sum of capacitance due to the electrodes on the crystal plate plus stray capacitances due to the crystal holder and enclosure. Values of C_0 range from 3 to 7 pF.

Example Crystal

Now that each of the equivalent components of a crystal have been introduced, let's look at an example crystal's electrical specifications that you would find in a crystal data sheet or parts catalog. See Table 1.

TABLE 1: EXAMPLE CRYSTAL SPECIFICATIONS

Parameter	Value
Frequency (f_{XTAL})	8.0 MHz
Load Capacitance (C_L)	13 pF
Mode of Operation	Fundamental
Shunt Capacitance (C_0)	7 pF (maximum)
Equivalent Series Resistance (ESR)	100 Ω (maximum)

When purchasing a crystal, the designer specifies a particular frequency along with load capacitance and mode of operation. Notice that shunt capacitance C_0 is typically listed as a maximum value, not an absolute value. Notice also that motional parameters C_1 , L_1 , and R_1 are not typically given in the crystal data sheet. You must get them from the crystal manufacturer or measure them yourself. Equivalent Series Resistance (ESR) should not be confused with R_1 .

For our example crystal the equivalent circuit values are:

TABLE 2: EXAMPLE EQUIVALENT CIRCUIT CRYSTAL VALUES

Equivalent Component	Value
C_0	4.5 pF
C_1	0.018 pF
L_1	22 mH
R_1	30 Ω

In Table 2 shunt capacitance is given as an absolute value. Shunt capacitance can be measured with a capacitance meter at a frequency much less than the fundamental frequency.

Crystal Resonant Frequencies

A crystal has two resonant frequencies characterized by a zero phase shift. The first is the **series resonant**, f_s , frequency. The equation is:

$$f_s = \frac{1}{2\pi\sqrt{L_1 C_1}}$$

You may recognize this as the basic equation for the resonant frequency of an inductor and capacitor in series. Recall that series resonance is that particular frequency which the inductive and capacitive reactances are equal and cancel: $X_{L1} = X_{C1}$. When the crystal is operating at its series resonant frequency the impedance will be at a minimum and current flow will be at a maximum. The reactance of the shunt capacitance, X_{C0} , is in parallel with the resistance R_1 . At resonance, the value of $X_{C0} \gg R_1$, thus the crystal appears resistive in the circuit at a value very near R_1 .

Solving f_s for our example crystal we find:

$$f_s = 7,997,836.8 \text{ Hz}$$

The second resonant frequency is the **anti-resonant**, f_a , frequency. The equation is:

$$f_a = \frac{1}{2\pi\sqrt{L_1 \times \frac{C_1 C_0}{C_1 + C_0}}}$$

This equation combines the parallel capacitance of C_0 and C_1 . When a crystal is operating at its anti-resonant frequency the impedance will be at its maximum and current flow will be at its minimum.

Solving f_a for our example crystal we find:

$$f_a = 8,013,816.5 \text{ Hz}$$

Observe that f_s is less than f_a and that the specified crystal frequency is between f_s and f_a such that

$$f_s < f_{XTAL} < f_a$$

This area of frequencies between f_s and f_a is called the **"area of usual parallel resonance"** or simply "parallel resonance."

Crystal Complex Impedances

The crystal has both resistance and reactance and therefore impedance. Figure 8 has been redrawn in Figure 9 to show the complex impedances of the equivalent circuit.

FIGURE 9: CRYSTAL EQUIVALENT CIRCUIT COMPLEX IMPEDANCES

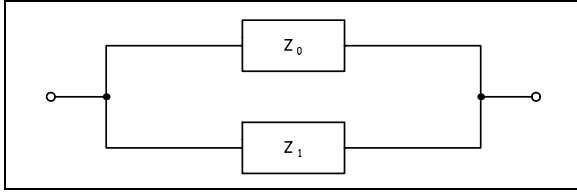

The complex impedances [5] are defined as:

$$Z_0 = \frac{-j}{2\pi f C_0}$$

$$Z_1 = R_1 + j\left(2\pi f L_1 - \frac{1}{2\pi f C_1}\right)$$

Combining Z_0 and Z_1 in parallel yields:

$$Z_p = \frac{Z_0 Z_1}{Z_0 + Z_1}$$

We plug in the values of Table 2 in a spreadsheet program and solve Z_p over frequency. We observe the reactance versus frequency plot in Figure 10.

FIGURE 10: REACTANCE VERSES FREQUENCY

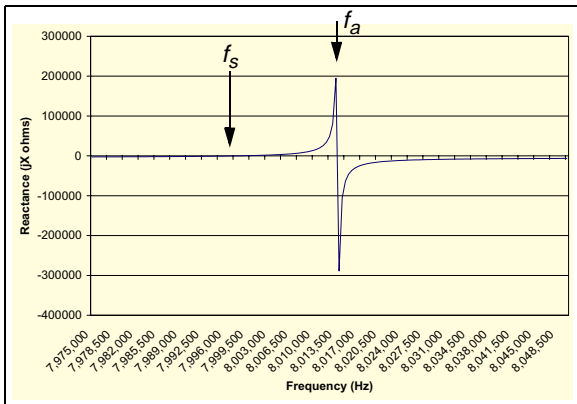

This plot shows where the crystal is inductive or capacitive in the circuit. Recall that positive reactances are inductive and negative reactances are capacitive. We see that between the frequencies f_s and f_a the impedance of the crystal is inductive. At frequencies less than f_s and frequencies greater than f_a the crystal is capacitive.

As mentioned earlier, the equivalent circuit shown in Figure 8 (B) is a simplified model that represents one Oscillation mode. For this example that is the Fundamental mode. The plot in Figure 10 does not show Overtone modes and spurious responses. Therefore, the crystal can appear inductive to the circuit at these Overtone modes and spurious responses. Care must

be taken in the selection of oscillator components, both internal and external, to ensure the oscillator does not oscillate at these points.

Drive Level

Drive level refers to the power dissipated in the crystal. Crystal data sheets specify the maximum drive level the crystal can sustain. Overdriving the crystal can cause excessive aging, frequency shift, and/or quartz fracture and eventual failure. The designer should ensure that the maximum rated drive level of the crystal is not exceeded. Drive level should be maintained at the minimum levels necessary for oscillator start-up and maintain steady-state operation.

Power dissipation of the crystal can be computed by

$$P = \frac{E^2}{R_1}$$

where E is the rms voltage across the crystal exactly at series resonance [3][6]. However, for the crystal oscillators discussed in this Application Note, the crystal operates slightly off series resonance in the **area of usual parallel resonance** (this will be explained in the section on Crystal Oscillators). Therefore, current will need to be measured by using an oscilloscope current probe. Connect the probe on one leg of the crystal, if space permits, or in the oscillator loop. Finally calculate power by

$$P = I^2 R_1$$

Crystal Quality Factor (Q)

Due to the piezoelectric effect of the crystal, a physical displacement occurs when an electric field is applied. The reverse effect happens when the crystal is deformed: electrical energy is produced across the crystal electrodes. A mechanically resonating crystal is seen from its electrodes as an electrical resonance. Therefore the crystal behaves like a tuned circuit and like a tuned circuit the crystal can store energy. We can quantify the amount of stored energy by stating the **quality factor (Q)** of the crystal. Crystal Q is defined as [5]:

$$Q = \frac{X_{L1}}{R_1} = \frac{1}{X_{C1} R_1}$$

Where X_{L1} (or X_{C1}) is the reactance of L_1 (or C_1) at the operating frequency of the crystal. Do not confuse the operating frequency with f_a or f_s . The operating frequency can be anywhere between f_a or f_s in the **area of usual parallel resonance**.

The Q of a crystal is not normally specified in the data sheets. The Q of standard crystals fall between values of 20,000 and 200,000 [5]. By way of comparison, the Q of a good LC tuned circuit is on the order of 200 [2]. The very high Q of a crystal contributes to the high frequency **stability** of a crystal oscillator.

Series vs Parallel Resonant Crystals

There is no difference in the construction of a series resonant crystal and a parallel resonant crystal, which are manufactured exactly alike. The only difference between them is that the desired operating frequency of the **parallel resonant crystal** is set 100 ppm or so above the series resonant frequency. Parallel resonance means that a small capacitance, called load capacitance (C_L), of 12 to 32 pF (depending on the crystal) should be placed across the crystal terminals to obtain the desired operating frequency [6]. Figure 11 shows load capacitance in parallel with the crystal equivalent circuit.

FIGURE 11: LOAD CAPACITANCE ACROSS THE CRYSTAL

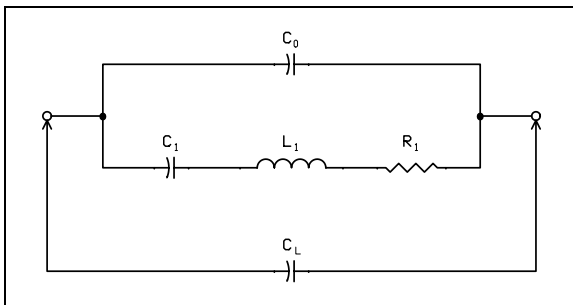

Therefore, when ordering a **series resonance crystal**, load capacitance C_L is not specified. It is implied as zero. These crystals are expected to operate in a circuit designed to take advantage of the crystals mostly resistive nature at series resonance.

On the other hand, a parallel resonant crystal has a load capacitance specified. This is the capacitive load the crystal expects to see in the circuit and thus operate at the frequency specified. If the load capacitance is something other than what the crystal was designed for, the operating frequency will be offset from the specified frequency.

Crystal Pulling

Series or parallel resonance crystals can be **pulled** from their specified operating frequency by adjusting the load capacitance (C_L) the crystal sees in the circuit. An approximate equation for crystal pulling limits is:

$$\Delta f = f_s \left(\frac{C_1}{2(C_0 + C_L)} \right)$$

Where Δf is the pulled crystal frequency (also known as the load frequency) minus f_s .

The limits of Δf depend on the crystal Q and stray capacitance of the circuit. If the shunt capacitance, motional capacitance, and load capacitance is known, the average pulling per pF can be found using:

$$\text{ppm/pF} = \frac{C_1 \times 10^6}{2(C_0 + C_L)^2}$$

Crystal pulling can be helpful when we wish to tune the circuit to the exact operating frequency desired. Examples are **voltage controlled oscillators** (VCO) where the load capacitance is changed with a varactor diode which can be adjusted electrically. Another example is pulling the crystal for Frequency Shift Keying (FSK) modulation. One capacitance value equates to an operating frequency to represent a binary 1. A second capacitance value equates to an operating frequency to represent a binary 0. This is the method the rfPIC12C509AF uses for FSK modulation.

Crystal pulling can be harmful if the printed circuit board exhibits stray capacitance and inadvertently pulls the crystal off the desired operating frequency.

Equivalent Series Resistance

The Equivalent Series Resistance (ESR) is the resistance the crystal exhibits at the series resonant frequency (f_s). It should not be confused with motional resistance (R_1). ESR is typically specified as a maximum resistance value (in ohms).

The resistance of the crystal at any load capacitance (C_L) is called the **effective resistance, R_e** . It can be found using [5]:

$$R_e = R_1 \left(\frac{C_L + C_0}{C_L} \right)^2$$

CRYSTAL OSCILLATORS

We see that a quartz crystal is a tuned circuit with a very high Q . This and many other desirable attributes make the crystal an excellent component choice for oscillators. Crystal oscillators are recognizable from their LC oscillator counterparts [4]. For the Pierce and Colpitts oscillators, the crystal replaces the inductor in the corresponding LC tuned circuit oscillators. Not surprisingly, the crystal will appear inductive in the circuit. Recall the crystal's equivalent circuit of Figure 8 when reviewing crystal oscillator operation.

Crystal Oscillator Operation

Upon start-up, the amplitude of oscillation builds up to the point where nonlinearities in the amplifier decrease the loop gain to unity. During steady-state operation, the crystal, which has a large reactance-frequency slope as we saw in Figure 10, is located in the feedback network at a point where it has the maximum influence on the frequency of oscillation. A crystal oscillator is

unique in that the impedance of the crystal changes so rapidly with frequency that all other circuit components can be considered to be of constant reactance, this reactance being calculated at the nominal frequency of the crystal. The frequency of oscillation will adjust itself so that the crystal presents a reactance to the circuit which will satisfy the Barkhausen phase requirement [5].

Figure 12 again shows a simplified oscillator circuit drawn with only the RF components, no biasing resistors, and no ground connection [3]. The inductor has been replaced by a crystal. We shall see for the Pierce and Colpitts crystal oscillators, the crystal will appear inductive in the circuit in order to oscillate.

FIGURE 12: SIMPLIFIED CRYSTAL OSCILLATOR CIRCUIT WITHOUT RF GROUND

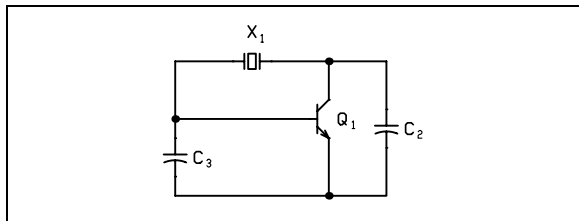

Pierce Crystal Oscillator

The Pierce crystal oscillator (Figure 13) is a series resonant circuit for Fundamental mode crystals. It oscillates just above the series resonant frequency of the crystal [3]. The Pierce oscillator is designed to look into the lowest possible impedance across the crystal terminals [6].

FIGURE 13: PIERCE CRYSTAL OSCILLATOR

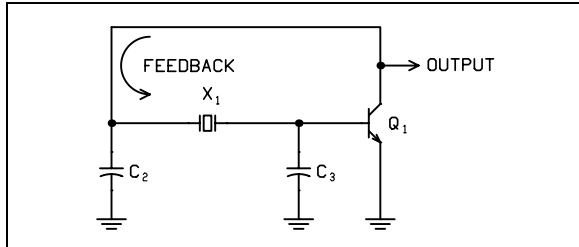

In the Pierce oscillator, the ground point location has a profound effect on the performance. Large phase shifts in RC networks and large shunt capacitances to ground on both sides of the crystal make the oscillation frequency relatively insensitive to small changes in series resistances or shunt capacitances. In addition, RC roll-off networks and shunt capacitances to ground minimize any transient noise spikes which give the circuit a high immunity to noise [6].

At series resonance, the crystal appears resistive in the circuit (Figure 14) and the phase shift around the circuit is 2π radians (360 degrees). If the frequency of the circuit shifts above or below the series resonant

frequency of the crystal, it poses more or less phase shift such that the total is not equal to 360 degrees. Therefore, steady-state operation is maintained at the crystal frequency. However, this only happens in an ideal circuit.

FIGURE 14: PIERCE CRYSTAL OSCILLATOR, IDEAL OPERATION [6]

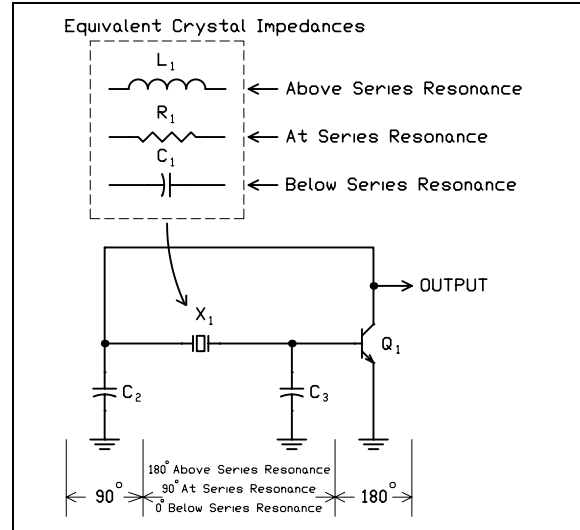

In actual circuit operation (Figure 15), the phase shift through the transistor is typically more than 180 degrees because of increased delay and the tuned circuit typically falls short of 180 degrees. Therefore the crystal must appear inductive to provide the phase shift needed in the circuit to sustain oscillation.

FIGURE 15: PIERCE CRYSTAL OSCILLATOR, ACTUAL OPERATION [6]

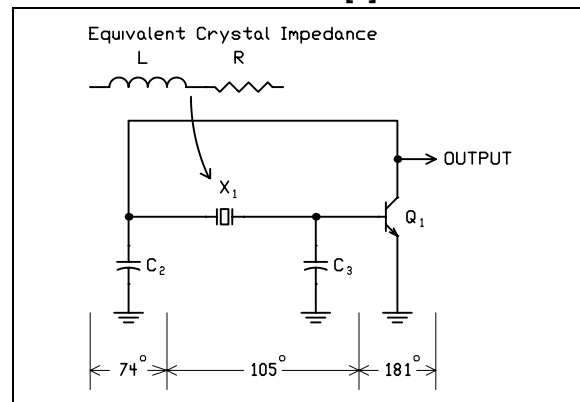

Thus the output frequency of the Pierce crystal oscillator is not at the crystal series resonant frequency. Typically a **parallel resonant crystal** is specified by frequency and load capacitance (C_L). C_L is the circuit capacitance the crystal expects to see and operate at the desired frequency. The circuit load capacitance is determined by external capacitors C2 and C3, transistor

internal capacitance, and stray capacitance (C_S). The product design engineer selects the values of capacitors C2 and C3 to match the crystal C_L using the below equation:

$$C_L = \frac{C_2 C_3}{C_2 + C_3} + C_S$$

Stray capacitance can be assumed to be in the range of 2 to 5 pF. PCB stray capacitance can be minimized by keeping traces as short as possible. A desirable characteristic of the Pierce oscillator is the effects of stray reactances and biasing resistors appear across the capacitors C2 and C3 in the circuit rather than the crystal.

If the circuit load capacitance does not equal the crystal C_L , the operating frequency of the Pierce oscillator will not be at the specified crystal frequency. For example, if the crystal C_L is kept constant and the values of C2 and C3 are increased, the operating frequency approaches the crystal series resonant frequency (i.e., the operating frequency of the oscillator decreases). Care should be used in selecting values of C2 and C3. Large values increase frequency stability but decrease the loop gain and may cause oscillator start-up problems. Typically the values of C2 and C3 are equal. A trimmer capacitor can be substituted for C2 or C3 in order to manually tune the Pierce oscillator to the desired frequency. Select capacitors with a low temperature coefficient such as NP0 or C0G types.

Colpitts Crystal Oscillator

The Colpitts crystal oscillator (Figure 16) is a parallel resonant circuit for Fundamental mode crystals [3]. The Colpitts is designed to look into a high impedance across the crystal terminals [6]. The series combination of C2 and C3, in parallel with the effective transistor input capacitance, form the crystal loading capacitance [3]. The effects of stray reactances appear across the crystal. The biasing resistors are also across the crystal, which can degrade performance as mentioned in the LC version.

FIGURE 16: COLPITTS CRYSTAL OSCILLATOR

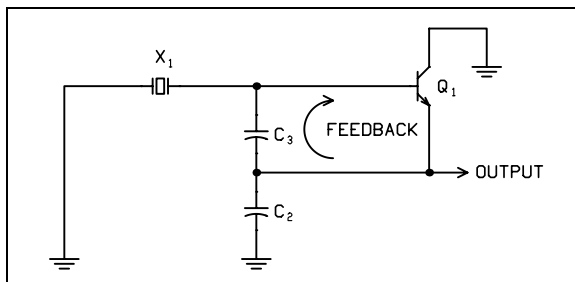

In the particular Colpitts configuration shown in Figure 16, the capacitive divider off the tuned circuit provides the feedback as in a classic LC Colpitts. However, the crystal grounds the gate at the series resonant fre-

quency of the crystal, permitting the loop to have sufficient gain to sustain oscillations at that frequency only [4]. This configuration is useful because only one pin is required to connect the external crystal to the device. The other terminal of the crystal is grounded.

A trimmer capacitor can be placed in series with the crystal to manually tune the Colpitts oscillator to the desired frequency.

SPECIFYING A CRYSTAL

Now that we know how a crystal behaves in an oscillator circuit, let's review the specification questions asked by the crystal manufacturer:

What crystal frequency do you require?

This is the frequency stamped on the crystal package. It is the desired operational crystal frequency for the circuit. It depends on the mode of operation (fundamental or overtone, series or parallel resonant), and load capacitance. Recall that parallel resonant crystals operate at the specified frequency at the specified load capacitance (C_L) that you request.

Which mode of operation?

Fundamental or overtone. This Application Note focused primarily on Fundamental mode since the rfPIC and PICmicro MCU oscillators generally operate below 30 MHz, which is the upper frequency limit of AT-cut quartz crystals.

Series or parallel resonant?

This tells the crystal manufacturer how the crystal will be used in the oscillator circuit. Series resonant crystals are used in oscillator circuits that contain no reactive components in the feedback loop. Parallel resonant crystals are used in oscillator circuits that contain reactive components. As mentioned, there is no difference in the construction of a series or parallel resonant crystal.

For the Pierce and Colpitts oscillators reviewed in this Application Note, the crystal is used at its parallel resonant frequency. Therefore, a load capacitance must be specified in order for the crystal to operate at the frequency stamped on the package.

What frequency tolerance do you desire?

This is the allowable frequency deviation plus and minus the specified crystal frequency. It is specified in parts per million (PPM) at a specific temperature, usually +25 degrees C.

The designer must determine what frequency tolerance is required for the product design. For example, a PICmicro device in a frequency insensitive application the frequency tolerance could be 50 to 100 ppm. For a rfPIC device, the crystal frequency is multiplied up to the transmit frequency. Therefore, the tolerance will be multiplied. The tolerance required depends on the radio frequency regulations of the country the product will be used. Tolerances of 30 ppm or better are generally

required. Care should be taken in selecting low tolerance values as the price of the crystal will increase. The product design engineer should select the crystal frequency tolerance that meets the radio frequency regulations at the price point desired for the product.

What temperature stability is needed?

This is the allowable frequency plus and minus deviation over a specified temperature range. It is specified in parts per million (PPM) referenced to the measured frequency at +25 degrees C.

Temperature stability depends on the application of the product. If a wide temperature stability is required, it should be communicated to the crystal manufacturer.

What temperature range will be required?

Temperature range refers to the operating temperature range. Do not confuse this with temperature stability.

Which enclosure (holder) do you desire?

There are many crystal enclosures to choose from. You can select a surface mount or leaded enclosure. Consult with the crystal manufacturer about your product needs. Bear in mind that the smaller the enclosure, the higher the cost. Also, the smaller the enclosure the higher the series resistance. Series resistance becomes an issue because it lowers the loop gain of the oscillator. This can result in oscillator not starting or stopping over a wide temperature range.

What load capacitance (C_L) do you require?

This is the capacitance the crystal will see in the circuit and operate at the specified frequency. Load capacitance is required for parallel resonant crystals. It is not specified for series resonant crystals.

What shunt capacitance (C_0) do you require?

Shunt capacitance contributes to the oscillator circuit capacitance. Therefore, it has to be taken into account for circuit operation (starting and steady-state) and pullability.

Is pullability required?

Pullability refers to the change in frequency in the **area of usual parallel resonance**. It is important if the crystal is going to be tuned (pulled) over a specific but narrow frequency range. The amount of pullability exhibited by a crystal at the specified load capacitance (C_L) is a function of shunt capacitance (C_0) and motional capacitance (C_1).

This specification is important for the rPIC12C509AF device in FSK mode. The crystal is pulled between two operating frequencies by switching capacitance in and out of the oscillator circuit. If pullability is not specified, there will be a hazard of tuning the crystal out of its operating range of frequencies.

What motional capacitance (C_1) do you require?

Motional capacitance is required if the crystal is going to be tuned (**pulled**) in the circuit.

It is interesting to note that motional inductance (L_1) is normally not specified. Instead it is inferred from the crystal's series resonant frequency (f_a) and motional capacitance (C_1). Simply plug in the values into the crystal series resonant frequency and solve for L_1 .

What Equivalent Series Resistance (ESR) is required?

Typically specified as a maximum resistance in ohms. Recall this is the resistance the crystal exhibits at its *operating* frequency. Do not confuse ESR with motional resistance (R_0). A lower ESR requires a lower drive level and vice versa. A danger exists in specifying too high an ESR where the oscillator will not operate.

What drive level is required?

The quartz crystal is driven by the oscillator amplifier and will dissipate heat. Drive level is the amount of power the quartz crystal will have to dissipate in the oscillator circuit. It is specified in milli- or microwatts. The quartz crystal can only stand a finite amount of current drive. The product design engineer must ensure the quartz crystal is not overdriven or failure of the crystal will result.

Drive level should be maintained at the minimum levels necessary for oscillator start-up and maintain steady-state operation. The design engineer should specify the drive level required by the device and ensure that crystal is not overdriven by measuring the current flow in the oscillator loop. Make certain that the current drive does not exceed the drive level specified by the crystal manufacturer.

PRODUCT TESTING

Once the crystal has been specified and samples obtain, product testing can begin. The final product should be tested at applicable temperature and voltage ranges. Ensure the oscillator starts and maintains oscillation. Include in the evaluation component and manufacturing variations.

SUMMARY

There is much to learn about crystals and crystal oscillators, however, this Application Note can only cover the basics of crystals and crystal oscillators in an effort to assist the product design engineer in selecting a crystal for their rPIC™ or PICmicro® based device. The reader is encouraged to study more in-depth about the design and operation of crystal oscillators because they are such an important component in electronic designs today. Additional reading material is listed in the further reading and references sections of this Application Note. The product design engineer should also consult with the crystal manufacturer about their product design needs.

GLOSSARY

Accuracy - The degree of conformity of a measured or calculated value to its definition or with respect to a standard reference.

Aging - The systematic change in frequency over time because of internal changes in the oscillator. Aging is the frequency change with time when factors external to the oscillator such as environment and power supply are kept constant.

Calibration - The process of identifying and measuring time or frequency errors, offsets, or deviations of a clock/oscillator relative to an established standard.

Drift - The linear (first-order) component of a systematic change in frequency of an oscillator over time. Drift is due to aging plus changes in the environment and other factors external to the oscillator.

Frequency - The rate at which a periodic phenomenon occurs over time.

Offset - The difference between the measured value and the defined value.

Precision - The degree of mutual agreement among a series of individual measurements.

Quality Factor (Q) - The ratio of energy stored in a reactive component (such as a capacitor or inductor) to the energy dissipated. Equal to the reactance divided by the resistance.

Reproducibility - With respect to a set of independent devices of the same design, it is the ability of these devices to produce the same value. With respect to a single device, it is the ability to produce the same value and to put it into operation repeatedly without adjustments.

Resolution - The degree to which a measurement can be determined. The smallest significant difference that can be measured with a given instrument.

Stability - Statistical estimate of the [frequency] fluctuations of a signal over a given time interval.

- Short term stability - usually involves measurement averages from a few tenths of a second to 100 seconds.
- Long term stability - usually involves measurement averages beyond 100 seconds.

Synchronization - The process of measuring the difference in time of two time scales such as the output signals generated by two clocks. In the context of timing, synchronization means to bring two clocks or data streams into phase so that their difference is zero.

Tolerance - The maximum allowable frequency deviation from the specified frequency. It is specified in parts per million (PPM) at a specific temperature, usually +25 degrees C.

FURTHER READING

There are several excellent tutorials on frequency control devices at the IEEE Ultrasonics, Ferroelectrics and Frequency Control web site. The URL is

<http://www.ieee-uffc.org>

Several crystal manufacturers have application notes about crystal and crystal oscillator operation. Refer to the individual crystal manufacturers' web sites.

REFERENCES

- [1] B. Razavi, *RF Microelectronics*, Prentice Hall PTR, Upper Saddle River, NJ, 1998.
- [2] *The ARRL Handbook for Radio Amateurs*, ARRL, Newington, CT, 2001 (published annually).
- [3] R. W. Rhea, *Oscillator Design and Computer Simulation*, 2nd edition, Noble Publishing, Atlanta, GA, 1995.
- [4] T. H. Lee, *The Design of CMOS Radio-Frequency Integrated Circuits*, Cambridge University Press, New York, NY, 1998.
- [5] M. E. Frerking, *Crystal Oscillator Design and Temperature Compensation*, Van Nostrand Reinhold Company, New York, 1978.
- [6] R. J. Matthys, *Crystal Oscillator Circuits*, Revised Edition, Krieger Publishing Company, Malabar, FL, 1992

AN826

NOTES:

Note the following details of the code protection feature on PICmicro® MCUs.

- The PICmicro family meets the specifications contained in the Microchip Data Sheet.
- Microchip believes that its family of PICmicro microcontrollers is one of the most secure products of its kind on the market today, when used in the intended manner and under normal conditions.
- There are dishonest and possibly illegal methods used to breach the code protection feature. All of these methods, to our knowledge, require using the PICmicro microcontroller in a manner outside the operating specifications contained in the data sheet. The person doing so may be engaged in theft of intellectual property.
- Microchip is willing to work with the customer who is concerned about the integrity of their code.
- Neither Microchip nor any other semiconductor manufacturer can guarantee the security of their code. Code protection does not mean that we are guaranteeing the product as “unbreakable”.
- Code protection is constantly evolving. We at Microchip are committed to continuously improving the code protection features of our product.

If you have any further questions about this matter, please contact the local sales office nearest to you.

Information contained in this publication regarding device applications and the like is intended through suggestion only and may be superseded by updates. It is your responsibility to ensure that your application meets with your specifications. No representation or warranty is given and no liability is assumed by Microchip Technology Incorporated with respect to the accuracy or use of such information, or infringement of patents or other intellectual property rights arising from such use or otherwise. Use of Microchip's products as critical components in life support systems is not authorized except with express written approval by Microchip. No licenses are conveyed, implicitly or otherwise, under any intellectual property rights.

Trademarks

The Microchip name and logo, the Microchip logo, FilterLab, KEELOQ, MPLAB, PIC, PICmicro, PICMASTER, PICSTART, PRO MATE, SEEVAL and The Embedded Control Solutions Company are registered trademarks of Microchip Technology Incorporated in the U.S.A. and other countries.

dsPIC, ECONOMONITOR, FanSense, FlexROM, fuzzyLAB, In-Circuit Serial Programming, ICSP, ICEPIC, microID, microPort, Migratable Memory, MPASM, MPLIB, MPLINK, MPSIM, MXDEV, PICC, PICDEM, PICDEM.net, rPIC, Select Mode and Total Endurance are trademarks of Microchip Technology Incorporated in the U.S.A.

Serialized Quick Turn Programming (SQTP) is a service mark of Microchip Technology Incorporated in the U.S.A.

All other trademarks mentioned herein are property of their respective companies.

© 2002, Microchip Technology Incorporated, Printed in the U.S.A., All Rights Reserved.

 Printed on recycled paper.

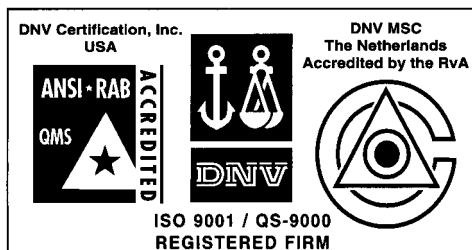

Microchip received QS-9000 quality system certification for its worldwide headquarters, design and wafer fabrication facilities in Chandler and Tempe, Arizona in July 1999. The Company's quality system processes and procedures are QS-9000 compliant for its PICmicro® 8-bit MCUs, KEELOQ® code hopping devices, Serial EEPROMs and microperipheral products. In addition, Microchip's quality system for the design and manufacture of development systems is ISO 9001 certified.



WORLDWIDE SALES AND SERVICE

AMERICAS

Corporate Office

2355 West Chandler Blvd.
Chandler, AZ 85224-6199
Tel: 480-792-7200 Fax: 480-792-7277
Technical Support: 480-792-7627
Web Address: <http://www.microchip.com>

Rocky Mountain

2355 West Chandler Blvd.
Chandler, AZ 85224-6199
Tel: 480-792-7966 Fax: 480-792-7456

Atlanta

500 Sugar Mill Road, Suite 200B
Atlanta, GA 30350
Tel: 770-640-0034 Fax: 770-640-0307

Boston

2 Lan Drive, Suite 120
Westford, MA 01886
Tel: 978-692-3848 Fax: 978-692-3821

Chicago

333 Pierce Road, Suite 180
Itasca, IL 60143
Tel: 630-285-0071 Fax: 630-285-0075

Dallas

4570 Westgrove Drive, Suite 160
Addison, TX 75001
Tel: 972-818-7423 Fax: 972-818-2924

Dayton

Two Prestige Place, Suite 130
Miamisburg, OH 45342
Tel: 937-291-1654 Fax: 937-291-9175

Detroit

Tri-Atria Office Building
32255 Northwestern Highway, Suite 190
Farmington Hills, MI 48334
Tel: 248-538-2250 Fax: 248-538-2260

Kokomo

2767 S. Albright Road
Kokomo, Indiana 46902
Tel: 765-864-8360 Fax: 765-864-8387

Los Angeles

18201 Von Karman, Suite 1090
Irvine, CA 92612
Tel: 949-263-1888 Fax: 949-263-1338

New York

150 Motor Parkway, Suite 202
Hauppauge, NY 11788
Tel: 631-273-5305 Fax: 631-273-5335

San Jose

Microchip Technology Inc.
2107 North First Street, Suite 590
San Jose, CA 95131
Tel: 408-436-7950 Fax: 408-436-7955

Toronto

6285 Northam Drive, Suite 108
Mississauga, Ontario L4V 1X5, Canada
Tel: 905-673-0699 Fax: 905-673-6509

ASIA/PACIFIC

Australia

Microchip Technology Australia Pty Ltd
Suite 22, 41 Rawson Street
Epping 2121, NSW
Australia
Tel: 61-2-9868-6733 Fax: 61-2-9868-6755

China - Beijing

Microchip Technology Consulting (Shanghai)
Co., Ltd., Beijing Liaison Office
Unit 915
Bei Hai Wan Tai Bldg.
No. 6 Chaoyangmen Beidajie
Beijing, 100027, No. China
Tel: 86-10-85282100 Fax: 86-10-85282104

China - Chengdu

Microchip Technology Consulting (Shanghai)
Co., Ltd., Chengdu Liaison Office
Rm. 2401, 24th Floor,
Ming Xing Financial Tower
No. 88 TIDU Street
Chengdu 610016, China
Tel: 86-28-6766200 Fax: 86-28-6766599

China - Fuzhou

Microchip Technology Consulting (Shanghai)
Co., Ltd., Fuzhou Liaison Office
Rm. 531, North Building
Fujian Foreign Trade Center Hotel
73 Wusi Road
Fuzhou 350001, China
Tel: 86-591-7557563 Fax: 86-591-7557572

China - Shanghai

Microchip Technology Consulting (Shanghai)
Co., Ltd.
Room 701, Bldg. B
Far East International Plaza
No. 317 Xian Xia Road
Shanghai, 200051
Tel: 86-21-6275-5700 Fax: 86-21-6275-5060

China - Shenzhen

Microchip Technology Consulting (Shanghai)
Co., Ltd., Shenzhen Liaison Office
Rm. 1315, 13/F, Shenzhen Kerry Centre,
Renminnan Lu
Shenzhen 518001, China
Tel: 86-755-2350361 Fax: 86-755-2366086

Hong Kong

Microchip Technology Hongkong Ltd.
Unit 901-6, Tower 2, Metroplaza
223 Hing Fong Road
Kwai Fong, N.T., Hong Kong
Tel: 852-2401-1200 Fax: 852-2401-3431

India

Microchip Technology Inc.
India Liaison Office
Divyasree Chambers
1 Floor, Wing A (A3/A4)
No. 11, O'Shaughnessy Road
Bangalore, 560 025, India
Tel: 91-80-2290061 Fax: 91-80-2290062

Japan

Microchip Technology Japan K.K.
Benex S-1 6F
3-18-20, Shinyokohama
Kohoku-Ku, Yokohama-shi
Kanagawa, 222-0033, Japan
Tel: 81-45-471-6166 Fax: 81-45-471-6122

Korea

Microchip Technology Korea
168-1, Youngbo Bldg. 3 Floor
Samsung-Dong, Kangnam-Ku
Seoul, Korea 135-882
Tel: 82-2-554-7200 Fax: 82-2-558-5934

Singapore

Microchip Technology Singapore Pte Ltd.
200 Middle Road
#07-02 Prime Centre
Singapore, 188980
Tel: 65-334-8870 Fax: 65-334-8850

Taiwan

Microchip Technology Taiwan
11F-3, No. 207
Tung Hua North Road
Taipei, 105, Taiwan
Tel: 886-2-2717-7175 Fax: 886-2-2545-0139

EUROPE

Denmark

Microchip Technology Nordic ApS
Regus Business Centre
Lautrup høj 1-3
Ballerup DK-2750 Denmark
Tel: 45 4420 9895 Fax: 45 4420 9910

France

Microchip Technology SARL
Parc d'Activite du Moulin de Massy
43 Rue du Saule Trapu
Batiment A - 1er Etage
91300 Massy, France
Tel: 33-1-69-53-63-20 Fax: 33-1-69-30-90-79

Germany

Microchip Technology GmbH
Gustav-Heinemann Ring 125
D-81739 Munich, Germany
Tel: 49-89-627-144 0 Fax: 49-89-627-144-44

Italy

Microchip Technology SRL
Centro Direzionale Colleoni
Palazzo Taurus 1 V. Le Colleoni 1
20041 Agrate Brianza
Milan, Italy
Tel: 39-039-65791-1 Fax: 39-039-6899883

United Kingdom

Arizona Microchip Technology Ltd.
505 Eskdale Road
Winnersh Triangle
Wokingham
Berkshire, England RG41 5TU
Tel: 44 118 921 5869 Fax: 44-118 921-5820

10/01/01