

Chapter 3. Liquid Crystal Displays and Plasmatron

3.1 Introduction

In the early 1970's, digital watches started showing up in the marketplace with a new and different type of display—the liquid crystal display or LCD. The LCD displays used in these early digital watches were very different from the LEDs they replaced. While even a tiny LED display consumes a few milliwatts of power, the LCD consumes just microwatts of power. Hence, the LCDs are over 1000 times more efficient at their job than the LEDs.

Since their commercialization in the '70s, LCDs are the most popular electronic display device, except one—the CRT. LCD flat full color panels are now challenging the CRT as displays for television and computers. There are also many hybrid systems that use LCD display technology.

3.2 Liquid crystals

There are 3 states of matter: solid, liquid, gas.

Solids states can be further categorised into: crystalline which has regular arrangement of molecules; and amorphous where there is no regular structure. It is well known that

Crystalline solids ——— *heat* ———→ *Isotropic liquid*.

In 1888, an intermediate phase is discovered and is known as the crystalline liquid or liquid crystal. This phase is called the **nematic** phase. An example is 4-n-pentyl-4'-cyano-biphenyl (PCB). Since then, over 20,000 known compounds have been found to have the nematic phase.

The main interest in these types of compound is that the nematic phase compounds with rod-like molecules can be aligned by varying an external electric field.

Most of the liquid crystal displays (LCDs) produced today use either the twisted nematic (TN) or supertwisted nematic (STN) electro-optical effects.

3.2.1 Types of LCDs

There are many types of LCDs.

- Dynamic Scattering: Higher voltage, higher power, less legible, now obsolete.

- FLC (Ferroelectric Liquid Crystal) Bistable, faster switching times ($\sim 2\text{MHz}$), can achieve good grayscale by rubbing process.
- TN: Twisted Nematic
- STN: Super-twisted Nematic
- TFT: Thin Film Transistor Active Matrix TN

We will only cover the last three types in our lectures.

3.2.2 Power Requirements

The LCDs have minimal power requirements. Currently manufactured LCDs consume between 1 and 300 microwatts per square centimeter. This is the lowest power consumption of any display type now available. This very low power consumption allows most LCD products to be battery operated.

3.2.3 Market Niches for various LCD technologies

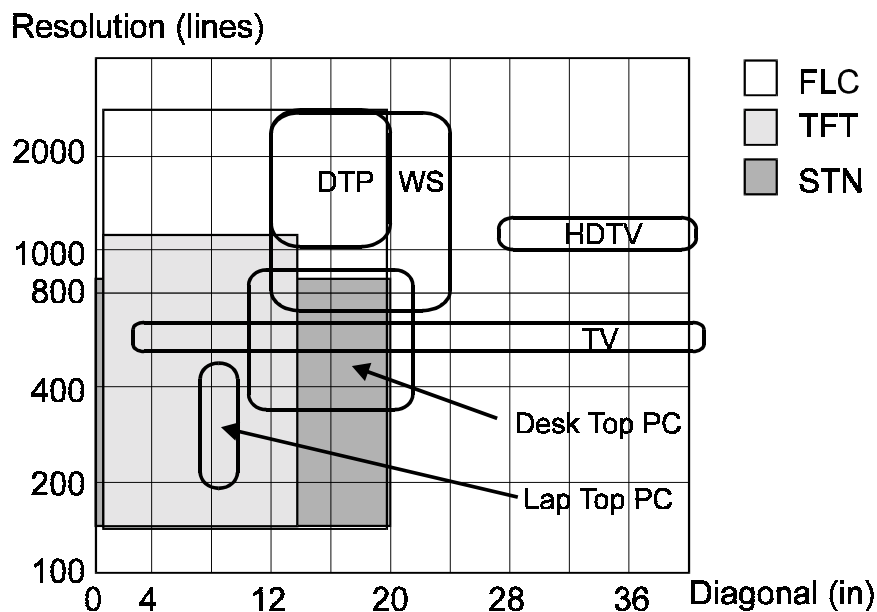

The above data was taken in 1994 and may not represent the current market information.

3.3 How LCDs WORK

LCDs are light valves. The principle of the liquid crystal display's operation is radically different from all other display devices. LCDs are light modifiers, not light producers. All the other devices are self-illuminating as they produce their own light. The LCD does not make its own light, but operates by modifying light from other sources. This distinction is very important and is responsible for the low power consumption of the LCD. The external light modified by the LCD may be ambient light or a special light source installed within the device just to supply the LCD some light to modify. Since most of special light source come from the back of the LCD panel, hence it is commonly known as back-lit LCD.

In order to understand the principle of the LCD's operation, we must first understand the idea of light's polarization. Light is a traveling wavefront of photons. These photonic wavefronts are a transverse (perpendicular) combination of electric and magnetic fields. The electric and magnetic fields are perpendicular to each other and to the direction of the wavefront's propagation. The orientation of these fields gives each individual light wavefront a distinct polarization. By this we mean that the electric and magnetic fields are oriented in a certain angular direction (Figure 0-1 Light wavefronts). Polarization is in the plane of the Electric field and propagation direction.

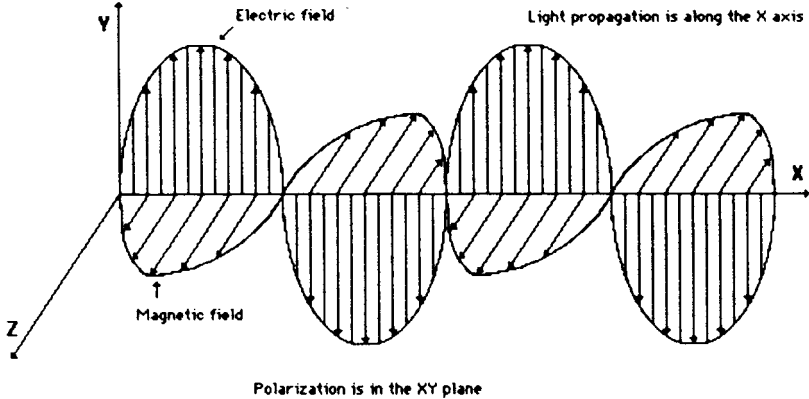

Figure 0-1 Light wavefronts

Ambient light is a combination of photon wavefronts of an infinite variety of polarizations, which is unpolarized. Polarizers are light filters which only allow light of a single polarization to pass through them. A polarizing filter is a network of infinitesimally small parallel lines. These lines are constructed on the molecular level by the transparent chemical compounds that make up the filter. The polarizing filter will only allow light waves parallel to the filter's lines to pass through it. The light of all other polarizations is either reflected or absorbed by the filter. Light which passes through a polarizing filter is said to be polarized and is coherent (Figure 0-2 Operation of a polarizing filter). Two polarizing filters can be used together to stop the transmission of light. (Figure 0-1 Light wavefronts)

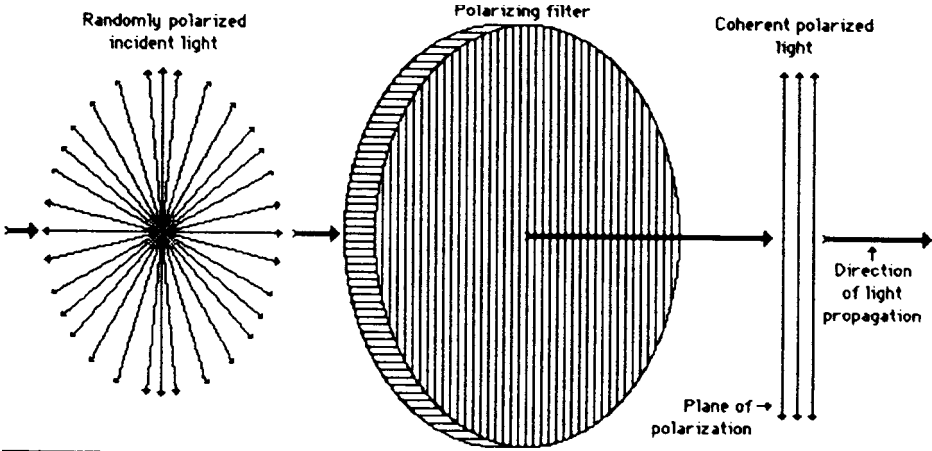

Figure 0-2 Operation of a polarizing filter

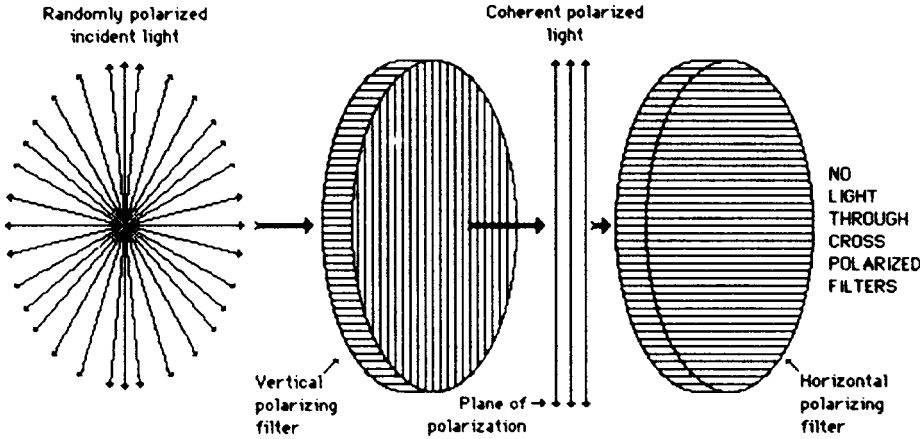

Figure 0-3 Operation of two polarizing filters

3.4 Principle of operation of TN display

We will explain the operation of an LCD with a Twisted Nematic display.

3.4.1 Simple Explanation of TN Operation

The LCD uses a system of filters to display information that is similar to the operation of the polarizers. Ambient light enters the LCD display through the front polarizing filter. The coherent light then passes through the liquid crystal medium. This liquid crystal medium is a collection of specific organic molecules which rotate the light passing through them. They change the polarization of the coherent light passed to them.

This rotation of the light's polarization may be from just a few degrees to over 270 degrees. In most liquid crystal compounds used in manufacturing LCDs, the amount of rotation of the light's polarization is 90 degrees.

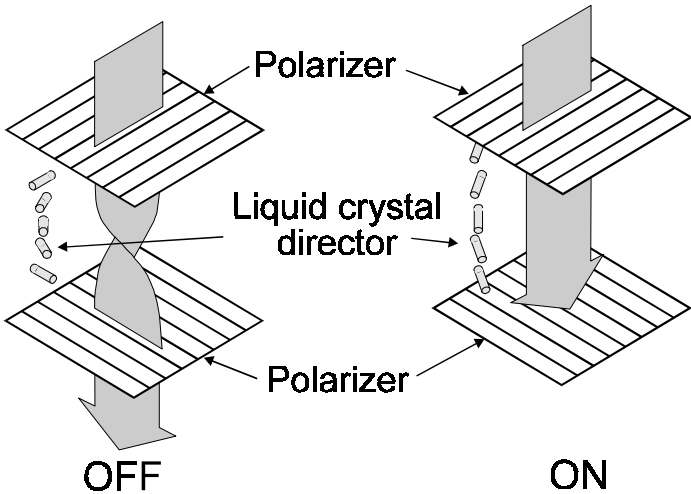

Figure 0-4 Principle of operation of a twisted nematic display in the normally white mode.

In the OFF mode the local optic axis undergoes a continuous 90 degrees twist in the unactivated state, and allow the light to passed through the second polarizing filter.

Applying 3-5 volts across the upper and lower electrodes orients the optic axis in the central portion of the LC layer predominantly parallel to the electric field and the twisted structure disappears (ON mode). The polarization direction of the light is no longer rotated and light passing through the cell intersects the second polarizer in the crossed position where it is absorbed, causing the activated portion of the display to appear dark.

This arrangement of the TN cell and polarizers is known as the normally white mode of operation because the display is bright in the un-activated state.

Also available is the normally black operation where polarizers are aligned in parallel.

3.4.2 Construction of TN display

The construction and basic operation of a twisted nematic (TN) display is illustrated in Figure 0-5 Basic LCD construction. The upper and lower substrate plates, separated by a gap of 6-8 μm , carry patterned, transparent conductive coatings (transparent electrodes) of Indium-Tin Oxide (ITO) on their inner surfaces.

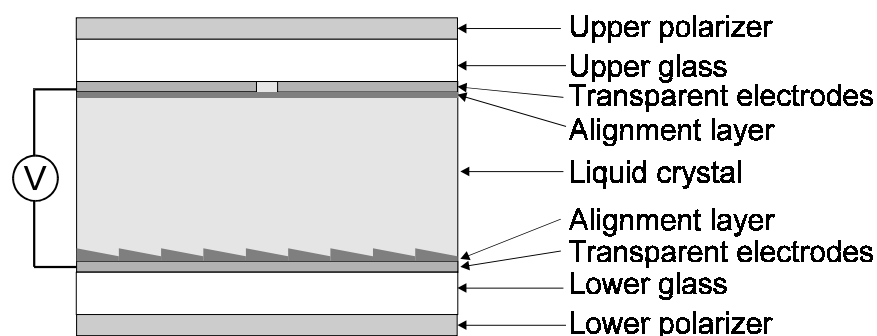

Light

Figure 0-5 Basic LCD construction

These electrodes are patterned on the glass by photolithography. These patterns of electrodes are transparent. They lay like a grid over the display. Each cell has two electrodes, one which is distinctly its own and another shared in common with all the other cells. The common electrode is often called the "backplane" of the LCD.

3.4.3 Behaviour of TN Liquid Crystals

The application of TN liquid crystals depends on behaviour of light propagating along the helical axis of the twisted nematic layer. The propagation of light through a twisted nematic layer is somewhat more complex than the simple picture presented. It can be shown that every monochromatic light wave propagating along the helical axis of a uniformly twisted nematic layer can be described in a local Cartesian coordinate system with one axis parallel to the direction of propagation as followed.

Let n denote the refractive index. The refractive index n fluctuates in nematic LC.

Define

$$\Delta n = n_{\parallel} - n_{\perp} \quad \text{where}$$

n_{\parallel} is the component of light ray oscillating parallel to the director and

n_{\perp} is the ordinary perpendicular beam.

Typical range of Δn is between 0.05 - 0.25

In the normal modes, lights are in general elliptically polarized with the major axis of the vibrational ellipses parallel and perpendicular to the nematic director, respectively. Only in the limit lights can be considered linearly polarized. The condition is known as the Mauguin condition:

$$\Delta n d \gg \frac{\Phi \lambda}{\pi}$$

Φ is the total twist angle,

λ is the wavelength of the light, and

d is the total layer thickness.

For 90° twist, this reduces to:

$$\Delta n d \gg \frac{\lambda}{2}$$

In the liquid crystal layers used in TN displays, this inequality is only approximately fulfilled, resulting in a reduction of the display brightness as well as undesirable coloration caused by optical interference. The elliptically polarized light which dependence on wavelength results in partial transmission, with minima occurring at various values of $\Delta n d$.

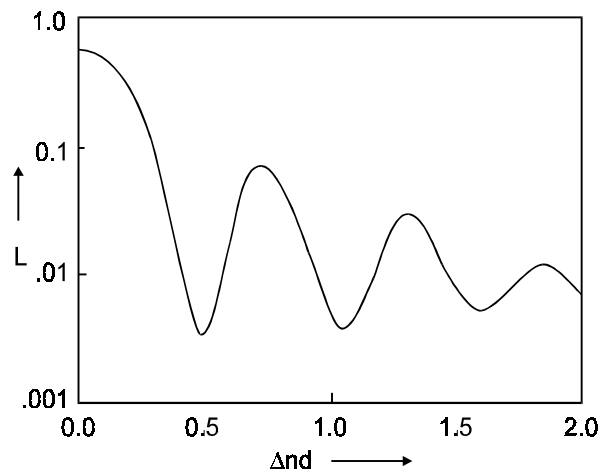

Figure 0-6 Transmission luminance (L) for white light through a TN LCD

Since LCDs are passive devices, hence its performance is measured in the contrast ratio of black and white mode.

For the normally black mode the transmitted luminance of the dark state is primarily determined by light leakage due to the slight ellipticity of the normal modes propagating through the twisted structure. Contrast ratios of about 100:1 can be expected for this mode. In the

normally white mode, the darkest state is achieved when the device is fully turned on and the transmitted of light is determined by alignment and efficiency of polarizers. . In the normally white mode the effect of ellipticity in the un-activated state occurs in the bright state and therefore does not appreciably affect the contrast ratio, although it can introduce coloration. For the normally white mode it is possible to obtain contrast ratios greater than 1000:1.

3.4.4 Viewing Angle

The viewing angle characteristics of the normally black and normally white modes are shown in Figure 0-7 Iso-contrast viewing diagram of the normally black mode LCD. and Figure 0-8 Iso-contrast viewing diagram of the normally white mode LCD., where curves of equal contrast ratio (here 20:1 and 100:1) are presented in polar diagrams, known as iso-contrast diagrams. Every point on these diagrams corresponds to a certain viewing direction characterized by a polar and an azimuthal angle. The center of the diagrams refers to on-axis viewing. For a good display it is desire to have good contrast over a wide viewing angle.

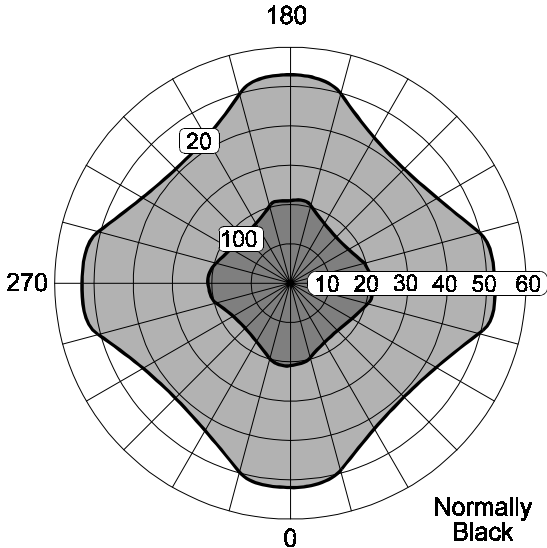

Figure 0-7 Iso-contrast viewing diagram of the normally black mode LCD.

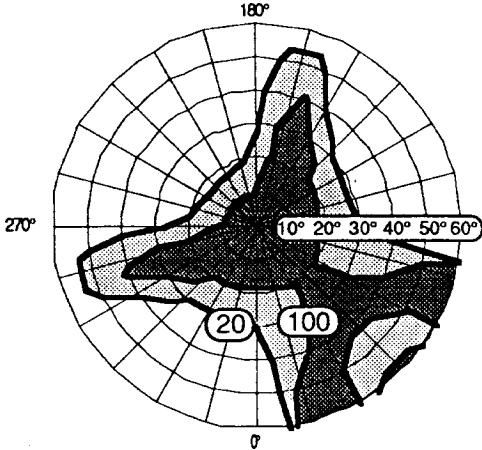

Figure 0-8 Iso-contrast viewing diagram of the normally white mode LCD.

3.4.5 Colour balance

Polarization and twist angle depend on wavelength, so components of white light have varying luminance. Furthermore, a small change in layer thickness or variations in temperature and viewing angle can lead to objectionable color shifts. In the Modulated Twisted Nematic display (MTN) the color shift with thickness variations has been intentionally exploited by roughening one of the substrate plates on a microscopic scale (2-7 μm deep with a period of about 100 μm). The resulting variations in thickness produce small colored areas, which through additive mixing blend to a balance white light (Figure 0-9 Schematic representation of the operation of a modulated TN display.). The M-TN display, however, trades off color variations against contrast ratio.

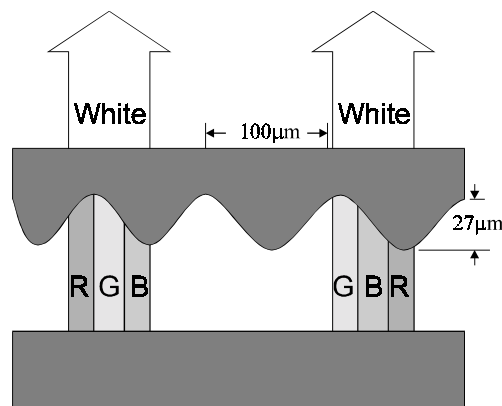

Figure 0-9 Schematic representation of the operation of a modulated TN display.

3.4.6 Colour TN displays

In the direct view TN displays, color is achieved by letting the pixels act as light valves, and control the amount of light passing through the red, green or blue color mosaic filters in the display. Color balance is extremely critical for TV and monitor applications and so the proportion of red, green and blue light in a color triad must remain relatively constant over the full dynamic range. This is difficult to achieve, especially for black, because for a fixed value of Δ and there is only one wavelength where the light transmission is zero for a particular minimum condition. Lights of other wavelengths leak through to produce coloration. One way to block light of all wavelengths to achieve a truly black state would be to make the liquid crystal cell gap d at a particular location proportional to the wavelength of light λ going through it at that same location. By this method the minimum condition is assured for all three primary colour wavelengths. A practical way is the multigap technology (Figure 0-10 Schematic view of the multigap technology used to improve colour balance in TN displays). The thickness of typical red, green and blue mosaic filters is chosen so the cell gap under the filters is 6.4 μm , 5.8 μm and 4.8 μm , respectively. The multigap design not only ensures a true black but also a good color balance over the whole dynamic range of the display.

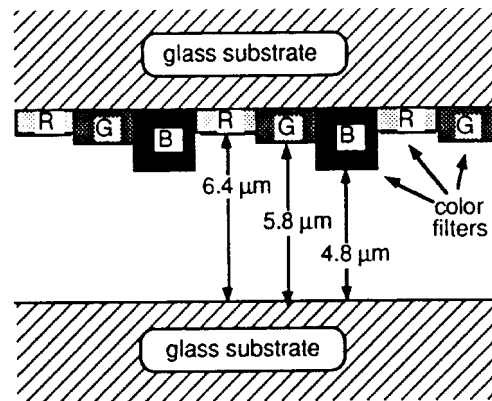

Figure 0-10 Schematic view of the multigap technology used to improve colour balance in TN displays

3.4.7 Limitations of TN

Response time: The response time of the LC depends on the physical alignment of molecules. There is a delay which increases with decreasing temperature. Slow operating speed was one of the problems with the twisted nematic (TN) LCDs. The display simply could not turn its elements on and off fast enough to display moving pictures. The speed of any particular LC cell's operation is greatly dependent on its temperature and drive method. The time it takes the LC cell to respond to this electric field is called the turn-on time. Turn-on time is the sum of two factors. One factor is the turn-on delay before the electric field is established around the crystal, and the other is the rise time it takes the crystal to straighten out under the field's influence. The time it takes the crystal to retwist after the electric field is removed is called the turn-off time. Turn-off time is the sum of turn-off delay and the time it takes the crystal to respond after the field is gone (called decay time). In terms of real time, a typical LC cell will turn-on in 20 ms, and turn-off in 100 ms when the LC cell's temperature is at 20° C. If the temperature is lowered to 0° C, the turn-on time increases to 90 ms, and the turn-off time to 2000 ms. The longer turn-off time than turn-on time is simply the liquid crystal takes more time to retwist itself after the electric field is removed.

3.4.8 Advantages

The major advantage of the TN LCD over other types is cost. The TN LCD is the simplest type of liquid crystal display to manufacture, and its price reflects this.

3.4.9 Disadvantages

The TN LCD suffers from several disadvantages, among which are, restricted viewing angle, slow speed only when displaying moving graphics (like TV), and narrow temperature operating range. However, the operating temperatures within the human environment are well within the display's range.

3.5 Super Twisted Nematic LC

In highly multiplexed computer TN displays, contrast and viewing angle is limited because change in on/off voltage is small. If we increase layer twist to 180° - 270° , we can "tune" the LC twist to layer thickness accurately. To sustain a twist angle greater than 90° requires a nematic liquid crystal with an intrinsically twisted structure known as a chiral nematic. Chiral nematics are ordinary nematic liquid crystals doped with a few percent of optically active material. This type of LC is known as Super Twisted Nematic (STN) LC.

The advantage of STN displays is that they have a much wide range of viewing angles for acceptable contrast.

3.6 LCD Controllers and Drivers

TN LCD do not have sharp threshold voltage to turn on/off.

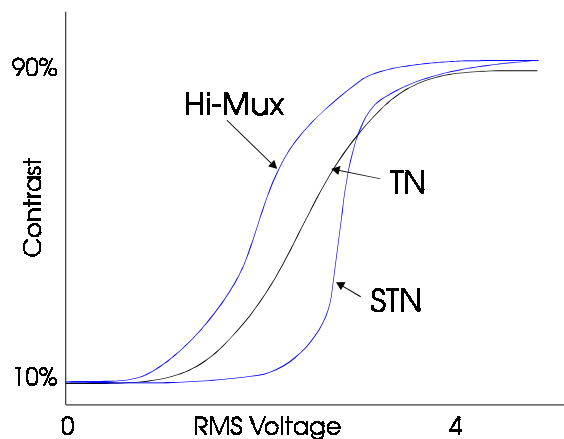

Figure 0-11 comparison of contrast to RMS voltage applied across the LCDs.

Research in LC materials to improve this limitation. The need for small difference in turn on/off is to reduce the requirement in the driving circuitry. Materials that have sharper threshold voltages than TN are those used for high-multiplex operation (Hi-Mux), super twisted nematic (STN) and others.

3.6.1 AC Drive

The LCD has minimal power requirements. From this fact, one might assume that the liquid crystal display is a direct current (DC) operated device. This is not true. The LCD is an alternating current (AC) operated device. If the actual LC cell is operated on DC, it will rapidly fail. If the cell is subjected to DC voltages over 25 mV, the chemical composition of the cell is rapidly changed. These changes are catastrophic and lead to failure of the liquid crystal cell. In some cases, DC drive of the LC cell causes the indium tin oxide (ITO) electrodes to be reduced to indium tin. While indium tin oxide is transparent, indium tin is not. Hence, the AC driving circuitry used should have a zero average dc level.

Electrically, the LC cell can be modeled as a capacitor with both series and parallel resistive elements. Figure 0-12 Electrical model of an LC cell sketches the equivalent electrical schematic of a liquid crystal cell. R_s is the spreading resistance and is very low (less than 1Ω), while R_L is the leaking resistance of the LC cell and is very high (usually over $10 \text{ M}\Omega$). The capacitive element of the LC crystal is around 1000 picofarads.

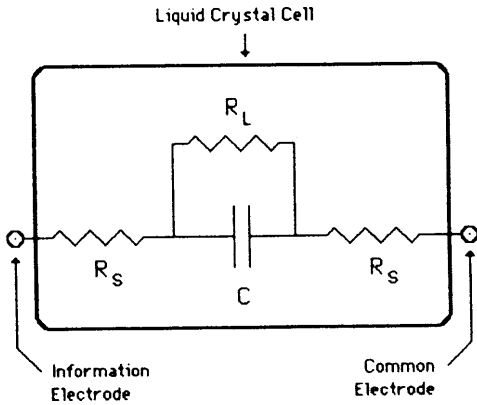

Figure 0-12 Electrical model of an LC cell

The contrast of an LC cell is proportional to the peak voltage across the cell. Three to 10 peak-to-peak AC volts are used by most displays, with a very low DC voltage component. The switching of LC pixel depends on RMS voltage.

There are many techniques used to provide the AC voltage drive that is acceptable to the LCD. The most common scheme uses a 50% duty cycle square wave that is generated by an oscillator.

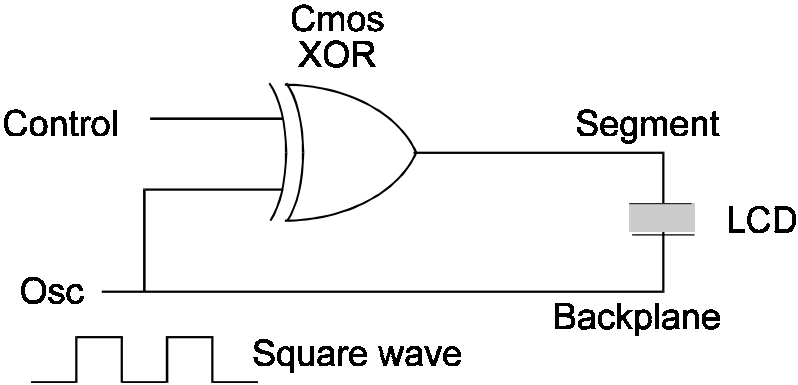

Figure 0-13 LCD driving circuit and the timing waveforms

The square wave voltage is typically between 3 to 15 V_{pp} and the frequency is between 30 to 1000Hz. This signal is applied to the LCD's common or backplane electrode. The same signal is applied to one input of an exclusive OR gate (EX-OR). The EX-OR's output is connected to the information electrode of the LC cell. When the other input to the EX-OR is at logic ground, then the output of the EX-OR gate is identical (in phase) with the common signal provided by the 50% duty cycle square wave oscillator. In this condition, there is no RMS voltage across the LC cell and no information is displayed. If the second input of the EX-OR is brought to logic level high, then the signal out of the EX-OR will be exactly out of phase to the square wave oscillator signal. This will cause a peak ac voltage of 2 times the supply dc voltage to appear across the LC cell. In LCD driver, it is very important to use CMOS electronics to drive LCDs. The ability of CMOS logic to switch very close to ground is necessary to reduce the dc voltage component across the LC cell.

The frequency of the square wave oscillator is critical. If the oscillator is running at less than 30 Hz, then the display will appear to flicker. The power consumption of the LC cell is

directly proportional to the frequency of operation. Operation above 1000 Hz increases the LC cell's power consumption. Most manufacturers recommend running their displays between 32 Hz and 60 Hz.

3.6.2 Direct Drive

Used in watch and calculators. The direct drive LCD has a discrete set of electrodes for each and every LC element within the display. This works fine for small and relatively uncomplicated displays, typically up to 30 - 40 segments (e.g. 4 x 7-segment digits), but becomes cumbersome in larger, denser displays.

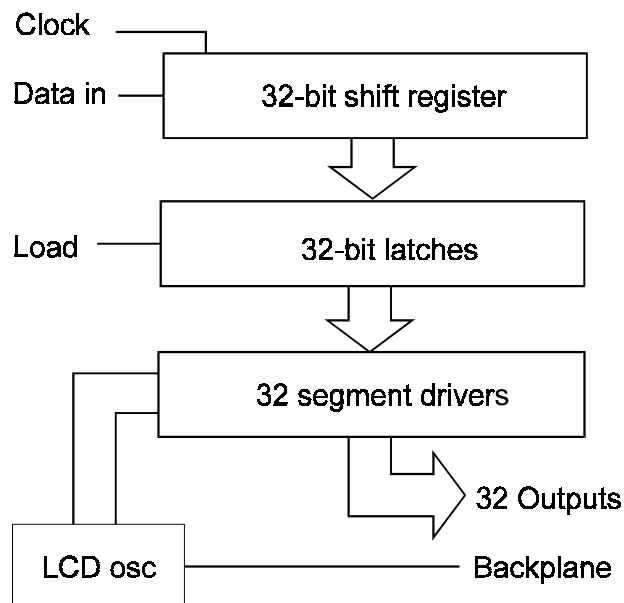

Figure 0-14 Direct Drive circuit

3.6.3 Multiplex Drive

Direct drive method requires one connection per signal. When the display begins to have hundreds of elements or more, then a multiplexing technique is required. Multiplexing is basically a hardware time sharing technique.

The necessity of providing an AC drive waveform greatly complicates the multiplexing of liquid crystal displays. The advantages of multiplexing, however, do outweigh its disadvantages. If an LCD contains a large number of elements, then the simplification of its external electrical connections alone justifies the additional complexity of multiplexing the display. In multiplexing, the individual LC cells' electrical terminals are arranged on an X-Y matrix. In the case of LCDs, the X axis is called the "common plane", while the Y axis is called the "segment plane."

The main disadvantage of multiplexing is the slow response time (use *rms multiplexing*). One practical limitation in the dimension of the matrix in all currently manufactured multiplexed LCDs is limited to no more than 16. This is due to the contrast to voltage response (contrast depends on difference in rms on / off voltages), and speed limitations, inherent in liquid crystal use. Any greater multiplexing results in poor contrast and reduced readability.

Multiplexing is suitable for displays which require long response time, 30-150 ms. Numeric displays for watches, calculators use 2:1 *diplex*, 3:1 *triplex*, 4:1 *quadriplex* multiplexing rates.

3.6.4 Active Matrix Displays

Multiplex service for LCDs requires complex electronic drive schemes as discussed above. These electronics significantly increase the power consumption of a display type which is mainly selected for its low power consumption and portability. Multiplex service requires that the LCD be of very high quality in order to work with lower ac drive voltages.

The ultimate preferred solution for large area, high information content, colour, grey-scale display applications is the active-matrix (AM) LC approach which eliminates the multiplexing problem. A comparison in performance between AM LC cells and simple multiplexed LC cells is shown in Table 0-1 Comparison between AM and simple multiplexed STN:

Table 0-1 Comparison between AM and simple multiplexed STN:

	Active Matrix	Multiplexed STN
LC mode	TN	STN
Contrast ratio	100:1	15:1
Viewing angle	H: $\pm 60^\circ$, V: $\pm 45^\circ$	H: $\pm 30^\circ$, V: $\pm 25^\circ$
Response time	30 - 50 ms	150 ms
Multiplexed lines	>1000	~400
Grey scale	>16	8

Others technologies that had been tried for active matrix displays are:

Metal-Insulator-Metal (MIM) LCD

Diode LC

3.6.4.1 TFT Active Matrix Displays

Figure 0-15 An electrical schematic of a TFT LC cell. is an electrical schematic of a TFT LC cell. A Thin Film Transistor (TFT) is added to each display pixel in large displays. An amorphous silicon (a-Si), polysilicon (p-Si) or silicon-on-sapphire (SOS) transistor fabricated using semiconductor technology directly on glass substrate. TFT provides direct drive for each pixel.

The TFT junction can be considered as a flip-flop. It will hold the LC cell in either an on or an off state until it is changed by the control circuitry. This gives the display a defacto memory and solves many problems with addressing and refreshing large, hi-res, displays. The flip flop type of memory also saves the central video processor the chore of continually updating unchanged pixels.

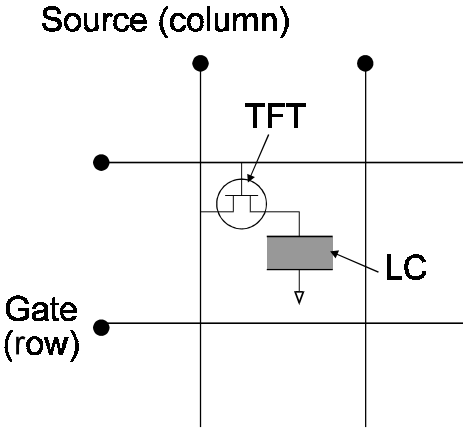

Figure 0-15 An electrical schematic of a TFT LC cell.

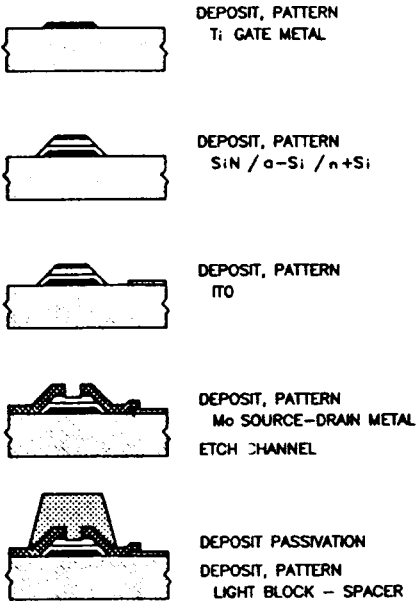

Figure 0-16 Fabrication of a a-Si TFT array

The TFT junctions that drive the LC cell are very small and consume very little power. A typical unit will have a current drain of less than 0.1 μ A at 5 V DC. Even in LCDs with very small pixels, the TFT is still minuscule and occupies less than 2% of the LC cell's surface area. Figure 0-17 A TFT LC array illustrates the physical construction of a typical TFT LC cell's backplane. Each pixel has one TFT and a capacitor, formed by electrodes and LC. The gate of a TFT connected to row scan; the source connect to column drive and drain connected to LC capacitor. Figure 0-18 shows a cross section of a TFT LCD.

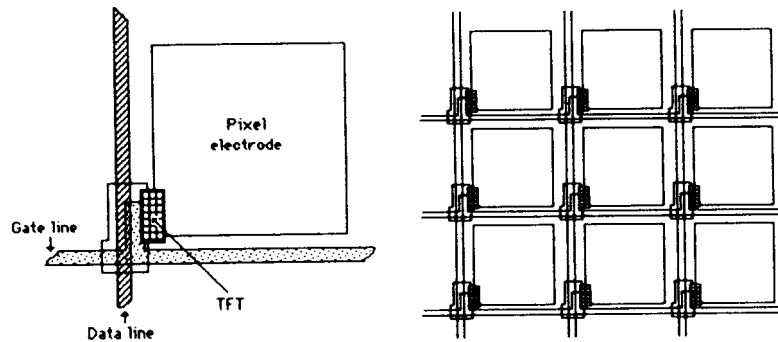

Figure 0-17 A TFT LC array

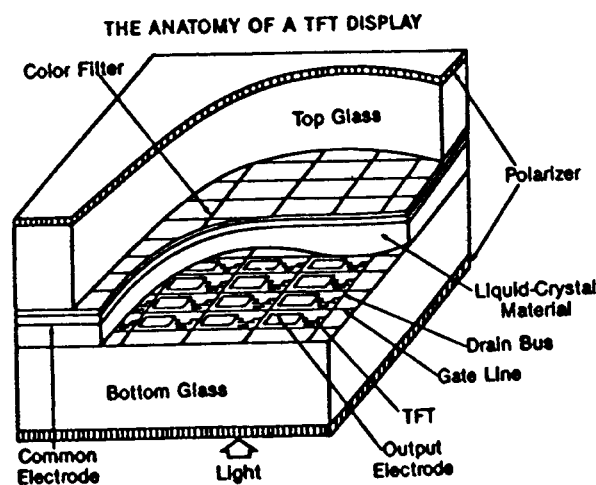

Figure 0-18 A cross section of a TFT LCD

The TFT transistors that control this type of LC display can be driven in linear mode. This means that the transistor junctions can be turned partially on and not necessarily saturated. This allows the TFT LCD to be partially activated and to display a wide range of grey tones.

3.6.4.2 Scanning of Active Matrix

Each pixel element has one TFT and a LC capacitor formed between the indium tin oxide (ITO) transparent output electrode on the TFT matrix circuit and the ITO back plane electrode on the color filter with the LC layer as the insulator. To operate the TFT-LC cell, a one-line-at-a-time addressing method is used. When a row (scan or gate line) is addressed, a positive pulse of width (τ) is applied to the line turning on all TFT's along the row. The TFT's act as switches transferring charges to LC capacitors from the respective columns (source or data lines). When other rows are addressed, a negative voltage is applied to the gate line turning OFF the TFT's along the line and holding the charges in the LC capacitors for one frame time until the line is addressed again. If the LC used in the cell is twisted nematic (TN), it is desirable to use AC voltage to drive the LC element. The polarity of the data voltage switches in alternate frames (as shown in Figure 0-19 The driving waveforms of both the gate and source lines.). When the LC capacitor is charged and the TFT turned off, the charge will remain in that state till next cycle. Hence each pixel is direct driven. Good contrast and viewing angle have been achieved for the TFT LCDs.

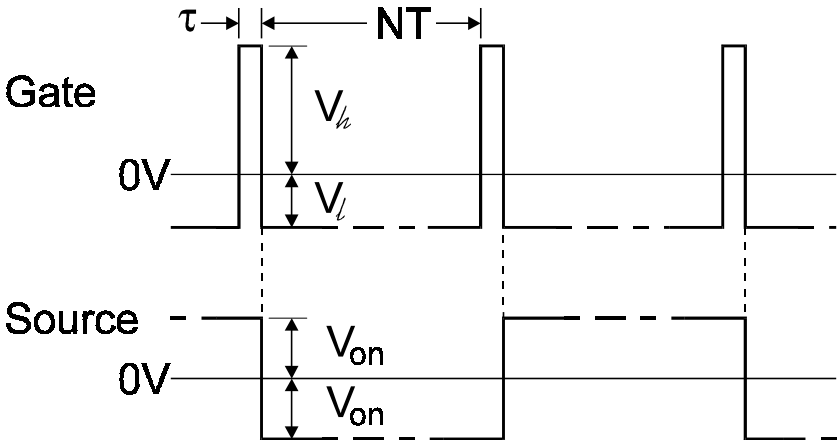

Figure 0-19 The driving waveforms of both the gate and source lines.

Complete LCD modules with display, backlight, controller and drivers are manufactured so that standard VGA chips can drive them like CRT displays.

For a bi-level display such as an alphanumeric or graphic display, the requirement on the pixel voltage is not very tight since all voltage above the ON voltage of the LC element will be acceptable.

For a display with a 16ms frame time, the RC time constant should be longer than 160ms. The OFF currents of the TFT's should be low so the charges stored in the LC capacitors will not leak away to affect the appearance of the panel.

In order to reduce the severe requirements on the TFT OFF currents and the LC RC time constant, a storage capacitor can be added to each pixel element. The storage capacitor can be either a general ground capacitor or a capacitor formed between the ITO output electrode and the following scan line. The trade-off of these storage capacitor designs is the increased fabrication complexity and reduced yield. For displays with moderate and low resolution (<200 lines per inch) the storage capacitor is desirable but maybe not required. For high resolution displays (>500 lines per inch), the storage capacitor is considered to be a necessity.

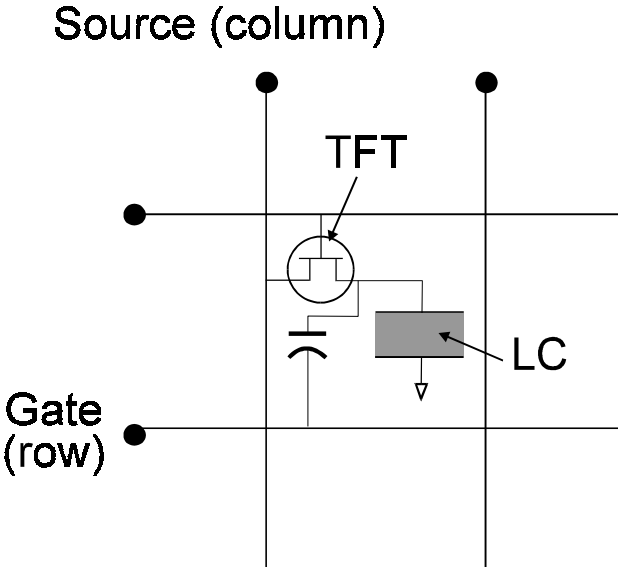

Figure 0-20 AM cell with added capacitor

Table 0-2 Comparison of various AM technologies

Technology	Device Size (μm) W X L	Drive Current	leakage Current
a-Si Diode	20 X 20	10^{-4} A	10^{-14} A
a-Si TFT	15 X 4	10^{-6} A	10^{-13} A
p-Si TFT	10 X 30	10^{-6} A	10^{-12} A
SOS TFT	10 X 30	10^{-5} A	10^{-10} A

An example of a Colour LCD specification.

Specifications: (Hitachi 10.4 in)

View area:	210 x 158 mm
Pixels:	640 x 480
Colour filter:	vertical RGB stripes
Display mode:	Normally white
Colours:	512, 4096
Contrast ratio:	80:1
View angle:	H: $\pm 35^\circ$ V: $+15^\circ, -40^\circ$
Response time:	t_{on} : 35 ms / t_{off} : 20 ms

3.7 Updates: Poly Si (Silicate) LCD (Liquid Crystal Display)

Poly-Si is typically 3 separate layers of liquid crystal displays, one each for red, green and blue. This results in increased colour dynamics, with contract ratios around 200:1. Poly-Si technology is also a bit faster than the active matrix TFT and is good for smooth video and multimedia.

3.8 Other Application of LCD

Projection devices:

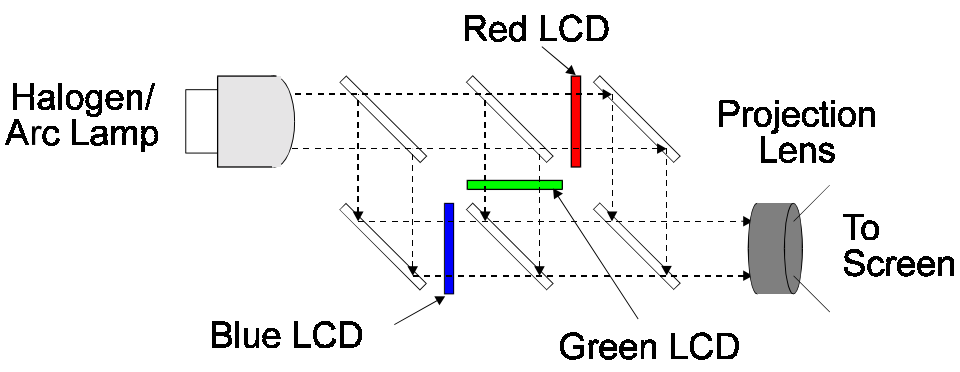

3.9 Introduction to Plasma

The plasma display is a flat panel, light producing, gas discharge display. The plasma panels are attempting to do the same job as the CRT-visual electronic display of text and graphics information. Modern plasma panels are now making inroads into the computer display market.

The physics behind the operation of the plasma panel is very basic. The principle is the same as the common, everyday, neon sign- neon gas emits light when electrical current is passed through it. As in the case of most display technologies, the actual physical principles underlying the display's operation are simple. It is the actual implementation into a hi-resolution, mass produced, operating display that is very complex.

Plasma displays are currently competing with other technologies for the lucrative military and industrial display market. The flat profile of the plasma panel fits into tight spaces such as military vehicles. This market is able to bear the additional cost of plasma panels in relation to CRTs.

3.10 HOW PLASMA DISPLAYS WORK

The plasma panel is a super complex collection of neon lights. Plasma is an ionized and electrically conductive gas. The principle of its operation was discovered when physicists noticed that some gases glowed under electronic flow. The intensity and color of the light depended on the gas being used, its pressure, and the amount of electrical current flow through it.

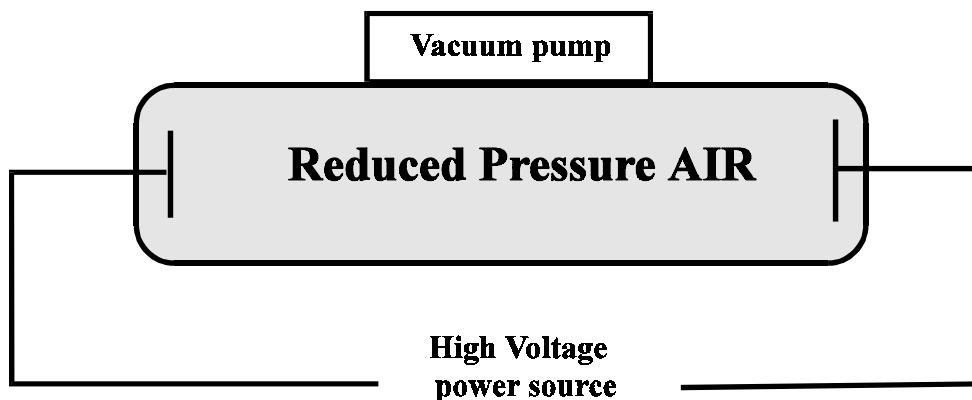

Figure 0-21 Gas discharge tube

Figure 0-21 Gas discharge tube shows gas discharge tube. The physicists noticed that if the gas was partially evacuated from the tube, then a purplish-pink light was emitted by the gas when the electrodes were charged with high voltage. The air would not glow at higher or lower gas pressures. The gas pressure within the tube is an indication of the density of the gas within the tube. If there are too many gas molecules per unit volume within the tube, the electric field within the tube will not cause the gas to glow. The situation is similar if there are too few gas molecules per unit volume in the tube. The reason for this is found in the physics of the energy transfer between the electrons moving through the tube and the electronic structure of the gas molecules.

As the electrons move through the gas, they ionize the individual gas molecules. The gas molecule, while ionized, rearranges its electronic configuration and dissociates into a positive gas ion and an electron(s). This rearrangement is not an electrically stable electron configuration and rapidly decays to a more stable form. Decay, in this case, means that a gas ion absorbs one (or more) of the free electrons. During this decay process, some of the energy gained from ionization is radiated as a visible photon(s).

The voltage potential at which the gas becomes a plasma and conducts electricity is called its "breakdown" voltage (typically 100 to 200 V). This breakdown voltage varies with the chemical composition of the gas, and with the pressure of the gas. Plasma displays commonly use gases in the inert gas (noble) family, usually neon, argon, and xenon. The actual gas in the plasma display is often a mixture of these noble gases. Small amounts of other "dopant" gases are sometimes added to the noble gas mixture to obtain variations in color.

Plasma displays are currently made in two forms- DC plasma and AC plasma displays.

3.10.1 DC Plasma display

The most basic type is called dc plasma. Figure 0-22 shows an DC plasma cell schematics. The anode can be made from a transparent oxide coating on the front surface of the display, as shown in the figure, or from a wire mesh next to the glass. When a voltage above the ionization threshold is applied between the anode and a selected cathode, the gas between the two ionizes. The anodes can be arranged as segments to form a segmented numeric or alphanumeric display. In the DC plasma cell, the gas is in direct electrical contact with the electrodes of the cell. The DC plasma display has no inherent pixel memory and is refreshed much in the same manner as CRTs.

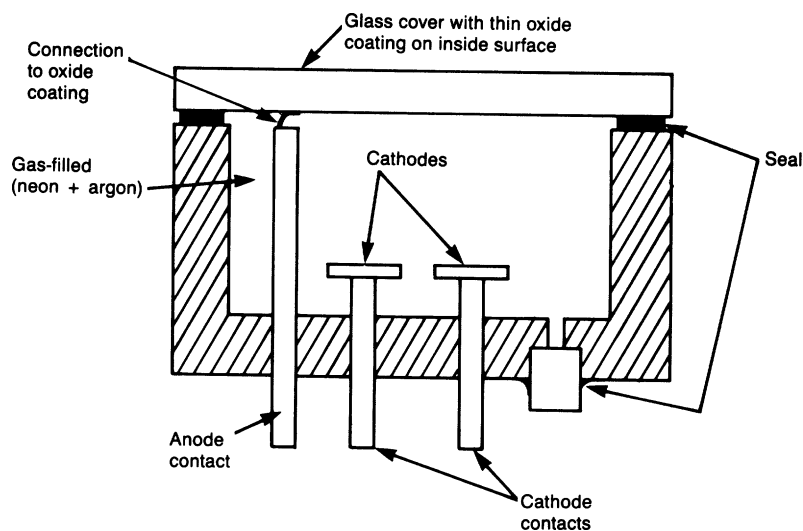

Figure 0-22 Basic gas discharge display configuration

Most DC plasma displays are dot matrix. The cathode is divided into stripes in one direction, and the anodes are stripes in the perpendicular direction. The display is then driven in a multiplexed fashion by driving one cathode at a time. By controlling the anode voltages, dots are formed at the desired intersections. The display size that can be produced by this technique is limited because as the display size increases, each dot is on for a shorter period of time. Thus, the brightness decreases as display complexity increases. This type of display also requires one

driver for each row and each column. Unlike LCD displays, the drivers must be able to switch high voltages, which makes them expensive.

The main factors affecting speed in larger panels are the configuration of the matrix and the method used to apply the information to the matrix. In large plasma displays the matrices are often subdivided into a number of smaller and more quickly managed sub-matrices. The more the entire matrix is subdivided, the smaller each sub-matrix becomes, and the faster the overall display can be operated.

3.10.2 AC Plasma display

The ac plasma panel operates on AC electricity. The only physical difference between the two types is the absence of the dielectric, insulative layers separating the electrode from the gas mixture in the AC plasma cell. While the physical principles used in both AC and DC plasma panels are very similar, their operation and implementation are very different. In AC plasma displays, a dielectric is added between the electrodes and the gas, effectively forming a capacitor. Thus, an AC field is required to cause the gas to ionize. A continuous AC voltage that is just below the threshold required to ionize the gas is applied to all the electrodes. By applying an additional voltage pulse to an individual anode/cathode pair, the gas is ionized. The continuous AC voltage is sufficient to keep this gas ionized, so the cell stays on after the pulse ends; the display has inherent built-in limited memory. This pixel memory is the prime advantage of the AC plasma cell over the DC type. The display therefore does not require refresh, and a separate refresh memory is not required as with other multiplexed displays. However, the drive circuitry is complex and must control high voltages, resulting in a relatively expensive display.

3.10.3 Memory in AC Plasma

The AC type of plasma panel offers a limited form of cell memory. In the case of the plasma panel, this does not mean that once a pixel is fired that it will stay lit. It means that the ac pixel can be immediately reactivated by supplying less energy than it initially required to fire. This effect is due to the ac panel's additional insulative layers within the cell, and is generated by the ac plasma cell's capacitive nature.

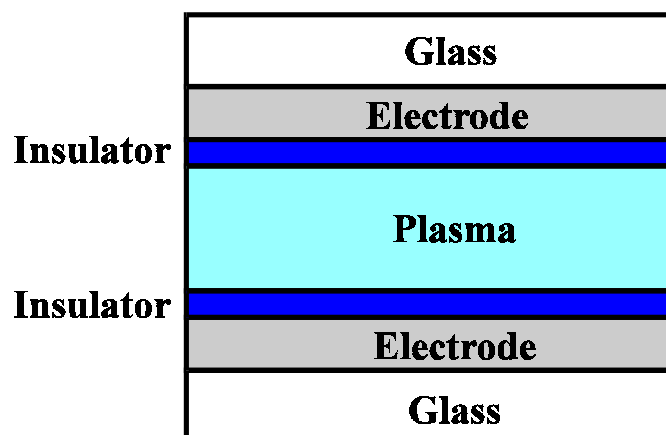

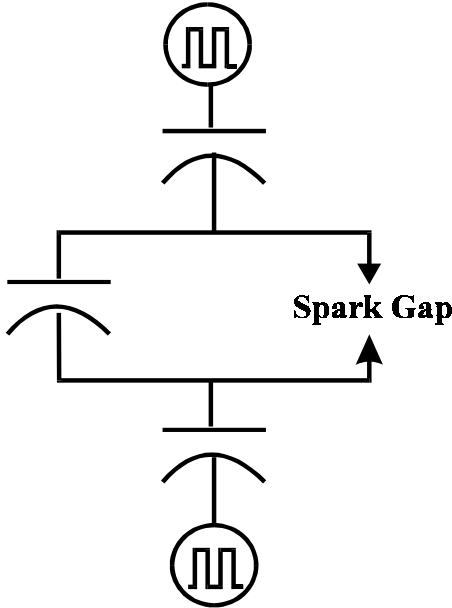

Figure 0-23 Electrical model of AC plasma

The AC plasma cell can be represented electrically by a series string of three capacitors and a spark gap, see Figure 0-23 Electrical model of AC plasma. The capacitance of the gas layer is low in comparison with the capacitance of the insulative layers. When the cell is firing, the voltage drop across the gas layer is much greater than the voltage drop across the insulative layers. This inequality between the potentials within the cell causes ions to collect on the inner surfaces of the dielectric layers. This "wall charge" allows the cell to be immediately refired with about half the voltage required to initially fire the cell. Figure 0-24 AC plasma cell memory effect illustrates this process schematically. Section (a) of this illustration shows the initial firing of the cell. Section (b) shows the charges collecting on the walls of the ac cell. Section (c) illustrates the usage of this wall charge to refire the cell with a lower voltage.

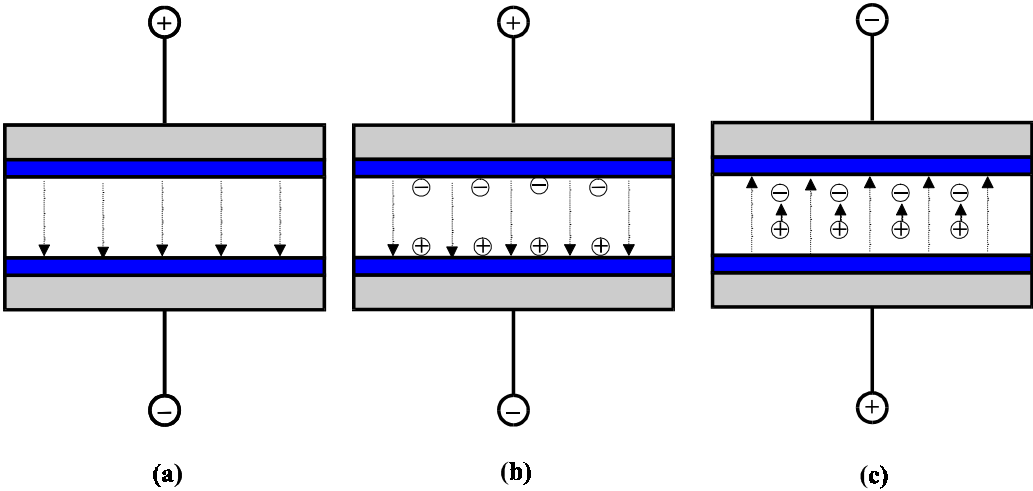

Figure 0-24 AC plasma cell memory effect

The wall charge of the cell rapidly dissipates if the cell is not refired. In order to take advantage of the wall charge, the AC cell must be refired by the sustaining signal within approximately 50 μ s. Sustaining waveforms are commonly used with frequencies around 40 kHz. The use of the sustaining waveform complicates both the information processing and the display's electronic drivers. This technique is only employed in displays with huge numbers of pixels because of the additional complexity and expense. Smaller plasma displays are usually of the dc type because it is easier and cheaper to update the entire screen rather than to implement the AC type's memory.

3.10.4 Power Requirements

The basic plasma pixel needs to have a potential of at least 100 volts before it will fire. The exact amount of voltage required depends on the panel's geometry, the type of gas used, and the gas's pressure. The amount of current flowing through the plasma cell when it fires is very low, between 1 and 10 microamperes. The AC plasma panel dissipates between 1 mW and 2 mW per pixel. The dc coupling and absence of the insulating layers of the dc plasma panel allow its pixels to be fully illuminated at about 0.6 to 1.5 mW per pixel. These figures include operation of the display's logic and on-board inverter power supplies. This level of power consumption is moderate, and is much less than a CRT of the same size.

3.11 The Sony Plasmatron

There are many possible forms of flat-screen display, including the well-established liquid crystal display. An active-matrix system is used in the best LCDs currently available where a matrix of transistors built into the panel is used to switch on each pixel individually. LCDs are small, light and use little power. But they are expensive to manufacture, typically costing around 30-40 per cent of the cost of a notebook computer. Production of large-screen LCDs is particularly difficult, a single bad transistor will result in a faulty display.

Sony has announced a new display technology known as the Phased Addressed Liquid Crystal Display (PALC), or better known as the Plasmatron.

As its name suggest, the PALC display uses a variation on conventional LCD technology. The PALC system uses a plasma discharge instead of a transistor to provide the switching action. Figure 0-25 FET analogy of a plasma cell shows the basic principle. The plasma switch operates like a transistor - its action is in fact akin to that of a field-effect transistor. The anode is the source, the cathode is the gate and an imaginary electrode acts as the drain to activate the LCD cell. The discharge occurs in the low pressured gas when a pulse voltage of around -300V is applied to the cathode. In PALC the discharge is used as a switch.

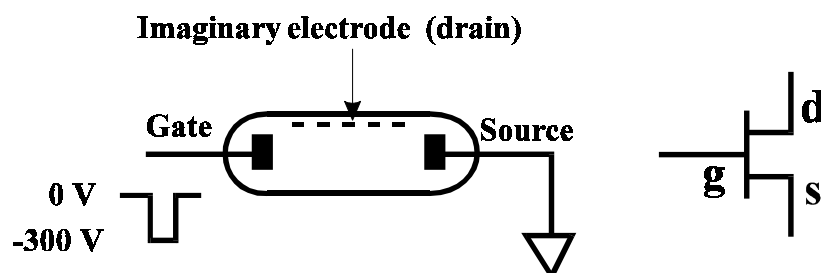

Figure 0-25 FET analogy of a plasma cell

When a drive pulse is applied to the gate, the video signal, which is applied between the imaginary electrode and the source, sets the illumination produced by the LCD section. Figure 0-26 Basic construction of a single pixel cell shows the construction of a pixel cell, a transparent electrode in the LCD section providing the signal connection (imaginary electrode/drain).

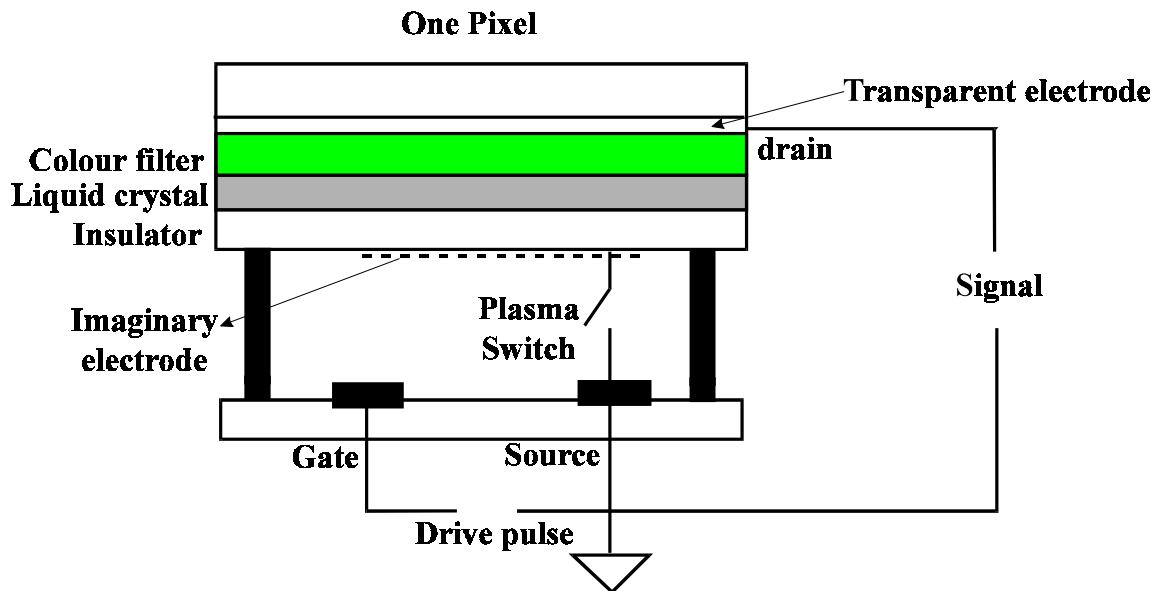

Figure 0-26 Basic construction of a single pixel cell

In a raster display, each scanning line is controlled by a single plasma channel, the whole display having around 450 channels. Similar to Figure 0-26 Basic construction of a single pixel cell, the LCD pixel cell has several layers. These include the transparent electrode, a colour filter, a liquid-crystal layer and an insulating layer. When the discharge pulse is applied to the plasma channel a complete line is switched on and the video signals are applied to the individual pixel cells. Thus signals equivalent to a single CRT display line are fed to the PALC device simultaneously. The plasma channels are switched on sequentially, with each pixel retaining its state until the next frame of video information is fed to the device.

The production cost of a PALC panel is much lower than that of a conventional LCD screen because only low grade clean room are required for the processing involved.

References

M. Slater, *Microprocessor-Based Design*, Prentice-Hall, 1989, pp348-361.

B. Bahadur, *Liquid Crystals, Applications and Uses*, Vol. 1, World Scientific, 1990.

R. Perez, *Electronic Display Devices*, TPR, 1988, Chapter 6 & 9