



SENSORLESS BLDC MOTOR CONTROL AND BEMF SAMPLING METHODS WITH ST7MC

1 INTRODUCTION

Permanent Magnet Brushless DC Motors are replacing brush motors in numerous applications as they offer significant energy efficiency improvements, lower acoustic noise and better reliability to name a few advantages. To be driven and controlled properly, 3-phase Permanent Magnet Brushless motors require a 3 half bridge "inverter" topology to deliver a 6-step or sine wave signal. They also require the electronic commutation of motor phases to respect the synchronization between statoric flux and the permanent magnet of the rotor.

Generally, a BLDC motor drive uses one or more sensors giving positional information to keep synchronization. Such implementation results in a higher drive cost due to sensor wiring and implementation in the motor. Moreover, sensors cannot be used in applications where the rotor is in closed housing and the number of electrical entries must be kept to a minimum such as in a compressor, or in applications where the motor is immersed in a liquid such as some pumps.

Therefore, for cost and technical reasons, the BLDC sensorless drive is an essential capability of a brushless motor controller. The ST7MC allows various implementations of sensorless BLDC control with the lowest possible system cost while maintaining the highest performance. This paper describes in detail these topologies, their advantages and drawbacks, as well as their practical implementation. Most of the examples in this paper make use of the ST7MC-KIT/BLDC Starter kit which allows easy implementation of most topologies described.

Table of Contents

1 INTRODUCTION	1
2 SENSORLESS DRIVE PRINCIPLE	3
2.1 SAMPLING METHOD	6
3 SAMPLING AT END OF PWM OFF STATE (ST PATENTED "3 RESISTOR" METHOD)	7
3.1 DESCRIPTION	7
3.2 ST7MC-KIT/BLDC PRACTICAL IMPLEMENTATION	8
3.3 PRACTICAL RESULTS	9
4 SAMPLING DURING PWM ON STATE (INDUSTRY STANDARD "CLASSICAL" BEMF METHOD)	11
4.1 DESCRIPTION	11
4.2 PRACTICAL IMPLEMENTATION OF SAMPLING DURING PWM ON	13
4.2.1 Components dimensioning	14
4.2.2 Size of Reference Voltage	15
4.2.3 Size of BEMF sensing network	15
4.3 PRACTICAL IMPLEMENTATION OF THE "CLASSICAL" METHOD, USING THE ST7MC-KIT/BLDC STARTER KIT 17	
4.4 PRACTICAL RESULTS	18
5 SAMPLING DURING PWM ON STATE USING DIGITAL FILTER	20
5.1 DESCRIPTION	20
5.2 PRACTICAL IMPLEMENTATION	21
5.2.1 Sizing of network on motor phase	22
5.2.2 Sizing of Network of Voltage Reference	23
5.3 RECORDS OF DIGITAL SAMPLING DURING PWM ON	24
6 MIXED SAMPLING AT END OF PWM OFF AND DURING PWM ON	25
7 BEMF SAMPLING AT HIGH FREQUENCY METHOD (USED IN PULSE AMPLITUDE MODULATION METHOD)	27
8 CHOICE OF SAMPLING METHOD	27
9 CONCLUSION	28
10 APPENDIX - IMPROVED BEMF DETECTION FOR LOW SPEED AND LOW VOLTAGE APPLICATIONS	29
10.1 THEORY	29
10.2 PROBLEMS	30
10.2.1 Solution	31
10.3 RESULT	32
10.4 CONCLUSION	33
11 REVISION HISTORY	34

2 SENSORLESS DRIVE PRINCIPLE

The sensorless drive is based on the detection of the Back Electro Magnetic Force (BEMF) induced by the movement of a permanent magnet rotor in front of stator winding.

This method also requires the use of a trapezoidal signal in order to have a zero crossing of the BEMF.

Figure 2 below shows the three BEMF voltages referenced to the neutral point for a motor running at constant speed without excitation (the motor is not supplied, and the rotor is manually rotated).

Figure 1. Model of BLDC Motor with the Wire in Star Connection.

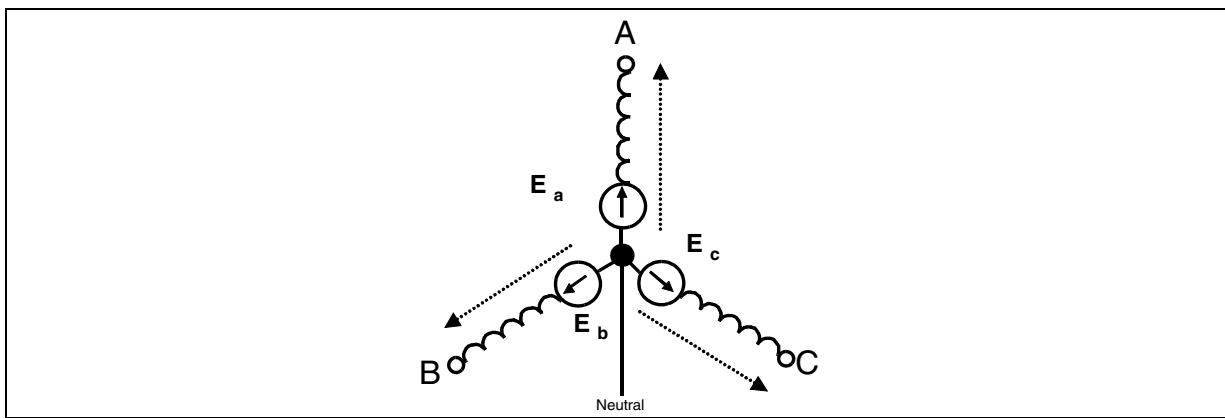
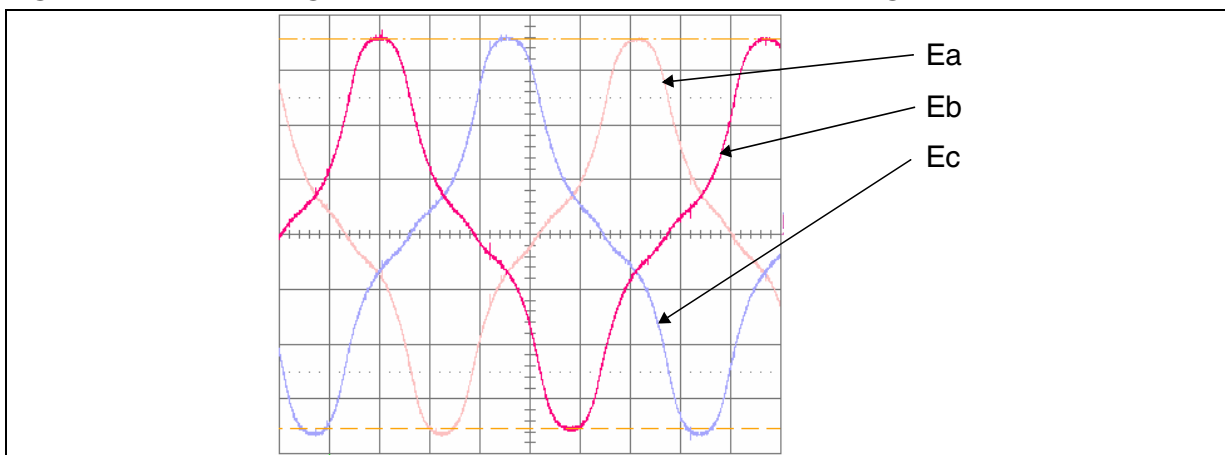

Figure 2. Phase voltage versus Neutral For each stator winding



For a given fixed motor design (number of stator winding turns, mechanical rotor characteristics and rotor magnet characteristics) the BEMF Amplitude is proportional to the rotor speed.

The sensorless method uses the zero crossing of BEMF to synchronize phase commutations. To detect BEMF the specific 120° six-step drive is used. "120° six-step drive" forces zero current twice in each phase during a six step period. This allows BEMF zero crossing to be detected and read.

The step sequence and corresponding motor phase current are shown in [Figure 3](#) and [Figure 4](#) below.

Figure 3. Six-Step current circulation

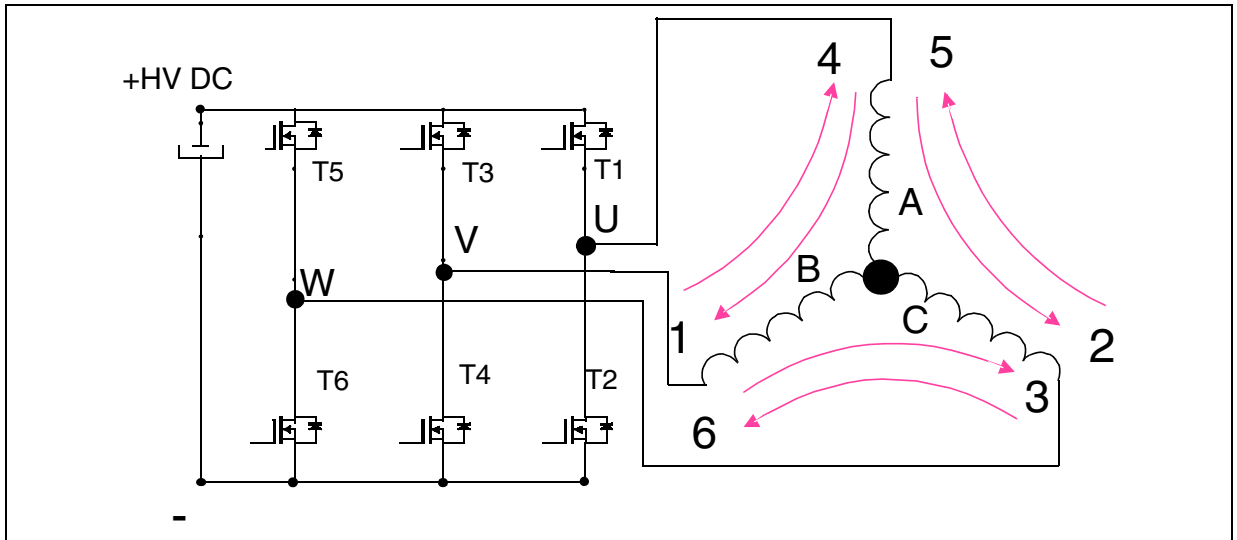
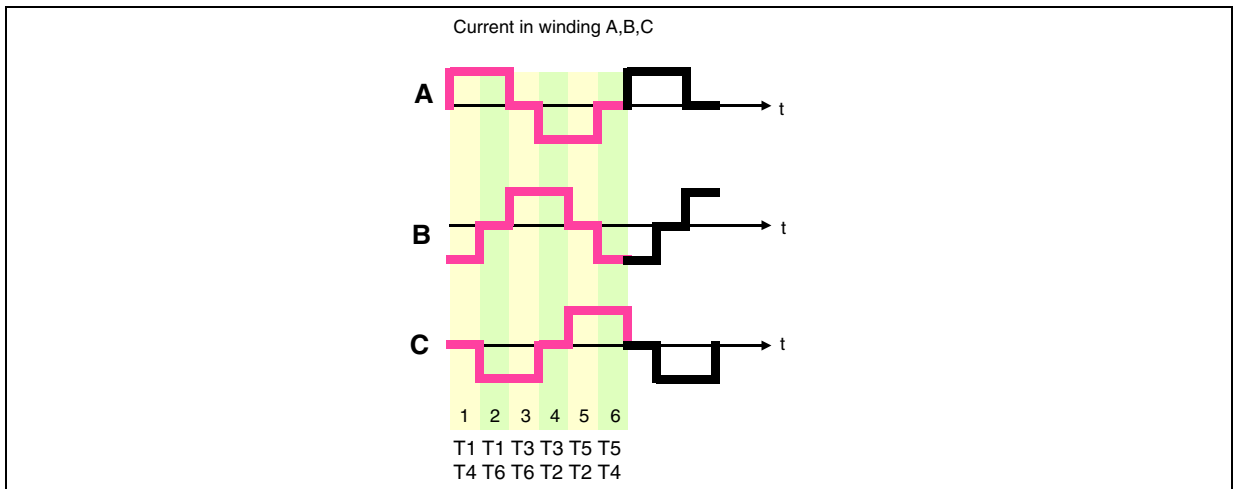

Figure 4. Six-Step sequence



More specifically, for each step, one phase of the motor is not energized, which allows detection of the BEMF zero crossing in this phase.

For each phase two zero crossings must be detected during a period:

- One "rising crossing" when BEMF passes from negative to positive,
- One "falling crossing" when BEMF passes from positive to negative.

In the non-energized winding (phase C here), the current is zero and the voltage measured is the BEMF of the motor ([Figure 5](#)).

Figure 5. BEMF measurement synoptic.

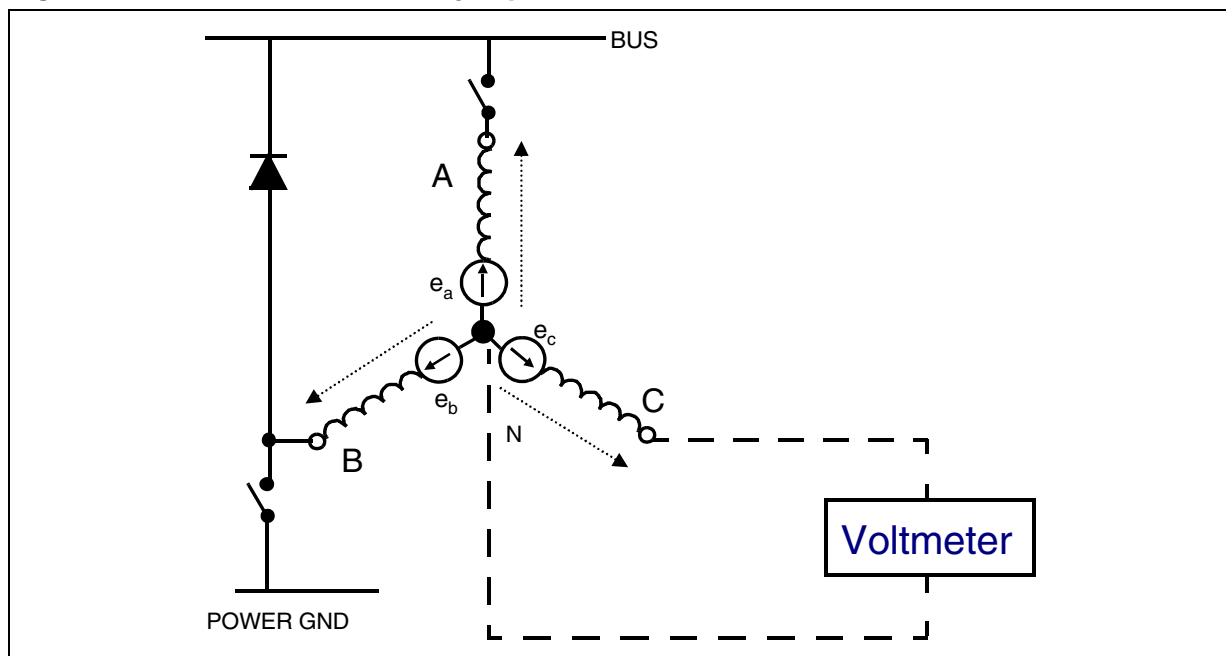

Based on the above BEMF detection principle, several methods are available to precisely determine the BEMF zero crossing point. All these methods have advantages and drawbacks which will be discussed in the next section. These methods also take into account the fact that in most cases the neutral point of the motor is not accessible; either because the motor is delta-wound, or because no wire is extracted. In any case the methods presented in the next section allow the designer to select the most suitable approach to meet his application requirements.

Note 1: Because BEMF is proportional to the rotor speed, this implies that the rotor should turn at a minimum speed to generate sufficient BEMF. This minimum speed varies from one motor to another. For very low speeds it may be required to amplify BEMF in order to control the motor. This is presented in the appendix of this application note.

Note 2: As mentioned above, the sensorless BEMF methods described can only be implemented using a trapezoidal signal drive. A sine wave signal drive doesn't provide zero crossing signals and cannot be implemented with the topologies shown above. It is to be noted however that motors originally designed to be driven with a sine wave signal (these motors are wound in such way that the stator flux has a continuous variation contrary to BLDC wound motors which have non-continuous stator flux commutation) can be controlled with a trapezoidal signal drive and ST7MC, without any impact on performance.

2.1 SAMPLING METHOD

The ST7MC microcontroller allows the implementation of four methods to sample and detect BEMF zero crossing to run a BLDC motor in sensorless mode.

Sampling during PWM OFF State at PWM frequency (SPLG=0 & DS[3:0]=0)

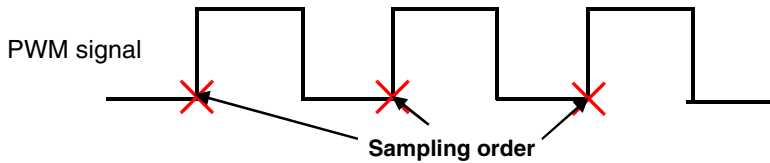

Sampling during PWM ON state only at PWM frequency (SPLG=0 & DS[3:0]=xxx)

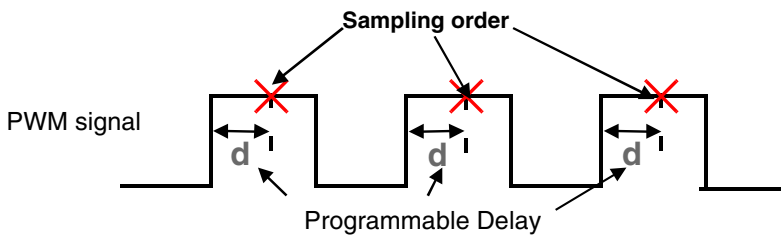

Sampling during PWM ON state only at High frequency (SPLG=1 & DS[3:0]=xxx)

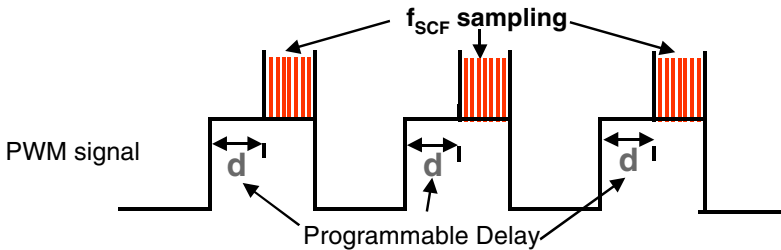

Sampling either during OFF or ON state at High frequency (SPLG=1 & DS[3:0]=0)

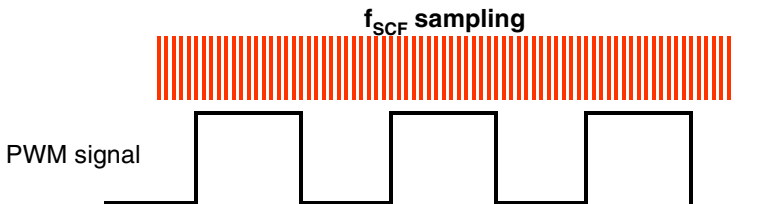

These allow for various controls and hardware topologies to be implemented.

Each method is presented below with benefits, drawbacks and rules to select the right method for a given motor/application.

3 SAMPLING AT END OF PWM OFF STATE (ST PATENTED "3 RESISTOR" METHOD)

3.1 DESCRIPTION

BEMF sampling is fully digital based on the PWM duty cycle. Figure 6 below gives the physical configuration of a motor when PWM is in an OFF state allowing BEMF to be measured during the non-energized phase.

Figure 6. BEMF sampling at end of PWM OFF

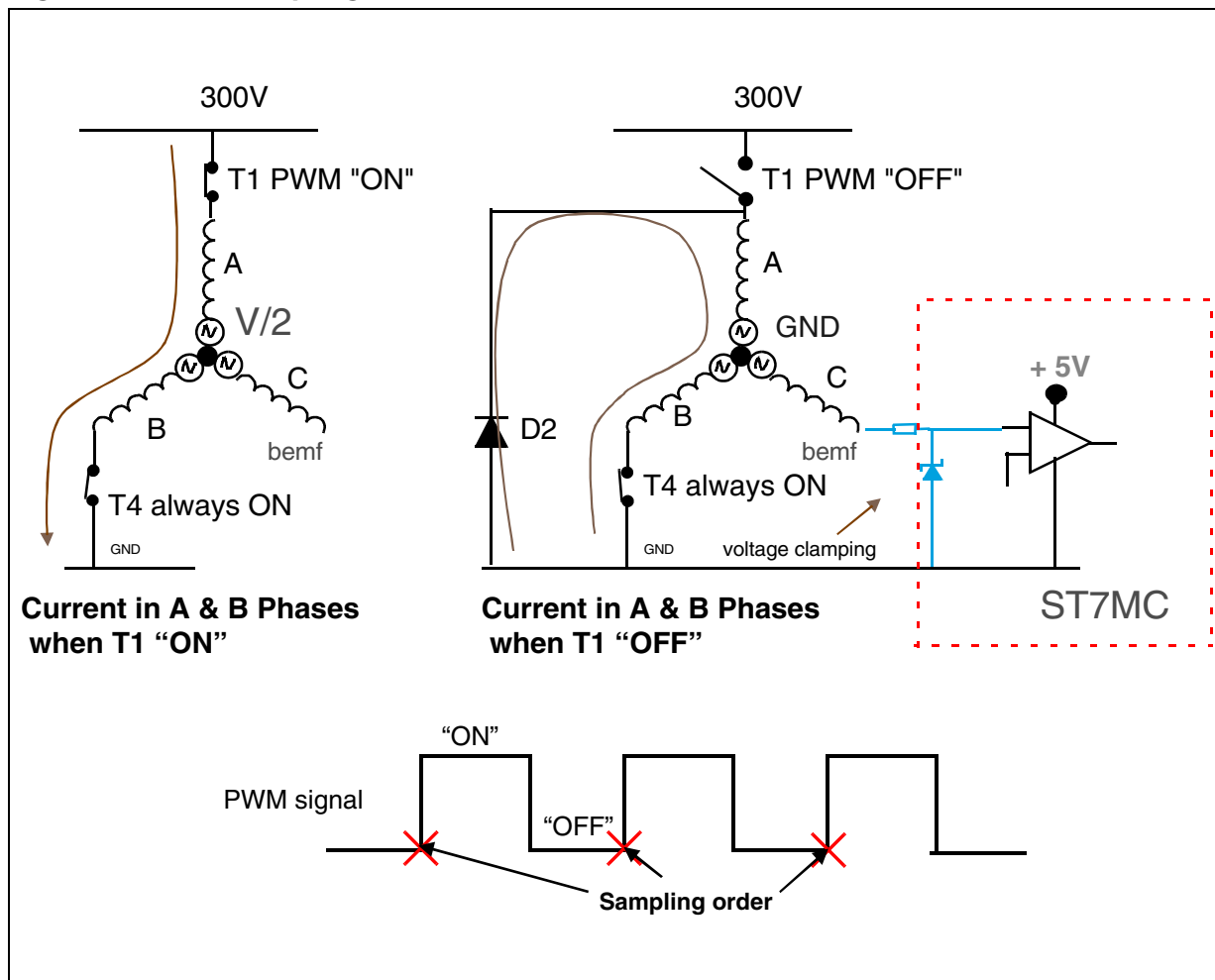

During the Off state of PWM, the current circulation in active winding of the motor passes through D2, the adjacent diode of switch T1.

Due to the fact that the potential of the neutral point is grounded, the voltage comparator obtains complete information about the BEMF voltage of the non-energized phase on its input via C. Application Note AN1130 gives more information about this sampling method.

Advantages:

To sample the BEMF of the BLDC motor, the ST patented method needs only three resistors (to limit input current in I/O) as external components. This simplifies the practical implementation which consists of connecting the three resistors from the three motor phases to the MCIA, MCIB, and MCIC Microcontroller inputs which:

- allows the whole sensing signal for the BEMF to be obtained,
- gives high sensitivity, used to:
 - Get a large speed range on the drive motor,
 - Run the motor at very low speed,
 - Start the motor with maximum torque
- avoids the need for an analog filter, which suppresses filtering delays
- provides high signal to noise ratio

Drawback:

A minimum PWM OFF time is needed and the maximum available duty cycle should be limited.

For some applications we need to go up to maximum (100%) duty cycle, this cannot be reached with the ST detection method and we have to switch to the classical detection method which is described later.

3.2 ST7MC-KIT/BLDC PRACTICAL IMPLEMENTATION

By default the ST7MC-Kit/BLDC starter kit board is configured to use the ST patented "3 resistors" method.

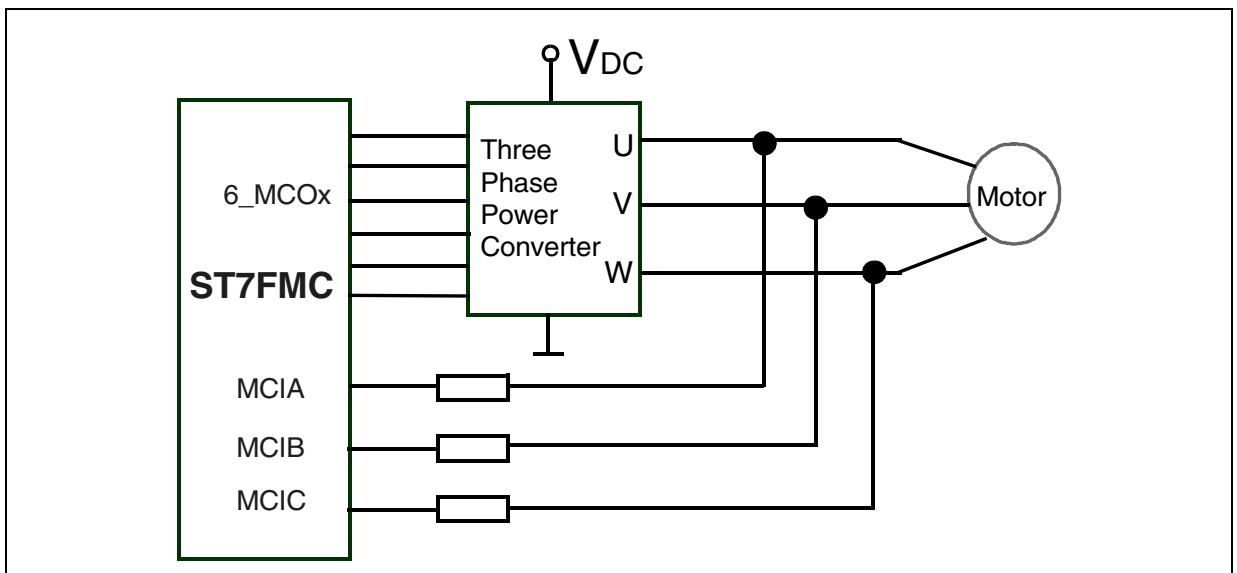
Figure 7. Sampling at end of PWM off implementation

The implemented resistors are used to limit the input current in the pad diode which clamps the voltage on MCIA, MCIB and MCIC microcontroller inputs.

The current in the clamping diode should not exceed 5mA and should typically be around 2mA.

For a high voltage (400V) DC bus, 200k resistors are to be used. For safety and power dissipation, two 100k resistors in serial are implemented on each phase.

Resistors implemented on the starter kit board are two 82k which is suitable both for the 24V motor included and also for high voltage motors.

3.3 PRACTICAL RESULTS

The sampling below ([Figure 8](#)) shows the voltage signal on one phase of the motor drive in 6-step mode.

During both steps where the phase is not energized, corresponding to the floating state of the winding, we can follow the progression of BEMF:

For the "rising transition" between T1 & T2 where BEMF passes from a negative to positive value;

For the "falling transition" between T4 & T5 where BEMF passes from a positive to negative value.

We can note the PWM superposition with the BEMF signal for both "ON" and "OFF" states of the PWM.

For compare values set to zero, we get the zero crossing information only when the PWM is in an "OFF" state.

Figure 8. Sampling at end of PWM "OFF" state

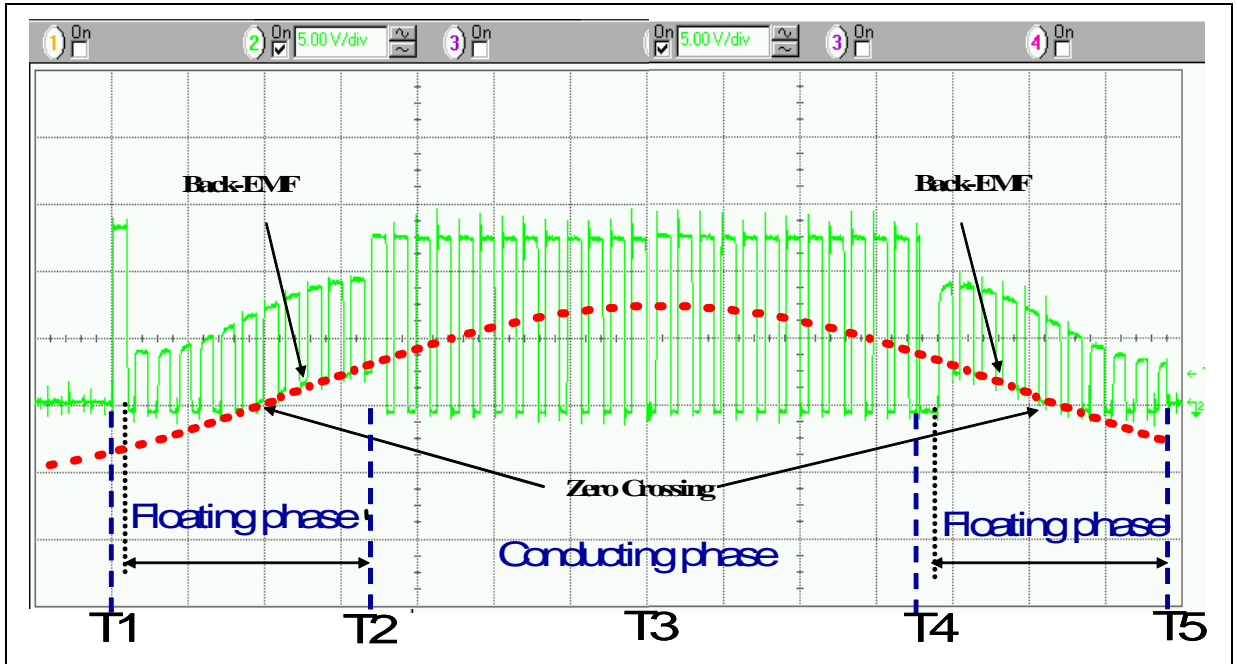

The zero crossing detection can also be done when PWM is in an "ON" state if the compare value is set to the half value of the DC bus. This sampling method is discussed in further detail later.

The fact that a 100% PWM duty cycle cannot be achieved with this method may be a drawback when the motor needs to be used to the limit of its capabilities.

The main advantage of the "3 resistors method" is that, being fully digital it allows maximum efficiency over a very wide speed range, typically 1 to 100.

Finally, the key advantage of this method is its cost which is the lowest available on the market now.

4 SAMPLING DURING PWM ON STATE (INDUSTRY STANDARD “CLASSICAL” BEMF METHOD)

4.1 DESCRIPTION

In this configuration, due to sampling during PWM "ON" state, the neutral point is not grounded like in the previous method.

Figure 9. Sampling during PWM “ON” State Once

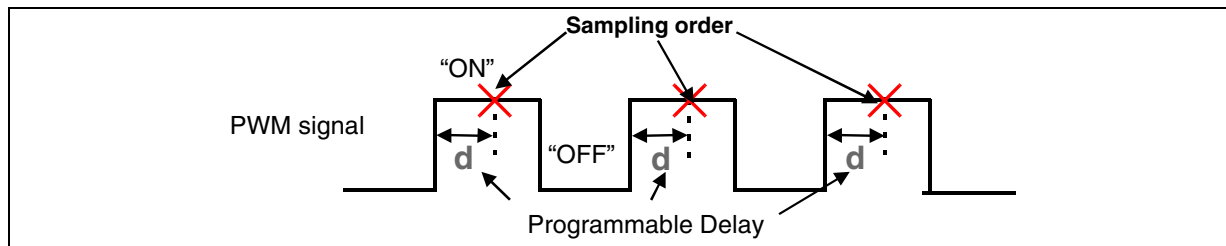

We have to get an access to this neutral point to be able to measure the BEMF voltage.

In many applications like compressor drives, it is not possible to implement a wire giving access to a neutral point. To get this voltage information we use various methods to rebuild a virtual neutral.

We can already note that both sampling methods during PWM ON (sample at PWM frequency or sample at high frequency) can be implemented using:

- Discrete frozen analog filter build with resistor and capacitor, or
- Embedded digital filter of ST7MC.

The zero crossing of the BEMF measurement is done using an analog filter.

With this classical analog method the BEMF is detected through two networks.

One network is used to sense the BEMF on the floating phase and allow passing from a high voltage level to a low voltage level compatible with the comparator input. The switching of the PWM signal gets on the voltage adaptation request to be filter.

A second network allows the voltage reference of floating phase to be obtained necessary to do the BEMF detection.

This second network could be realized following three schemas:

- a) The rebuild of the virtual neutral motor using three resistors and again a voltage divider and filter.
- b) A voltage divider of High DC bus Voltage to get a reference voltage compatible with the input voltage of the comparator (2.5V for example) and which follows the DC bus fluctuation.
- c) In the event of constant DC bus without fluctuation, this second network can be removed and be replaced by the internal reference voltage of the microcontroller comparator.

Figure 10 gives the implementation of the classical method using a voltage divider and filter.

Figure 10. Implementation of the Classical Method using a Voltage Divider and Filter

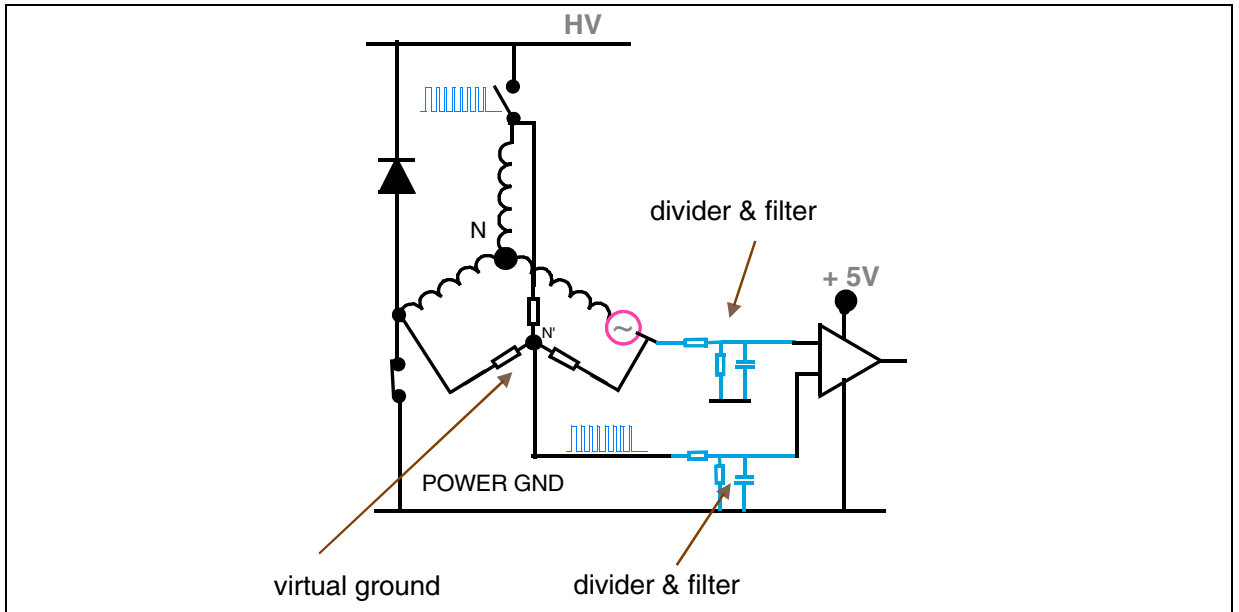

In the implementation using the Classical method, where for the observed phase we used a voltage divider and filter, the reference voltage used can be either:

- The High Voltage DC bus, or
- The internal comparator Microcontroller reference as show in Figure 11.

Figure 11. Voltage reference on HV Bus or Internal voltage reference

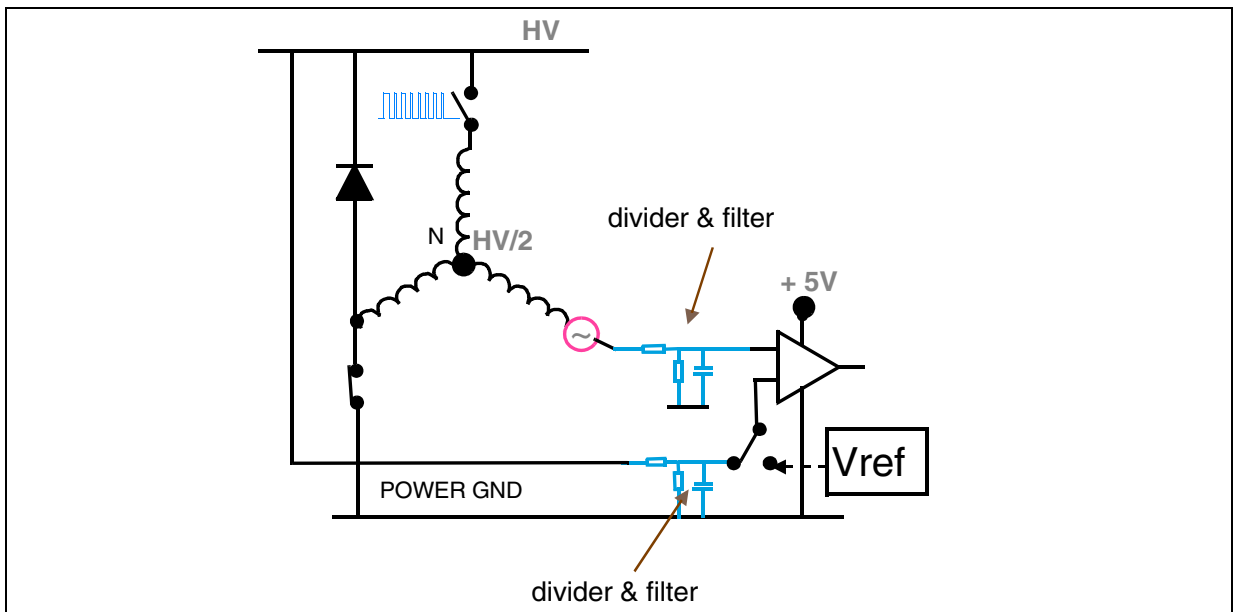

Advantages

With the classical method, BEMF sampling is done during the PWM “ON” state allowing up to a maximum PWM duty cycle (100%).

Drawbacks

Due to the voltage divider being used to sense BEMF, this method is less sensitive than the ST method. This sampling method is dependent on the motor speed because the different networks are influenced by BEMF levels and components are to be dimensioned according to the nominal operation point of the motor.

4.2 PRACTICAL IMPLEMENTATION OF SAMPLING DURING PWM ON

The starter kit board is delivered with a daughter board allowing classical sampling method use.

Figure 12 gives an example of network use to implement the classical method with an analog filter.

Figure 12. Classical method of implementation with daughter board.

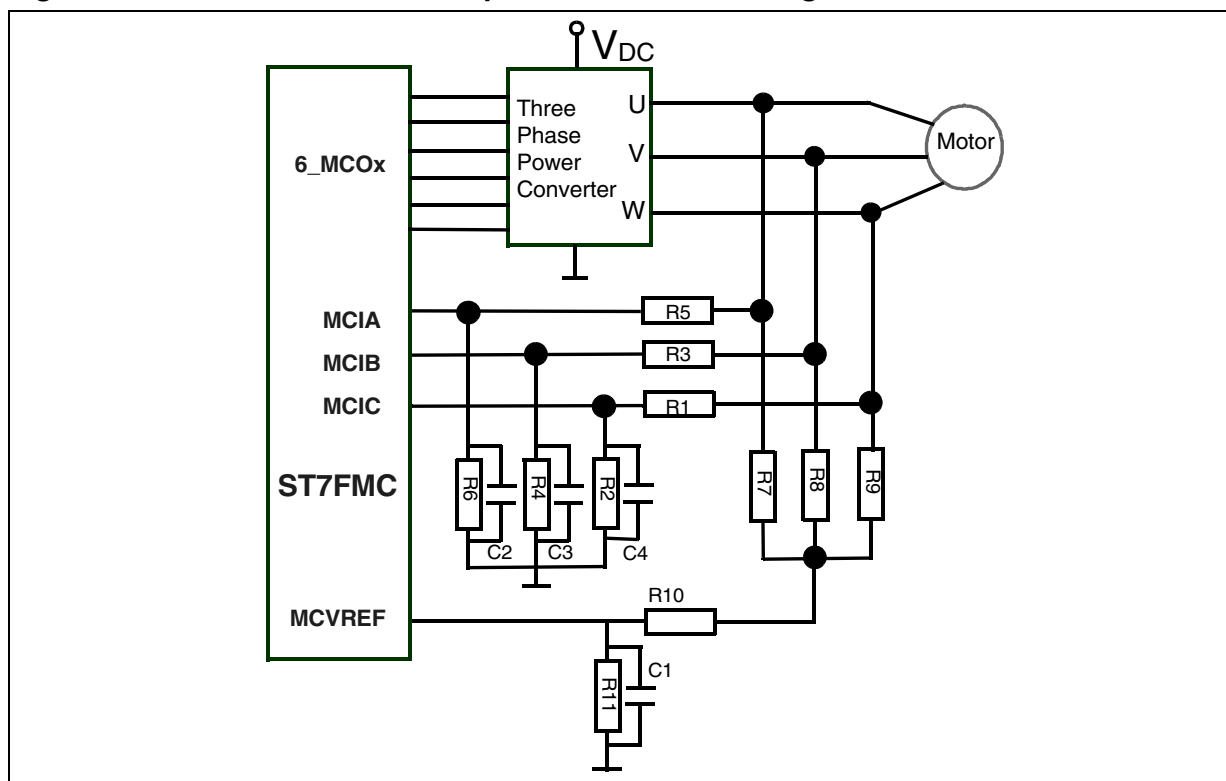

4.2.1 Components dimensioning

The sizing of network components is mainly dependant on the speed due to the variable level of BEMF. The following computations are done considering the zero value of the observed BEMF when we are near of the zero crossing time.

Dimensioning the RC Networks

During the PWM "ON" state we have the following motor phase polarization:

Phase A and B of the motor conduct current and phase C is the floating phase on which we can detect the BEMF.

An application running on mains (230Vac) is described, and control of the motor is done using the PWM principle running at a fixed frequency (18.1 KHz).

The Voltage Reference can be built using the virtual neutral of the motor using three resistors R7, R8 and R9, or using a voltage divider from the DC bus to be compatible with the input voltage of the comparator (5V). Another way is to use the internal voltage reference of ST7FMC and adapt the phase network divider to this voltage reference.

Figure 13. Two alternatives for virtual neutral rebuild

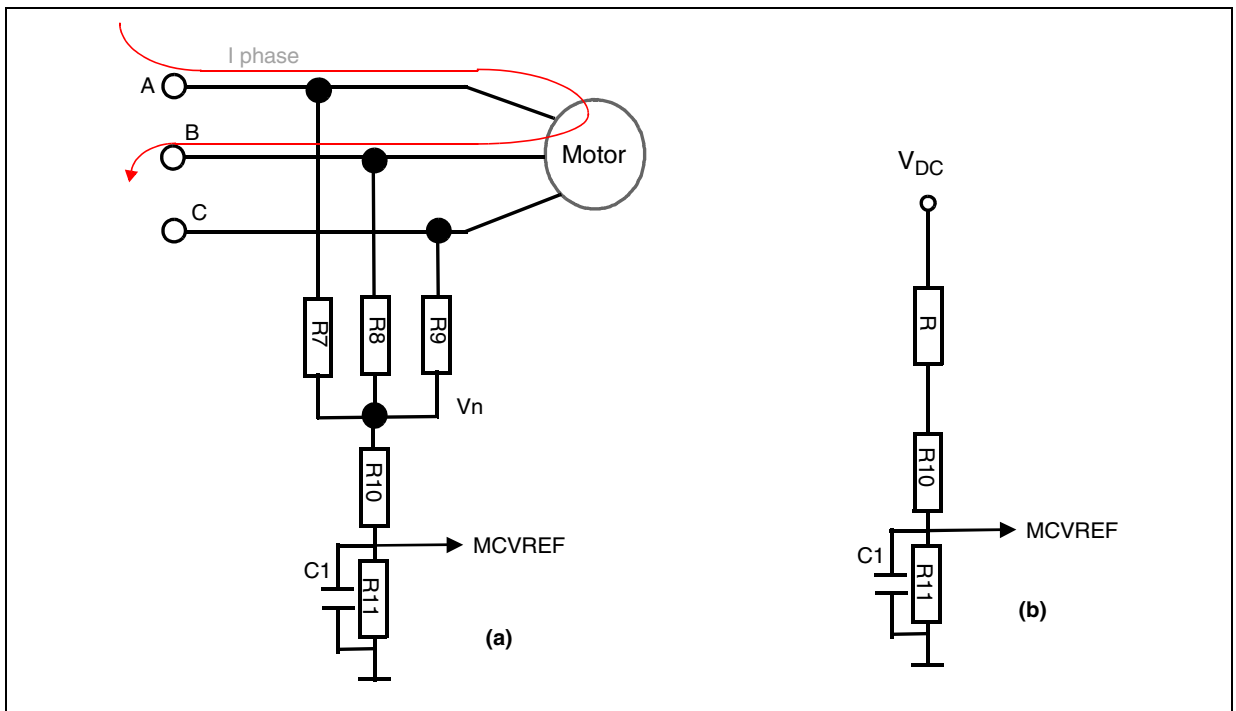

4.2.2 Size of Reference Voltage

a) The voltage level of virtual neutral V_n , for a mains application can be approximated to half of the maximum DC bus.

$$V_n = \frac{V_{DC}}{2} = \frac{325}{2} = 162.5V$$

We have to adapt the voltage level of virtual neutral to level acceptable by microcontroller. The target here is to fix the voltage reference with which BEMF is compared to Half of Microcontroller supply (5V).

The adaptation of the voltage is done with R10 & R11 resistors.

$$R10 = 270K \text{ and } R11 = 3.9K \text{ gives}$$

$$MCREF = 2.3V$$

The C1 capacitor allows filtering of the signal from the PWM drive of the motor.

At a PWM frequency of $f = 18.1 \text{ KHz}$ the corresponding period is $55\mu s$.

The equivalent resistor to R10 & R11 can be approximated to R11.

$$C1 = \frac{1}{(2 \times \pi \times f \times R11)} \quad \rightarrow \quad C1 = 2.2nF$$

With a coefficient of 10, this gives: $C1 = 22 \text{ nF}$

b) With a voltage divider on the DC bus, the voltage adaptation is done with R, R10 & R11 resistors.

The target here is to fix the reference voltage with which BEMF is compared to half of the Microcontroller supply (5V). So 2.5V corresponds to the value of the neutral point when PWM is ON.

$$R = 120K, R10 = 270K \text{ and } R11 = 2.7K \text{ which gives}$$

$$MCREF = 2.49V$$

c) For the use of an internal reference voltage this is set to 2.5V.

4.2.3 Size of BEMF sensing network

For each motor winding we have an identical network (R1 & R2 for Phase C) allowing the voltage to be adapted to the one acceptable by the microcontroller and again we need a capacitor (C4) to filter the signal.

Figure 14. Analog Sampling Implementation

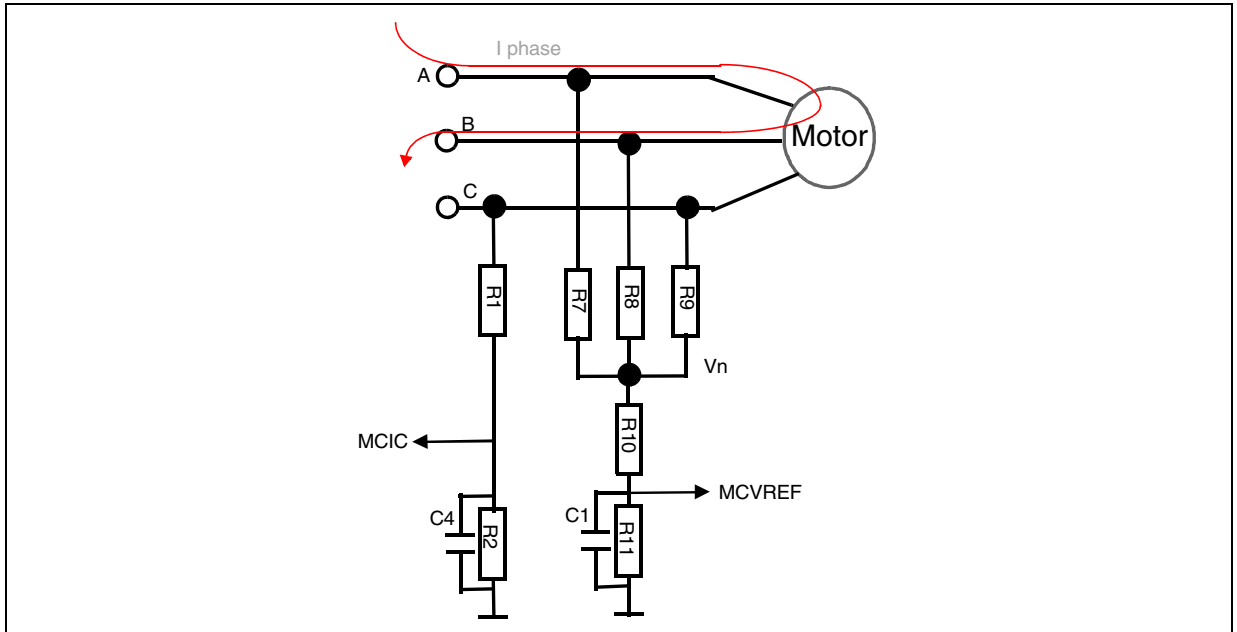

The sampling of BEMF is done during PWM ON, so the BEMF is centered on half of the DC bus:

$$V_n = \frac{V_{DC}}{2} = \frac{325}{2} = 162V$$

We have to adapt the voltage level of BEMF to the virtual neutral level already fixed to half of the Microcontroller supply (5V).

This voltage adaptation is done with the R1 & R2 resistors.

$$R1 = 180K \text{ and } R2 = 2.7K \text{ gives}$$

MCIC = 2.3V if we consider a zero value for E_c BEMF.

The C4 capacitor allows filtering of the signal due to the PWM drive of the motor.

At a PWM frequency of $f = 18.1$ KHz the corresponding period is $55\mu s$.

The equivalent resistor to R1 & R2 can be approximated to R2.

$$C4 = \frac{1}{(2 \times \pi \times f \times R2)} \quad \rightarrow \quad C4 = 3.2nF$$

With a coefficient of 10, the value is fixed for: $C4 = 27$ nF which is the lower normalized value.

For the classical sampling method ST7FMC allows sampling to be made at the PWM "ON" state after a programmable delay or PWM "ON" state at high frequency after a programmable delay.

Samplings at high frequency during PWM "ON" avoids getting jitter due to PWM frequency on the BEMF detection, and the Z event counter allows filtering during detection and rejection of spurious information.

4.3 PRACTICAL IMPLEMENTATION OF THE "CLASSICAL" METHOD, USING THE ST7MC-KIT/BLDC STARTER KIT

The ST7FMC starter kit board allows using a Daughter Board to run a BLDC motor using the classical BEMF detection circuit.

The Daughter Board is plugged onto the J11, W14, W15 & W16 connectors of the starter kit board as represented below.

Figure 15. Daughter Board place on Starter kit board

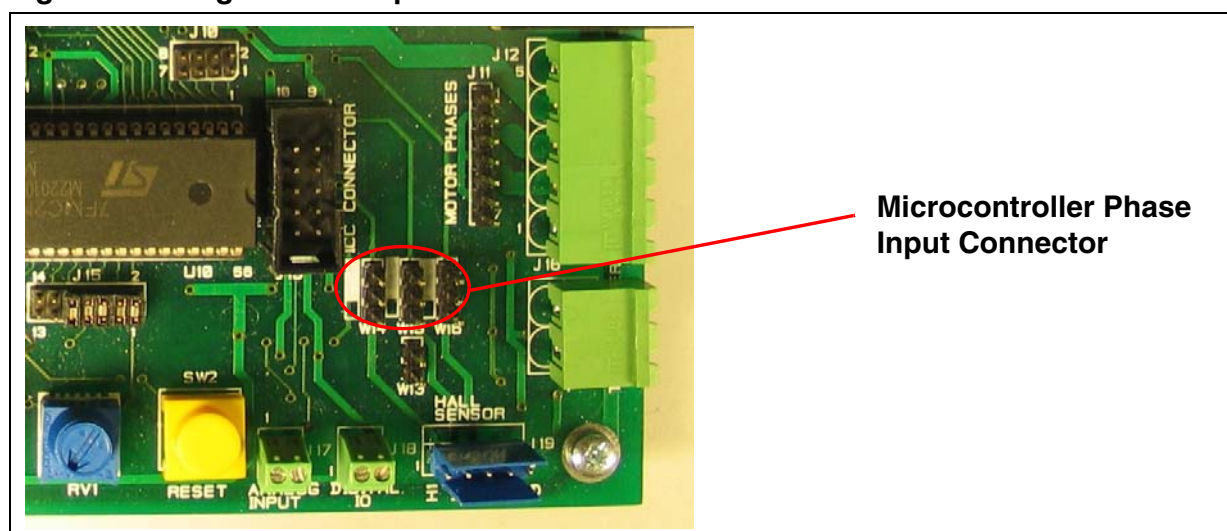

The photo in [Figure 16](#) shows a daughter board using a virtual neutral rebuild plug on the mother starter kit board.

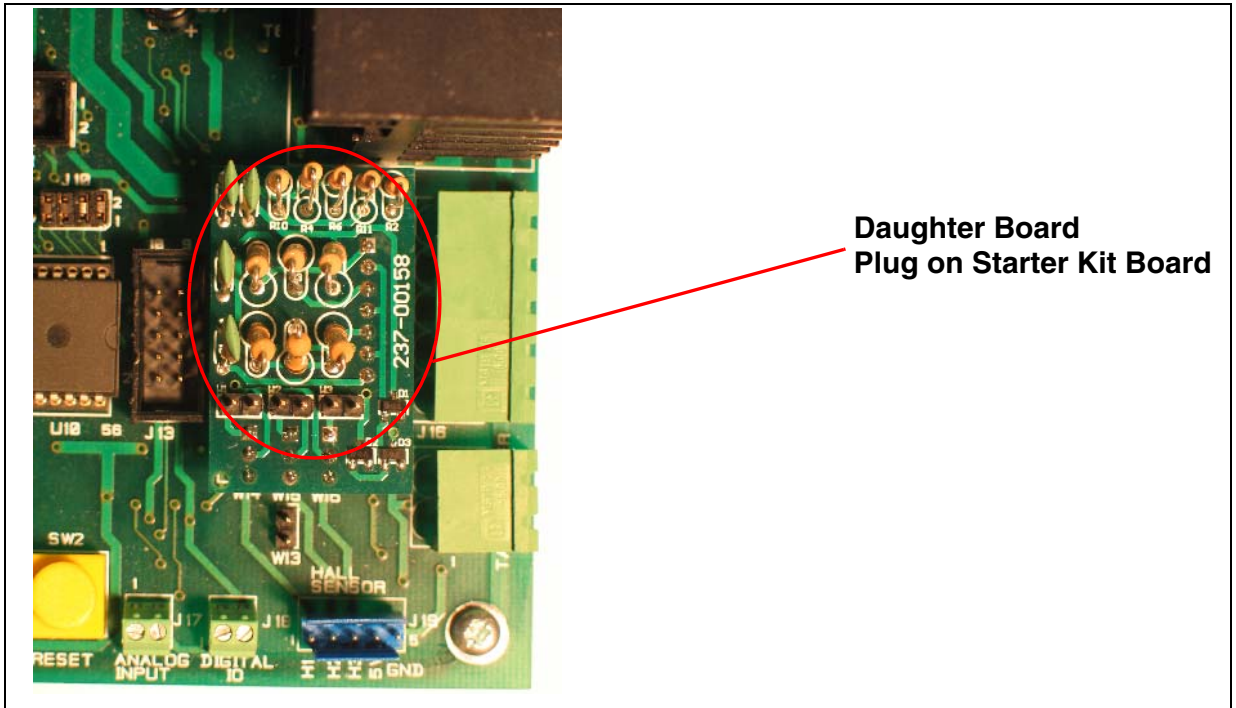
Figure 16. Daughter Board Plug on Starter Kit Board

4.4 PRACTICAL RESULTS

The following two figures show waveforms of both virtual neutral and Phase voltages at the input of the microcontroller for a motor running on mains.

The hardware end of the demagnetization detection is used and Z sampling is done during PWM “ON”.

[Figure 17](#) shows the observation of the demagnetization falling end event and the rising Zero crossing event for BEMF.

Figure 17. Falling Demagnetization for Rising Zero crossing detection

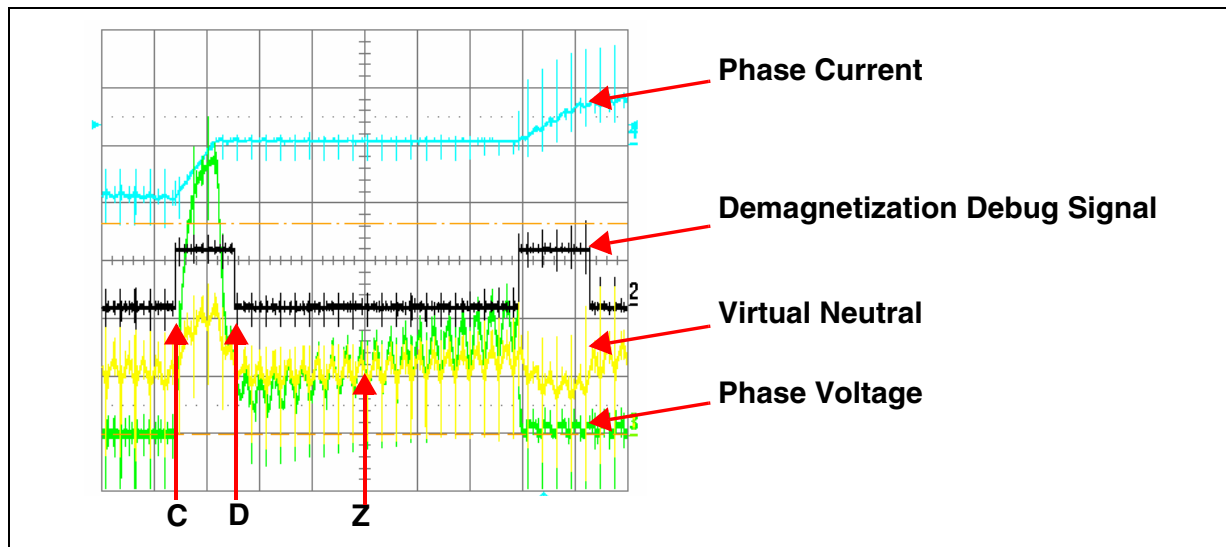
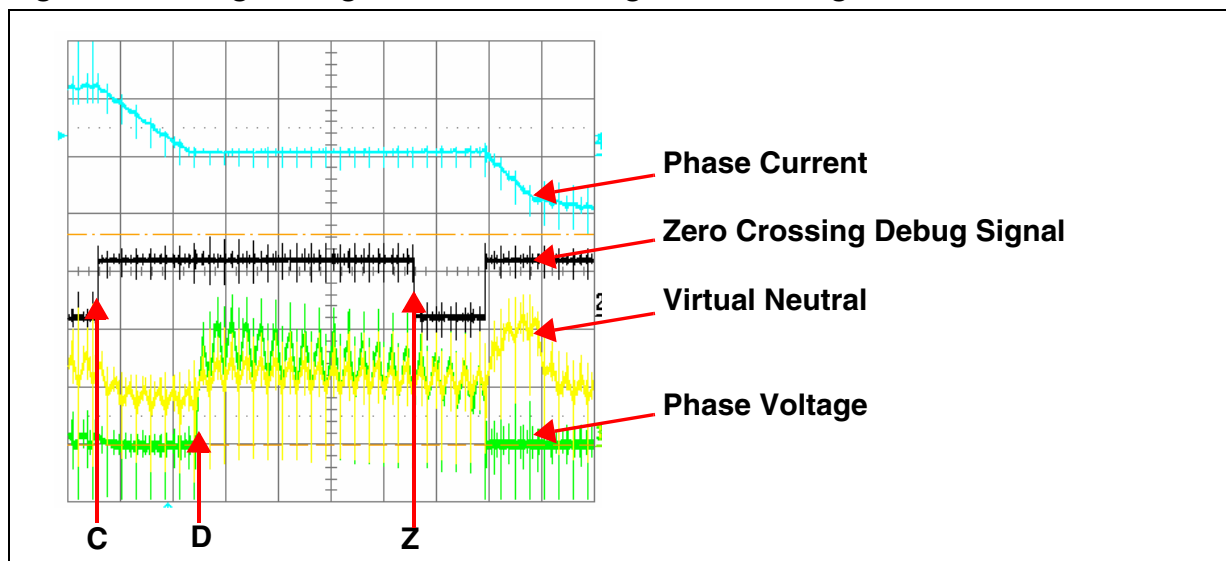

Figure 18 shows the observation of the demagnetization rising end event and falling Zero crossing event for BEMF.

Figure 18. Rising Demagnetization for falling Zero crossing detection



5 SAMPLING DURING PWM ON STATE USING DIGITAL FILTER

5.1 DESCRIPTION

The ST7MC microcontroller allows implementation of sampling with its full digital filter during PWM “ON” without an analog filter and is easier to network, to size and to implement.

Bits DS [3:0] of the MCONF register allow the configuration of the delay to be inserted before sampling after PWM ON

Sampling of BEMF can be done once at each PWM ON or at high frequency. For both sampling methods, an event counter (using the ZEF [3:0] bits in the MZFR register) allows filtering to avoid spurious detection.

In this method the BEMF of the observed phase is sampled during the PWM ON state.

Figure 19. Sampling during PWM “ON” state at high frequency

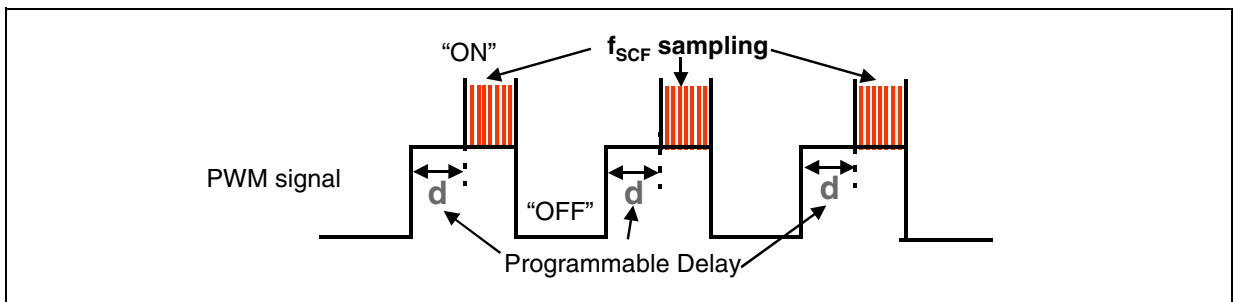

We have to implement a voltage divider to take care of the neutral voltage when the BEMF crosses the zero voltage. At this point, the zero voltage is centered on half of the DC bus.

Figure 20. Digital Sampling during PWM ON

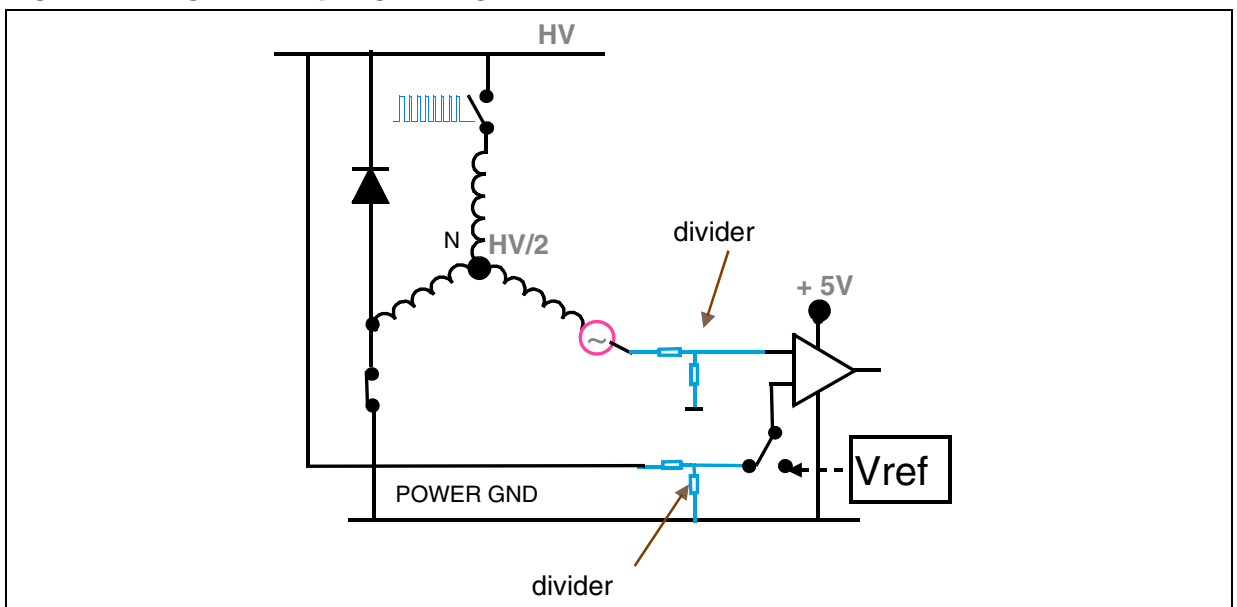

Advantages

This method of BEMF sampling is done during PWM “ON” state allowing up to a maximum duty cycle (100%). Use of high frequency sampling without analog filtering and with the possibility of digital filtering gives more flexibility to this method.

Drawbacks

This method is less sensitive than the ST method because the voltage divider is used to sense BEMF.

5.2 PRACTICAL IMPLEMENTATION

The following schema shows the network for sampling during PWM ON using a digital filter implemented with the use of an external reference voltage following the DC bus variation.

The network on the DC bus used to realize the reference voltage can be removed in the situation where the DC bus is constant.

In its place we use the internal programmable reference (from 0.2V to 3.5V) of the ST7MC.

Figure 21. Digital PWM ON Sampling Implementation

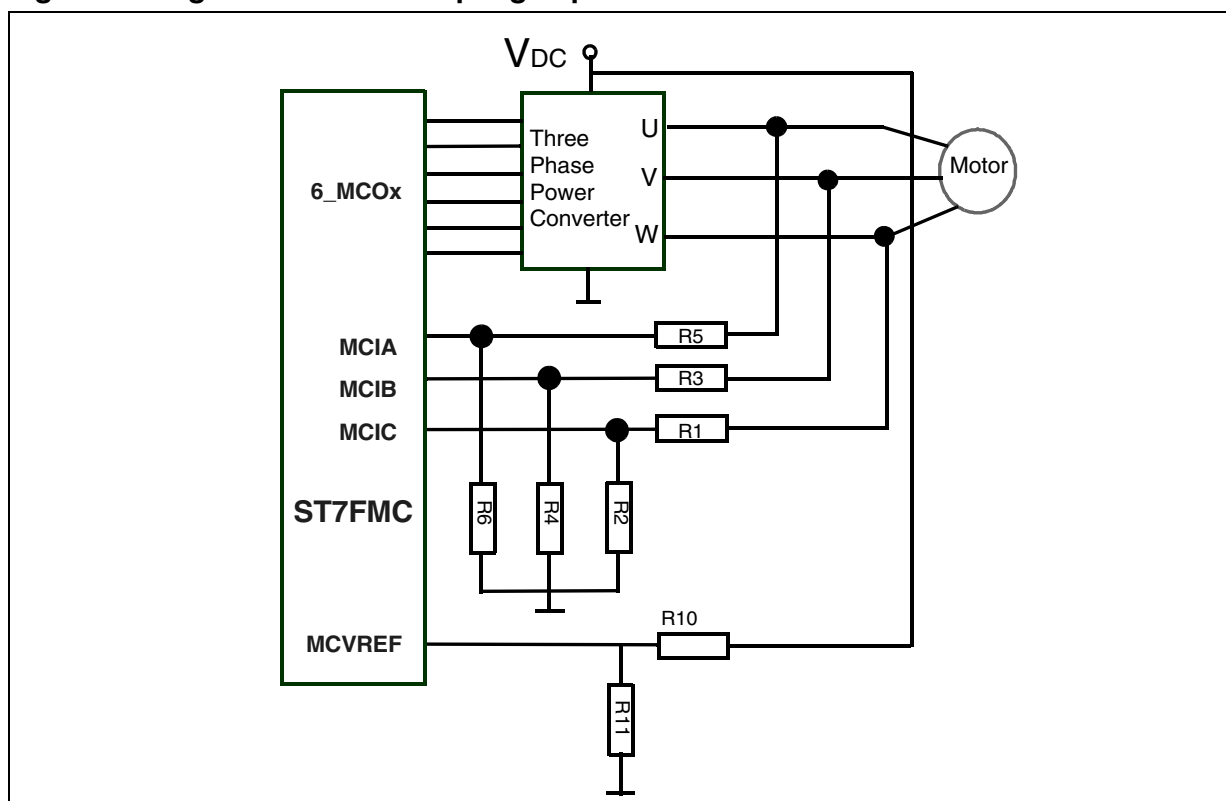

5.2.1 Sizing of network on motor phase

On each motor winding, if we consider a zero value of the BEMF voltage for the observed phase, we need a couple of resistors to pass the voltage from half of the DC bus to the level chosen for the reference voltage.

Sampling of BEMF is done during PWM ON, so the BEMF is centered on half of the DC bus:

$$V_n = \frac{V_{DC}}{2} = \frac{325}{2} = 162V$$

We have to adapt the voltage level of BEMF to the fixed reference voltage to be compatible with the Microcontroller supply (5V).

Figure 22. Network on Observed Phase

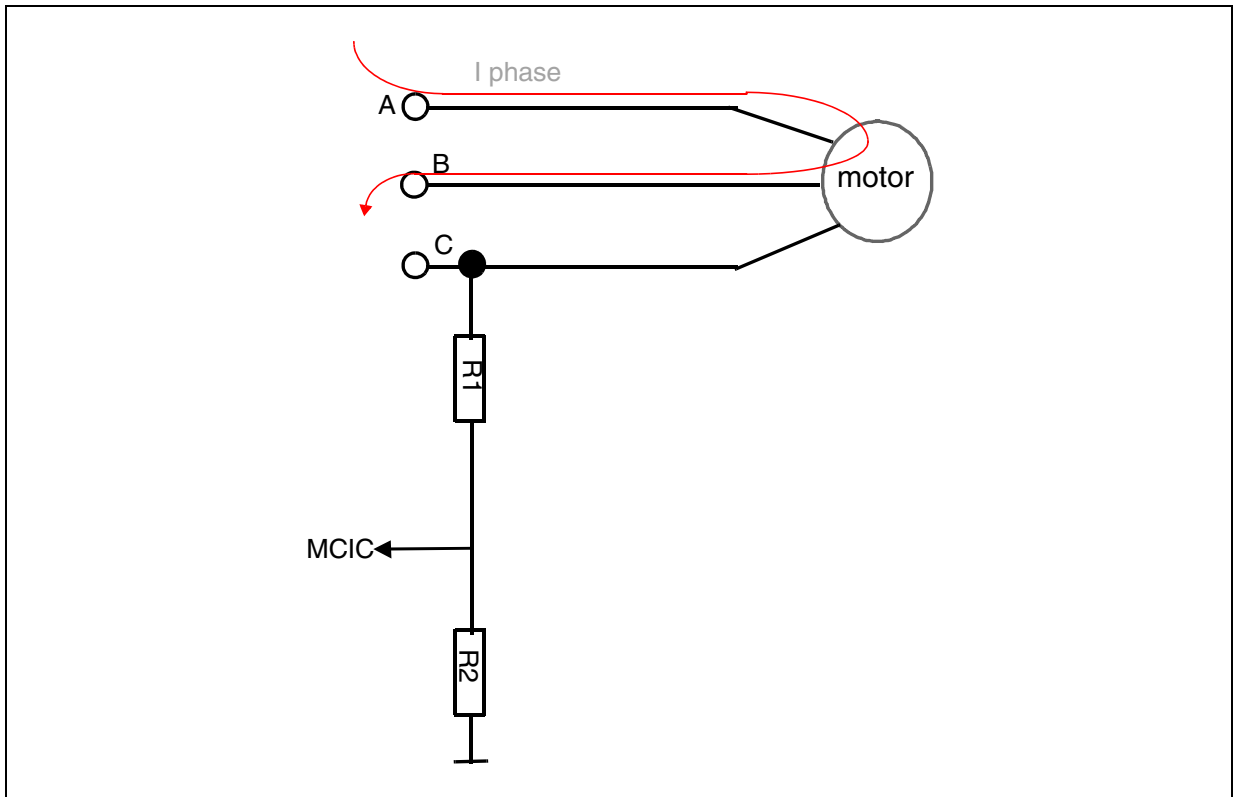

This voltage adaptation is done with R1 & R2 resistors.

R1 = 164K and R2 = 2.2K gives

MCIC = 2.1V if we consider a nil value for e_c BEMF.

5.2.2 Sizing of Network of Voltage Reference

The voltage comparator of ST7MC needs a voltage reference corresponding to the potential of motor phase winding common neutral point and equal to half of DC bus.

This voltage reference corresponds to the network sizing calculation on the motor phase (2.1V).

Figure 23. Network for Voltage Reference

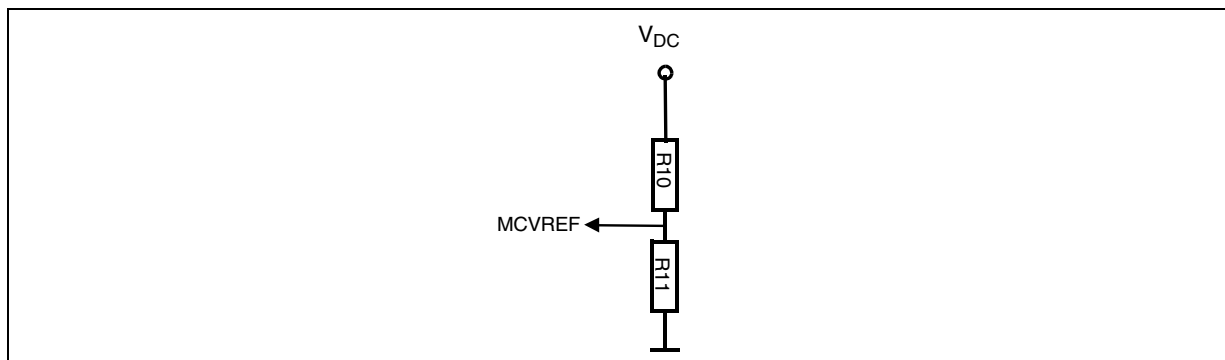

This voltage reference is built from the power converter DC bus to manage of any variation.

For the main application the DC bus is equal to 325V.

The voltage divider allows the voltage to pass from the DC bus (325V) to the determined voltage reference (2.1V).

This voltage adaptation is made with $R10$ & $R11$ resistors.

$R10 = 180K$ and $R11 = 1.2K$ giving

$MCVREF = 2.15V$

If we have a stable DC bus, the internal voltage reference of ST7MC can be used and in this case is set to 2V.

5.3 RECORDS OF DIGITAL SAMPLING DURING PWM ON

The figures below show sampling during PWM ON with a digital filter.

Figure 24. Rising BEMF sampling during PWM ON $V_{ref}=2V$

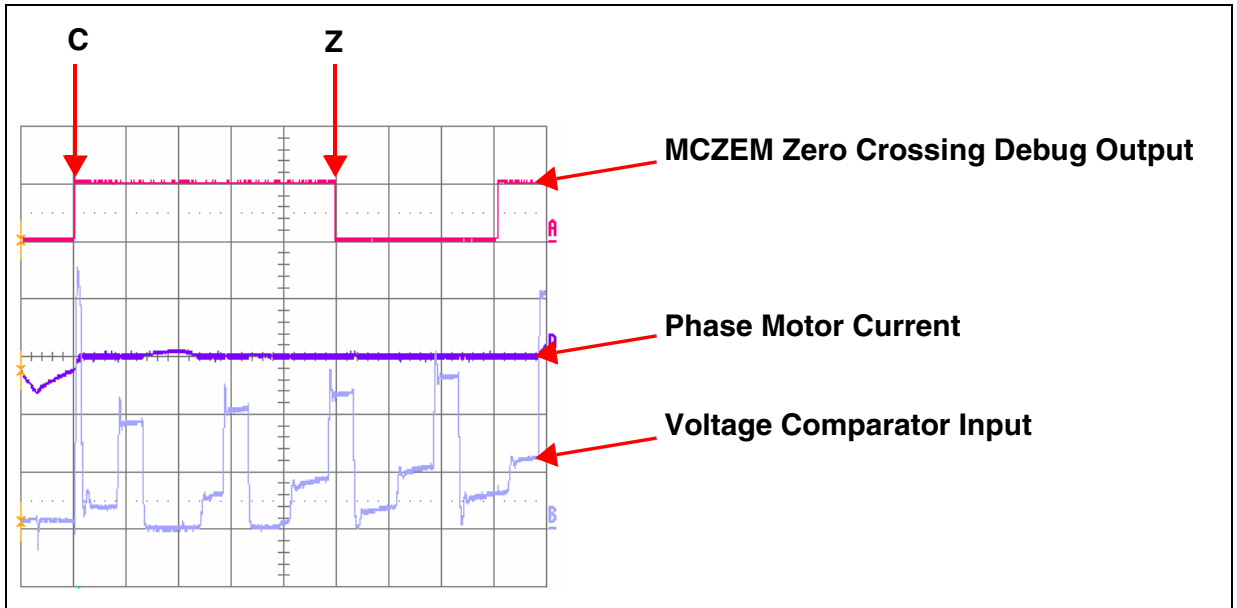
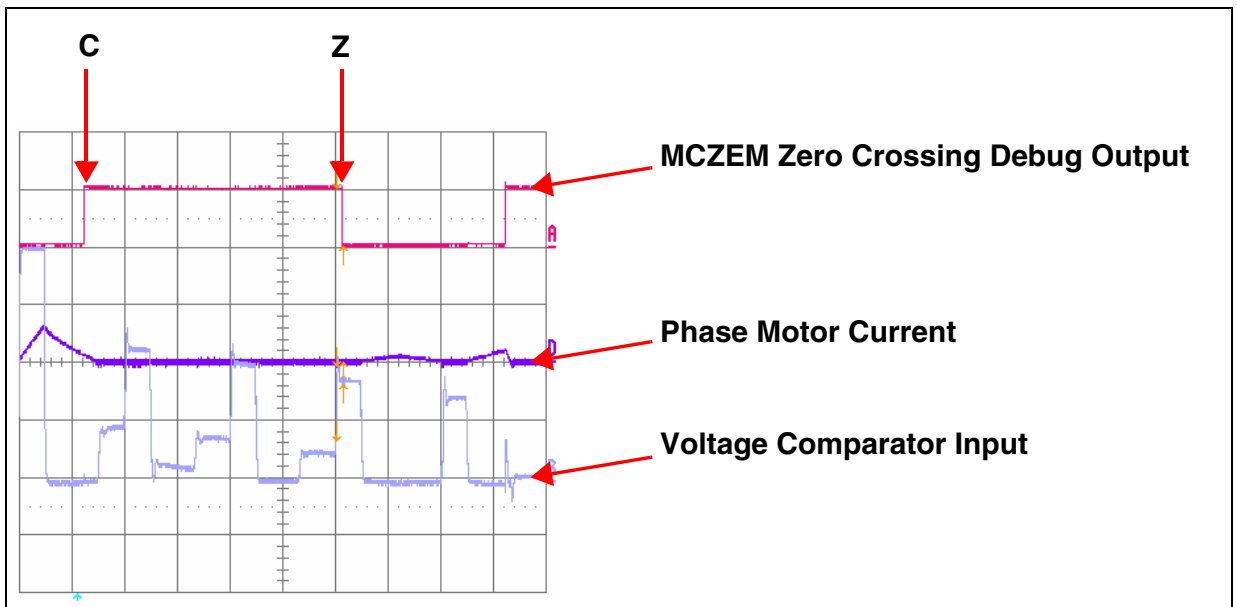

Figure 25. Falling BEMF sampling during PWM ON $V_{ref}=2V$



6 MIXED SAMPLING AT END OF PWM OFF AND DURING PWM ON

Sampling at the end of PWM OFF limits the duty cycle and hence does not allow 100% of the duty cycle on the motor.

Sampling during PWM ON needs a minimum ON state to be able to do sampling, so this can be a limitation in case of a low load of the motor.

For both sampling methods there is a limitation.

We can use the features of ST7MC passing from one sampling method to the other, covering all the PWM states.

The solution we present here proposes to start the motor using sampling at the end of PWM OFF allowing the motor to be run with a short PWM On and at low speed.

The BEMF sampling at PWM OFF needs only a serial resistor between the motor winding and the input voltage comparator of the microcontroller.

The sampling during PWM ON needs a voltage divider to get a voltage level compatible with the input of the voltage comparator.

The software driver of a classical I/O of a microcontroller used to drive the switch to enable a voltage divider on each input of the voltage comparator allows one configuration to pass to the other without perturbation of signal when sampling is done at end of PWM "OFF".

Figure 26. Mixed PWM state Sampling Implementation

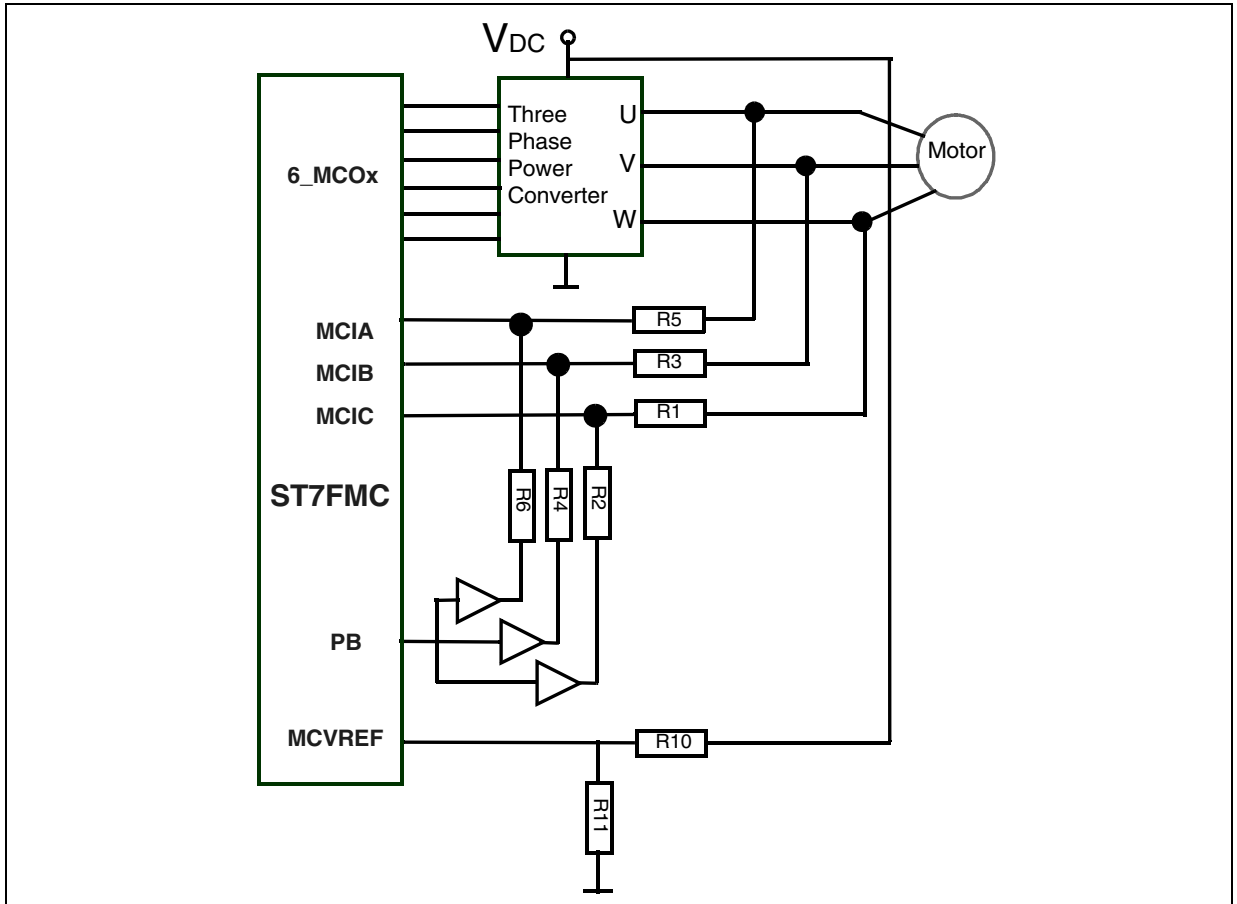

The application note AN2030 gives more detail on this mixed method allowing the motor to be run from low PWM ON state to 100% PWM duty cycle.

Advantages

With this mixed method of BEMF sampling, we keep the high sensitivity of the ST method based on sampling at the end of PWM "OFF" state for low speed where BEMF is low and we can run the motor at maximum speed using sampling during PWM "ON" state allowing up to a maximum PWM duty cycle (100%). Use of high frequency sampling without analog filtering and with possibility of digital filter gives more flexibility to this method.

Drawbacks

Due to the voltage divider used to sense BEMF during PWM "ON" state we have less sensitivity than for sampling at the end of PWM "OFF" state.

7 BEMF SAMPLING AT HIGH FREQUENCY METHOD (USED IN PULSE AMPLITUDE MODULATION METHOD)

The ST7FMC allows BEMF sampling at High Frequency whatever the PWM state. This sampling is useful in applications where the Pulse Amplitude Modulation (PAM) is used.

In this case, a PWM signal is used to monitor the level of the DC voltage bus using a DC/DC converter and motor commutations are done using a pure 6-step signal.

The sampling of BEMF is done permanently at high frequency on the non-energized phase.

This method allows the reduction in the switching noise of power converters due to the pure 6-step drive.

8 CHOICE OF SAMPLING METHOD

The Table below lists the main features of different possible sampling methods with ST7MC:

N°	Sampling Method	Strong point	Weak point	Comment
1	End of PWM "OFF"	High Sensitivity	No 100% PWM duty cycle	Preferable method where 100% duty cycle of PWM is not needed.
2	Classic PWM "ON"	Allow 100% PWM duty cycle	Analog Filter, Minimum on state	Motor speed dependent due to use of analog filter
3	PWM "ON" High Frequency	Allow 100% PWM duty cycle, use of digital filter	Minimum on state	If 100% duty cycle is needed and no request for low speed this method is preferable
4	Mixed PWM "ON" and PWM "OFF"	High Sensitivity at low speed and 100% PWM	Use additional I/O and management of speed transition	Best method if 100% duty cycle is needed and request of low speed drive
5	High frequency	Independent of PWM state	Need a specific management of DC bus	Dedicated to applications where switching noise of power converter is not acceptable.

Due to powerful digital features of ST7MC the classical method (n°2) can be eliminated. The high frequency sampling method (n°5) is dedicated to specific applications and cannot be considered for appliance applications like compressors, pumps, etc.

So this kind of sampling method application must be chosen between 1, 3 or 4.

The PWM duty cycle and the application speed range are the key parameters to select the well adapted sampling method.

9 CONCLUSION

In these days where inverter technology and permanent magnet motors are increasingly used in automotive, appliance and industrial applications, ST7MC offers a unique advantage; in conjunction with leading edge development tools, it allows any developer the chance to evaluate and choose the most suitable control method for his motor application.

Whatever the method chosen, ST7MC keeps system costs as low as possible, and maintains the highest standards of performance.

10 APPENDIX - IMPROVED BEMF DETECTION FOR LOW SPEED AND LOW VOLTAGE APPLICATIONS

10.1 THEORY

If phase A and B are conducting current, phase C is floating. The terminal voltage V_c is detected.

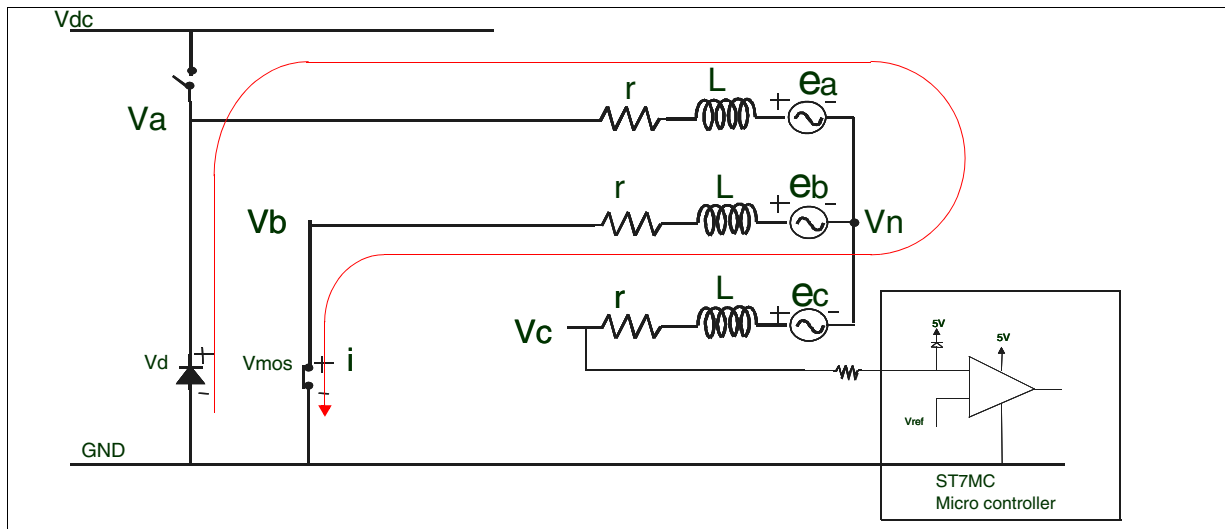

When the top transistor is turned off, the current freewheels through the diode D. During this freewheeling period, the terminal voltage V_c is detected as Phase C BEMF because there is no current in phase C.

In fact, $v_c = e_c + v_n$. Only when V_n equals zero, V_c is the Back EMF. As matter of fact, V_n is always non-zero.

From phase A, we have

$$v_n = 0 - v_d - ri - L \frac{di}{dt} - e_a \quad (1)$$

From phase B, we have

$$v_n = v_{mos} + ri + L \frac{di}{dt} - e_b \quad (2)$$

Where V_d is the forward voltage drop of the diode, V_{mos} is the voltage drop on MOSFET.

Adding (1) and (2), we get

$$2v_n = v_{mos} - v_d - (e_a + e_b) \quad (3), \text{ and}$$

$$v_n = \frac{v_{mos} - v_d}{2} - \frac{e_a + e_b}{2} \quad (4)$$

Also from the balance three-phase system, we have

$$e_a + e_b + e_c = 0 \quad (5)$$

From (3) and (4),

$$v_n = \frac{v_{mos} - v_d}{2} - \frac{e_c}{2} \quad (6)$$

So, the terminal voltage V_c ,

$$v_c = e_c + v_n = \frac{3}{2}e_c + \frac{v_{mos} - v_d}{2} \quad (7)$$

If we ignore the second term of (6), the terminal voltage is the Back EMF. However, at low speed and low voltage, the Back EMF itself is very small, the second term will play a significant role here. For low voltage MOSFET, R_d is very low, V_{mos} can be ignored, so (6) can be rewritten as,

$$v_c = e_c + v_n = \frac{3}{2}e_c - \frac{v_d}{2} \quad (8)$$

10.2 PROBLEMS

(a). As mentioned before, the voltage drop on the diode will affect the Back EMF significantly when the Back EMF is low. Theoretically, zero-crossing is evenly distributed each 60 electric degree. But because of the diode voltage drops, this will cause the zero-crossing to be unsymmetrically distributed.

Figure 27 shows the simulation result.

Figure 27. Simulation result shows the zero-crossing is unsymmetrical

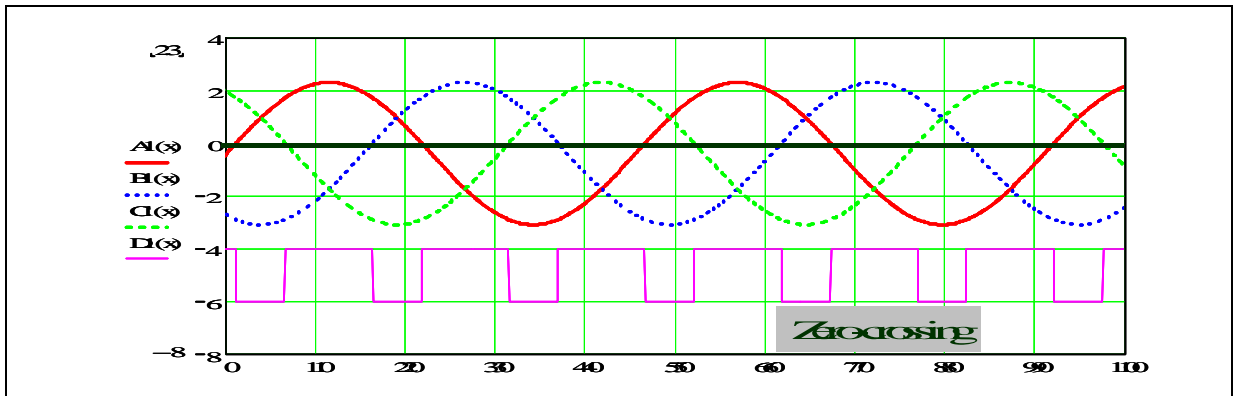
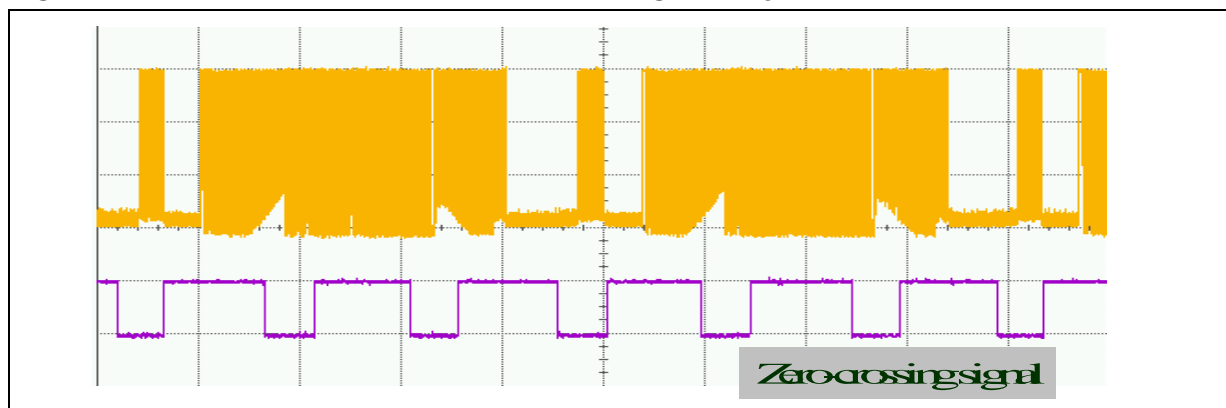

Figure 28 shows the testing result.

Figure 28. Test result shows the zero-crossing is unsymmetrical



The wrong zero detection will cause wrong commutation which probably will stall the motor. Also bad zero-crossing will cause bad speed regulation.

(b). At low voltage or low speed, the zero-crossing slope is very flat. The offset and the hysteresis loop of the comparator will cause the bad zero-crossing detection. Meanwhile, because of the low Back EMF, it is very susceptible to the noise.

10.2.1 Solution

To solve the first problem, we need to eliminate the effect of diode voltage drop. Adding another constant voltage before the voltage signal is sent to the comparator can eliminate the effect of the diode.

To solve the second problem, we need to sharpen the slope of the Back EMF during the zero crossing period. We can use an amplifier to amplify the Back EMF signal only around zero crossing time because we are not interested in other time periods.

Figure 29 shows the solution.

Figure 29. Solution to improve BACK EMF detection

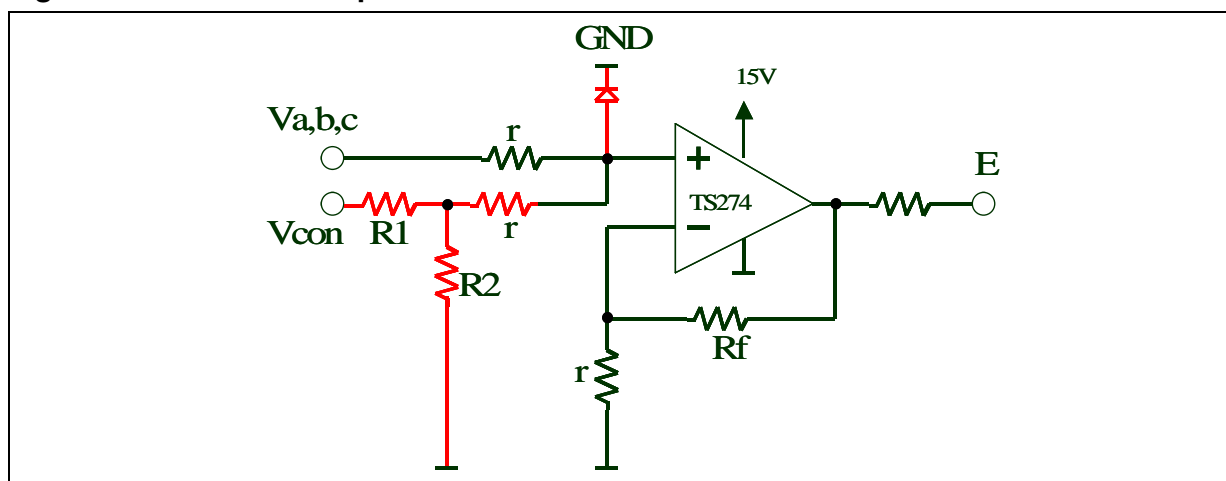

TS274 is a high speed Op-amp. Choose R1 and R2 such that $V_{con}R1/(R1+R2)=Vd/2$.

The positive input of the Op-amp is clamped at 0.7v by a diode because we are only interested in the zero crossing. So we only sharpen the slope of the back EMF near the zero crossing.

10.3 RESULT

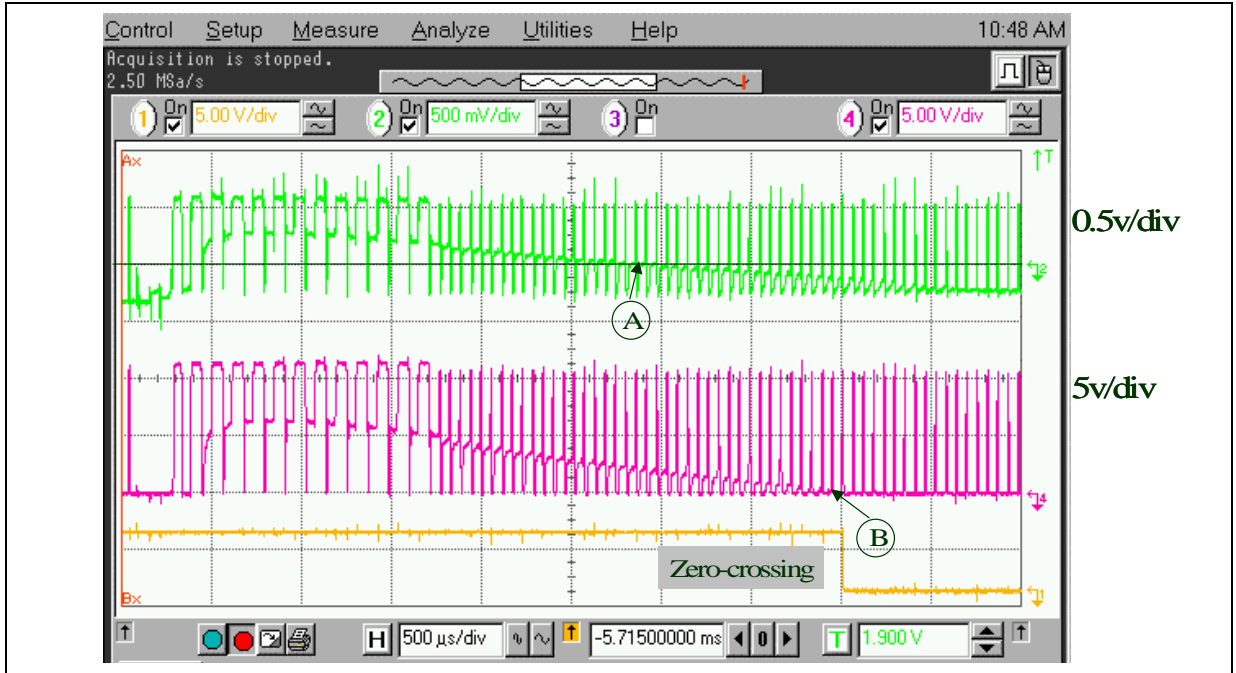

The green channel (top) is the signal directly from the winding, the terminal voltage, 0.5v/div. The back EMF signal is very weak. Point A will be the zero-crossing point.

The pink channel (middle) is the output from the Op-amp, 5v/div. Point B is the zero-crossing point.

Because of the diode forward voltage drop, at the real zero-crossing point, the terminal voltage is negative.

The amplification makes the slope very sharp.

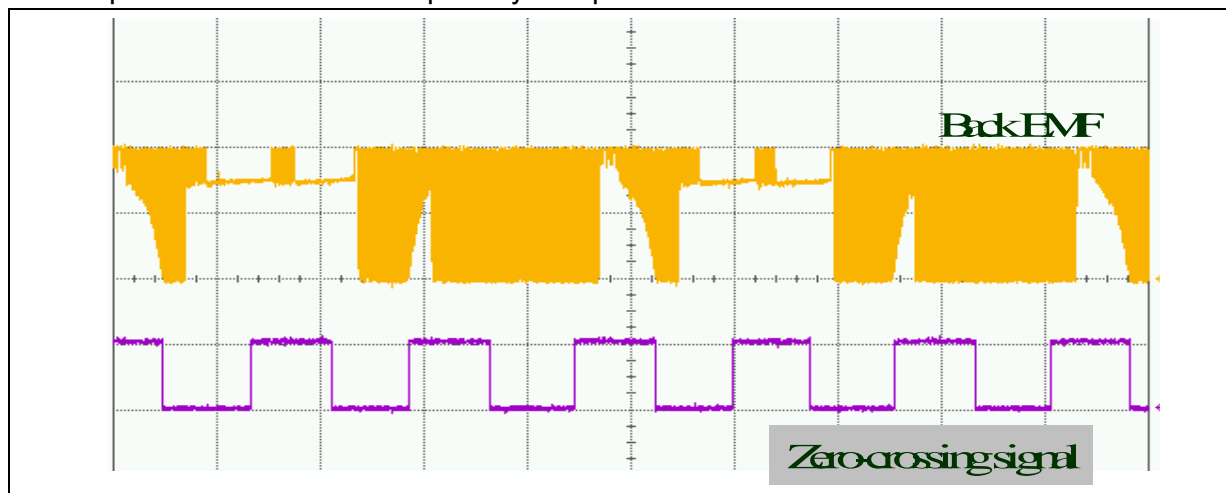

Now, the zero crossing signal is in very good shape.

10.4 CONCLUSION

The theory clearly explains the mechanism of the Back EMF detection and shows the drawback of the original detection method.

The preconditioning circuit not only eliminates the effect of the diode forward voltage drop, but also sharpens the slope of the Back EMF during the zero crossing period.

This circuit can greatly improve the performance of sensorless BLDC drive in low voltage applications, especially automotive. With this technique, the sensorless driver can be used with a much wider speed range. For example, using the original detection method, the speed range can only be 30-150 rpm. Using the improved method, the speed range can be 3-150rpm.

11 REVISION HISTORY

Table 1. Document revision history

Date	Revision	Changes
10-Jan-2005	1	Initial release
12-Jul-2007	2	Removed references to obsolete products

Please Read Carefully:

Information in this document is provided solely in connection with ST products. STMicroelectronics NV and its subsidiaries ("ST") reserve the right to make changes, corrections, modifications or improvements, to this document, and the products and services described herein at any time, without notice.

All ST products are sold pursuant to ST's terms and conditions of sale.

Purchasers are solely responsible for the choice, selection and use of the ST products and services described herein, and ST assumes no liability whatsoever relating to the choice, selection or use of the ST products and services described herein.

No license, express or implied, by estoppel or otherwise, to any intellectual property rights is granted under this document. If any part of this document refers to any third party products or services it shall not be deemed a license grant by ST for the use of such third party products or services, or any intellectual property contained therein or considered as a warranty covering the use in any manner whatsoever of such third party products or services or any intellectual property contained therein.

UNLESS OTHERWISE SET FORTH IN ST'S TERMS AND CONDITIONS OF SALE ST DISCLAIMS ANY EXPRESS OR IMPLIED WARRANTY WITH RESPECT TO THE USE AND/OR SALE OF ST PRODUCTS INCLUDING WITHOUT LIMITATION IMPLIED WARRANTIES OF MERCHANTABILITY, FITNESS FOR A PARTICULAR PURPOSE (AND THEIR EQUIVALENTS UNDER THE LAWS OF ANY JURISDICTION), OR INFRINGEMENT OF ANY PATENT, COPYRIGHT OR OTHER INTELLECTUAL PROPERTY RIGHT.

UNLESS EXPRESSLY APPROVED IN WRITING BY AN AUTHORIZED ST REPRESENTATIVE, ST PRODUCTS ARE NOT RECOMMENDED, AUTHORIZED OR WARRANTED FOR USE IN MILITARY, AIR CRAFT, SPACE, LIFE SAVING, OR LIFE SUSTAINING APPLICATIONS, NOR IN PRODUCTS OR SYSTEMS WHERE FAILURE OR MALFUNCTION MAY RESULT IN PERSONAL INJURY, DEATH, OR SEVERE PROPERTY OR ENVIRONMENTAL DAMAGE. ST PRODUCTS WHICH ARE NOT SPECIFIED AS "AUTOMOTIVE GRADE" MAY ONLY BE USED IN AUTOMOTIVE APPLICATIONS AT USER'S OWN RISK.

Resale of ST products with provisions different from the statements and/or technical features set forth in this document shall immediately void any warranty granted by ST for the ST product or service described herein and shall not create or extend in any manner whatsoever, any liability of ST.

ST and the ST logo are trademarks or registered trademarks of ST in various countries.

Information in this document supersedes and replaces all information previously supplied.

The ST logo is a registered trademark of STMicroelectronics. All other names are the property of their respective owners.

© 2007 STMicroelectronics - All rights reserved

STMicroelectronics group of companies

Australia - Belgium - Brazil - Canada - China - Czech Republic - Finland - France - Germany - Hong Kong - India - Israel - Italy - Japan - Malaysia - Malta - Morocco - Singapore - Spain - Sweden - Switzerland - United Kingdom - United States of America

www.st.com