



SOFT LIGHT DIMMER

by J. M. Charreton

1. INTRODUCTION

The circuit described in this paper is a new proposal for dimming incandescent lamps which offer a resistive load, and halogen lamps with their electronic converter which are, in effect, capacitive loads.

Power, in conventional dimming circuits, is controlled by TRIACs. They require a series inductor for RFI filtering and a fuse to protect them against overload and short circuit conditions. Additionally, the fuse may require maintenance. The circuit is potentially noisy due to the AC current flowing through the inductor.

In this new circuit design, power is controlled by means of an IGBT. The IGBT switching behaviour can be slowed down at turn-on and turn-off, hence a series inductance need not be used. An additional feature is that the circuit can be designed to provide short circuit protection which eliminates the need for a fuse and the necessary access for fuse replacement. There is virtually no acoustic noise.

2. MAIN FEATURES

The power supplied to the load can be adjusted between 0 and 90%. Control is achieved by varying the conduction time of the IGBT. Because the IGBT is controlled at turn-off, overload and short circuit protection can be implemented - a feature that removes the need to incorporate a fuse.

Slowing down the rate at which the current falls at turn-off reduces the amount of R.F.I. generated and avoids the use of a series choke. It also reduces any tendency for audible noise generation.

IGBTs, unlike TRIACs, do not have a threshold current limit. This means that no flicker is observed as is the case when using TRIACs.

This dimmer can work at any mains voltage by adapting the power switch to the load.

In order to use the full half sine wave of the rectified mains voltage, the time constant can be adjusted from, for example, 0ms to 9 ms (approximately half of the full wave period) in the case of a 50Hz mains system.

The circuit complies with the IEC5555¹ norm when controlling a load up to a limit of 1kW.

3. PROPOSED SOLUTION

3.1 Circuit description

The light dimmer uses an isolated gate power

switch such as a MOSFET or an IGBT. A controlled AC switch is made by using the power switch to control a diode bridge, figure 1.

Figure 1: Block schema

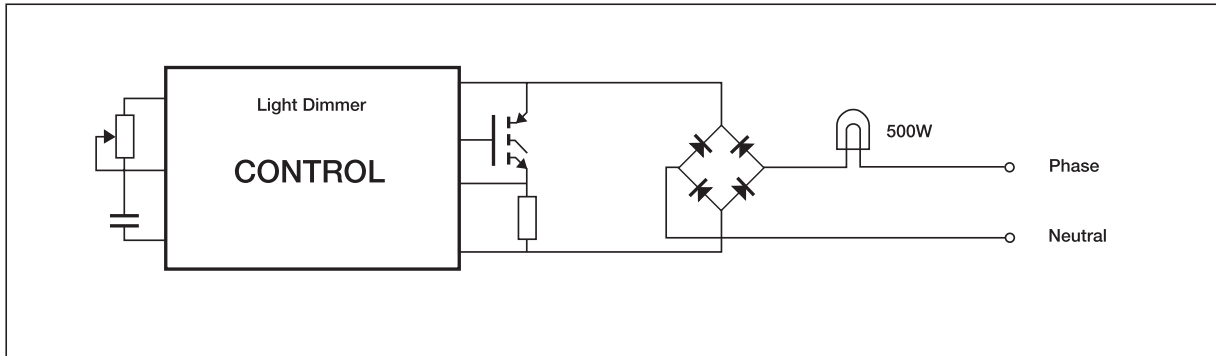

A standard timer, a TS555 controls conduction in the power switch. This controls the light intensity. The timer is triggered on the zero voltage crossing of the rectified mains voltage.

Short circuit protection.

Should a short circuit occur, the over-current is sensed across the shunt resistor. As soon as the shunt voltage reaches a predetermined level, the power switch is turned off and the timer is reset for a long enough period to avoid spurious restart.

Short circuit protection eliminates the need for a fuse which would otherwise be a heat source in the circuit.

Control of di/dt and dV/dt .

di/dt can be slowed down both at turn-on and turn-off by placing a small inductor in the emitter lead of the IGBT. The current variations are controlled by the IGBT itself. During di/dt the voltage across the inductor ($e=L di/dt$) must be equal to the gate-source voltage minus the Miller effect voltage, figure 2.

Figure 2: di/dt control

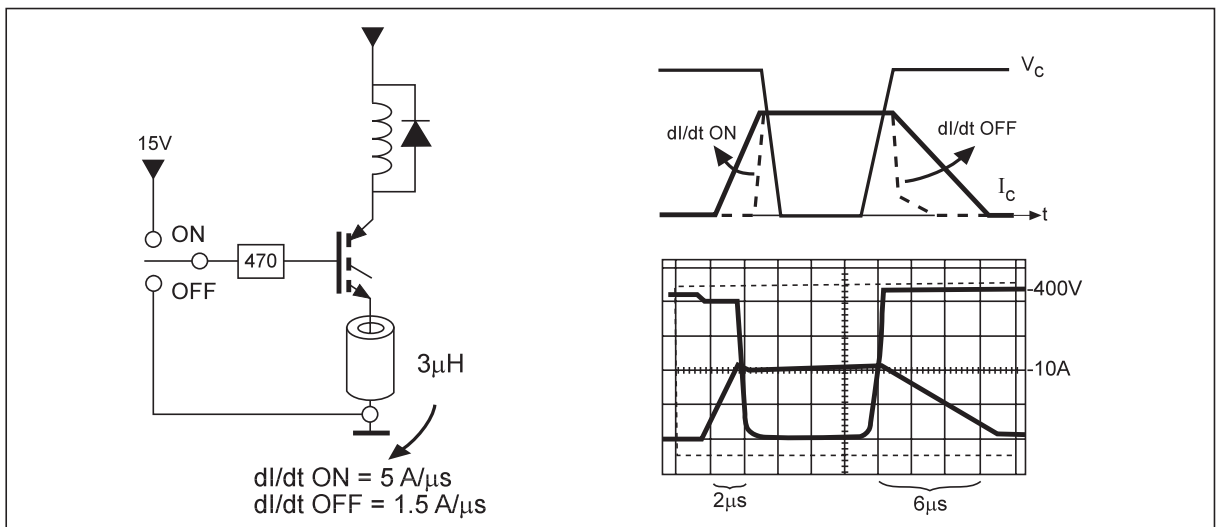

dV/dt can be drastically slowed down at turn-off by using a very high value of gate resistor (R_{goff}) to turn off the IGBT. The typical dV/dt can be reduced by a factor of 1000 compared to normal switching. Reducing dV/dt results in the losses being

low when switching at a frequency of 100Hz. During dV/dt the IGBT is desaturated. The current through the Miller capacitor ($i=C dV/dt$) flows through the gate resistor generating a voltage equal to the gate threshold voltage, figure 3.

Figure 3: dV/dt control

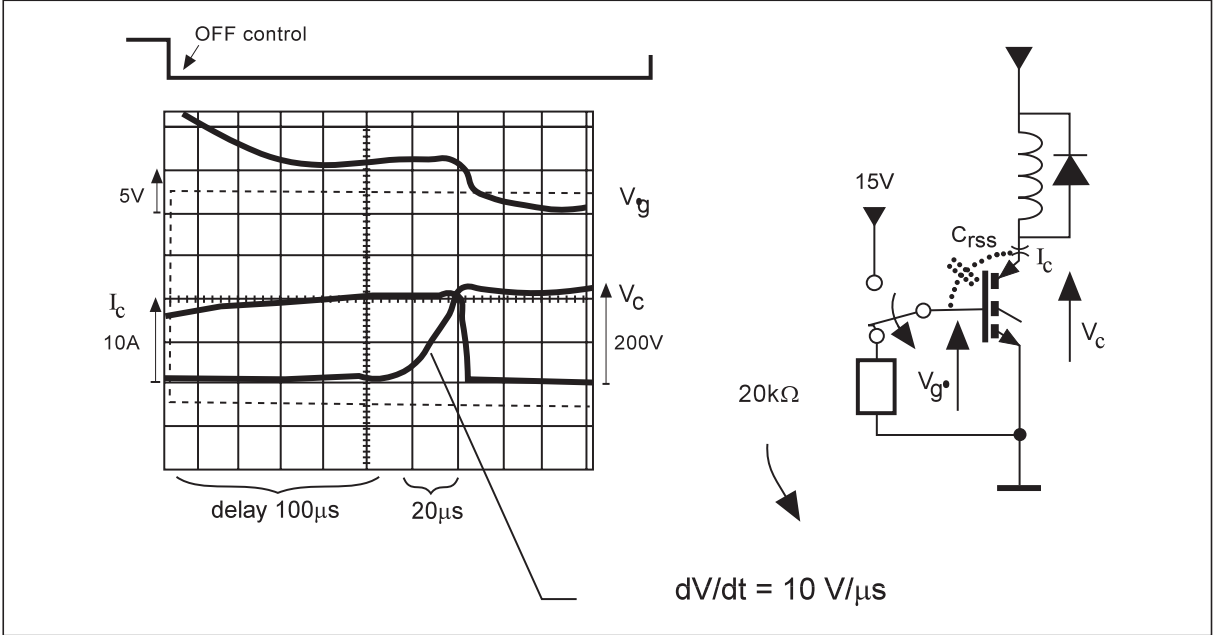

The advantages of controlling dV/dt and dI/dt are that EMI is reduced and hence the cost of filters is reduced. Eliminating the series inductor also saves valuable space on the printed circuit board and eliminates the magnetic constriction noise.

3.2 Power Switch: Selection and Performance

Basically, both power MOSFETs and IGBTs are both well suited for use in this application. Evaluations of the performance of this light dimmer have been made using both types of power switch. The results are given in Table 1.

Evaluation of the losses showed:

- turning on at zero crossing voltage eliminates turn-on losses

- the conduction losses are dependent on the type of power switch and the conduction time,
- by slowing down the turn-off switching, the losses at this point in the switching cycle are the same for both types of power switch and are at a maximum at 50% conduction time.

Conditions:

- for this evaluation, power switches with the same die size were used.
- the Power MOSFET STP5N50 has an $R_{DS(on)} = 1.5\Omega$ at $25^\circ C$ and the IGBT STGP10N50A has $V_{CE(on)} = 1.8V$ at $I_c = 10A$ and $T_c = 100^\circ C$.

The results in Table 1 are for a load of 300W.



APPLICATION NOTE

TABLE 1: Power switch comparison, MOSFET vs. IGBT, using a 300W load.

CONDUCTION MODE	MOSFET		IGBT	
	Conduction losses	Switching losses	Conduction losses	Switching losses
HALF-WAVE	3.2W	1.2W	1.2W	1.2W
FULL-WAVE	4W		1.8W	

As the losses in the IGBT were lower than those in the power MOSFET, the IGBT was chosen as the power switch for this application.

Further evaluation of the IGBT as a power switch, using an increased load of 500W, gave the results shown in Table 2. The data was obtained using a heat sink rated at 17°C/W and at an ambient temperature of 23°C.

TABLE 2: Working temperature of sources of heat in the light dimming circuit.

	Half-wave conduction $t_{on} = 5ms$	Full-wave conduction $t_{on} = 8.5ms$
Power switch heatsink	61°C	61°C
Sense resistor	58°C	70°C
Rectifier diode	60°C	80°C

TABLE 3: Heat losses in the power switch, sense resistor and rectifier diode.

Source of power losses	Half-wave conduction $t_{on} = 5ms$	Full-wave conduction $t_{on} = 8.5ms$
Power switch	2.7W	3.1W
Sense resistor	0.3W	0.5W
Rectifier diode	2.3W	4.1W

Figure 4: SOFT LIGHT DIMMER

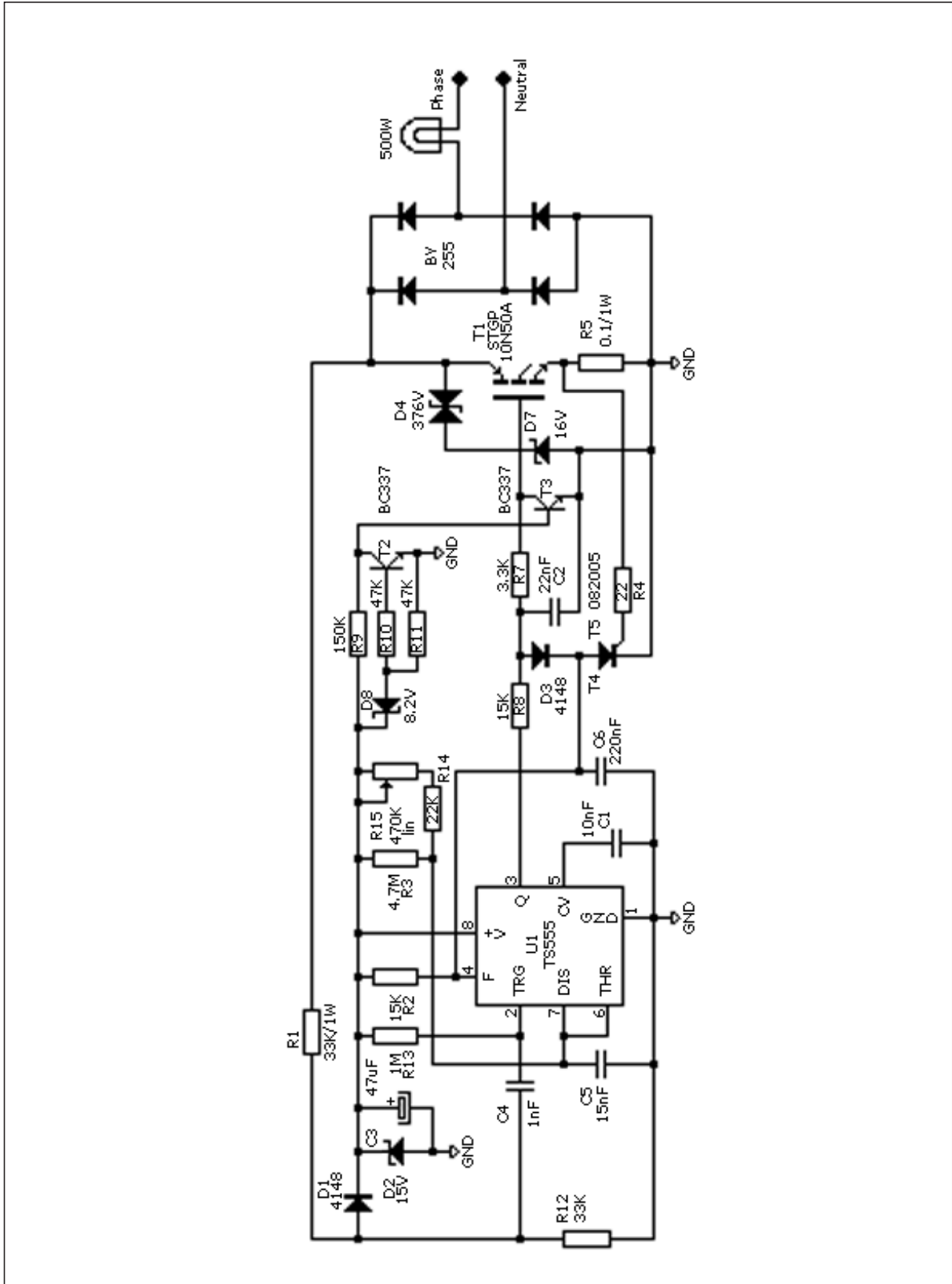

4. PRACTICAL REALIZATION

The heart of the circuit is the TS555 timer and the IGBT STGP10N50A. The complete schematic is shown in figure 4.

The timer is triggered on the zero crossing voltage pulse. The conduction angle is dependent on the time constant determined by $C5/R14+R15$.

In order to guarantee that a correct voltage level is applied to the gate of the IGBT, the under-voltage control, T2 - T3, inhibits the power switch until the auxiliary supply voltage reaches 8V.

Over-current and short circuit protection

are based on the current sense resistor, R5. When the voltage across R5 reaches the gate trigger voltage of the sensitive gate thyristor, T4, the gate of the IGBT is taken low and it turns off. At the same time the timer is reset. This current limiting also provides automatic soft-start and hence protection against excessive in-rush current.

Figure 5 shows the equivalent circuit of a load which includes an equivalent line inductance. When an overload or short circuit occurs, the power switch is turned off. At this time the energy stored in the inductance is dissipated in the IGBT through the transil diode D4, making the IGBT operate as a power zener clamping

Figure 5: Equivalent Schema with Line Inductance

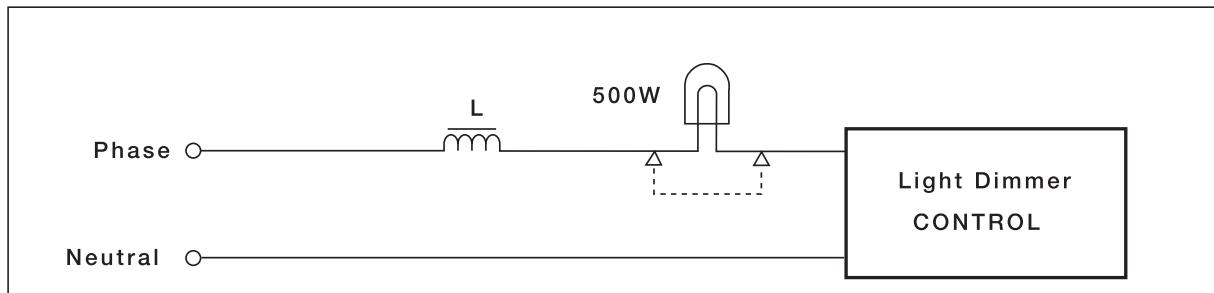

diode. The IGBT must be sized to sustain the energy stored in the inductance during this period (see figure 6).

If the short circuit is still present at the next mains crossing, the IGBT is turned on until the current protection is reached. This means that, in permanent short circuit

conditions, a series of current pulses are produced. Therefore the IGBT should be sized to sustain the resulting energy.

Figure 6 illustrates the collector voltage and current when an accidental short circuit occurs and is followed by a permanent short circuit.

Figure 6: Short Circuit Behaviour

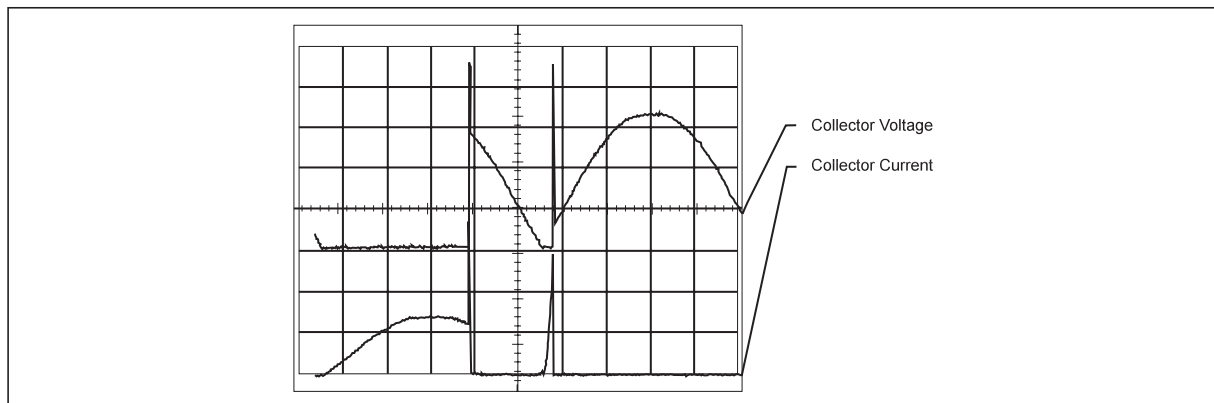

At the time of the short circuit, the power switch must sustain the energy stored in the line inductance. Switching off the current generates an over-voltage. The IGBT is protected from the over-voltage by a transil placed between the drain and the gate.

A summary of the switching losses for normal operation, accidental short circuit and for a permanent short circuit are given in Table IV.

The TS555 timer is reset for a period of about 5ms to prevent parasitic turn-on of the power switch due to the voltage oscillations that can occur after current limiting.

The auxiliary power supply is provided during the off state of the power switch. This means there is a conduction time

Table 4: Stress on the switch for a load containing a series inductor.

Parasitic Line Inductance	Maximum switching losses 500W(100Hz)	Energy for short circuit during conduction	Losses (100Hz)for Turn-on Short Circuit
80 μ H	0.9W	9mJ	6mW
1.5mH	1.6W	0.2J	2.9W

ranging from 0% to 90%. Hence the power supplied to the load varies between 0% and 90%.

5. CONCLUSION

di/dt control of an IGBT in a light dimming application reduces the amount of R.F.I. generated and avoids the use of a series inductor for this purpose as is used in the case of a more conventional dimmer.

Removing the inductor makes the circuit noiseless and saves printed circuit board space.

If over-current protection is provided, no conventional fuse is necessary while the self protection of the circuit is enhanced with short circuit protection and control over the in-rush current.

¹Norm concerning disturbances in supply systems caused by household appliances and similar electrical equipment.

Information furnished is believed to be accurate and reliable. However, STMicroelectronics assumes no responsibility for the consequences of use of such information nor for any infringement of patents or other rights of third parties which may result from its use. No license is granted by implication or otherwise under any patent or patent rights of STMicroelectronics. Specification mentioned in this publication are subject to change without notice. This publication supersedes and replaces all information previously supplied. STMicroelectronics products are not authorized for use as critical components in life support devices or systems without express written approval of STMicroelectronics.

The ST logo is a trademark of STMicroelectronics

© 1999 STMicroelectronics - Printed in Italy - All Rights Reserved

STMicroelectronics GROUP OF COMPANIES

Australia - Brazil - China - Finland - France - Germany - Hong Kong - India - Italy - Japan - Malaysia - Malta - Morocco -
Singapore - Spain - Sweden - Switzerland - United Kingdom - U.S.A.

<http://www.st.com>