

Tachometers

A permanent magnet DC motor may be used as a tachometer. When driven mechanically, this motor generates an output voltage that is proportional to shaft speed (see Fig. 4.1). The other main requirements for a tachometer are that the output voltage should be smooth over the operating range and that the output should be stabilized against temperature variations.

Small permanent magnet DC “motors” are frequently used in servo systems as speed sensing devices. These systems usually incorporate thermistor temperature compensation and make use of a silver commutator and silver loaded brushes to improve commutation reliability at low speeds and at the low currents, which are typical of this application.

To combine high performance and low cost, DC-servo motor designs often incorporate a tachometer mounted on the motor shaft and enclosed within the motor housing (Fig. 4.1).

Fig. 4.1 Tachometer output characteristics

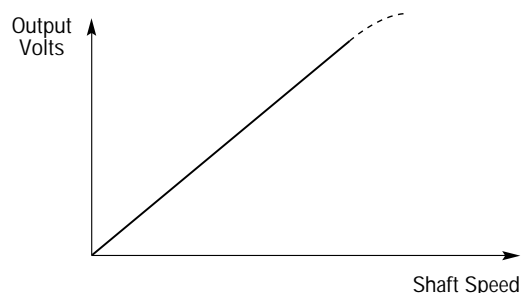
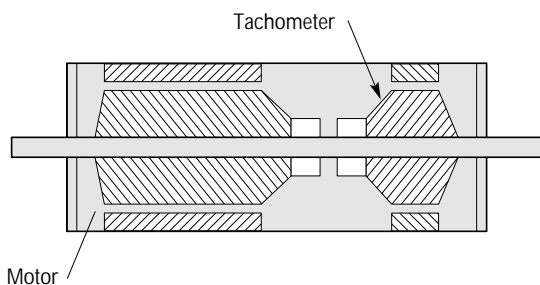

Fig. 4.2 Motor with integral tachometer



Optical Encoders

In servo control systems, where mechanical position is required to be controlled, some form of position sensing device is needed. There are a number of types in use: magnetic, contact, resistive, and optical. However, for accurate position control, the most commonly used device is the optical encoder. There are two forms of this encoder – absolute and incremental.

Optical encoders operate by means of a grating, that moves between a light source and a detector. When light passes through the transparent areas of the grating, an output is seen from the detector. For increased resolution, the light source is collimated and a mask is placed between the grating and the detector. The grating and the mask produce a shuttering effect, so that only when their transparent sections are in alignment is light allowed to pass to the detector (Fig. 4.3).

Fig. 4.3 Principle of optical encoder

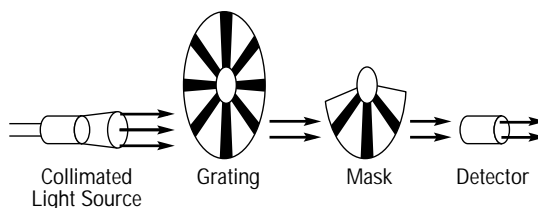

An incremental encoder generates a pulse for a given increment of shaft rotation (rotary encoder), or a pulse for a given linear distance travelled (linear encoder). Total distance travelled or shaft angular rotation is determined by counting the encoder output pulses.

An absolute encoder has a number of output channels, such that every shaft position may be described by its own unique code. The higher the resolution the more output channels are required.

The Basics of Incremental Encoders

Since cost is an important factor in most industrial applications, and resetting to a known zero point following power failure is seldom a problem, the rotary incremental encoder is the type most favored by system designers. Its main element is a shaft mounted disc carrying a grating, which rotates with the grating between a light source and a masked detector. The light source may be a light emitting diode or an incandescent lamp, and the detector is usually a phototransistor or more commonly a photo-voltaic diode. Such a simple system, providing a single low-level output, is unlikely to be frequently encountered, since quite apart from its low output signal, it has a DC offset that is temperature dependent, making the signal difficult to use (Fig. 4.4).

Fig. 4.4 Encoder output voltage

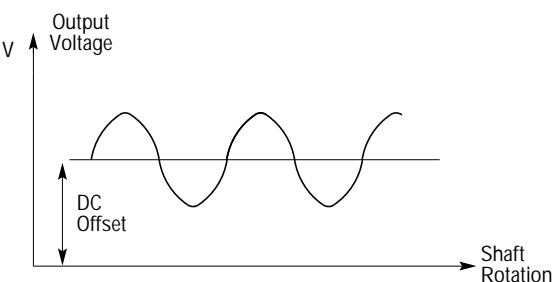

In practice, two photodiodes are used with two masks, arranged to produce signals with 180° phase difference for each channel, the two diode outputs being subtracted so as to cancel the DC offset (Fig. 4.5). This quasi-sinusoidal output may be used unprocessed, but more often it is either amplified or used to produce a square wave output. Hence, incremental rotary encoders may have sine wave or square wave outputs, and usually have up to three output channels.

Fig. 4.5 Output from dual photodiode system

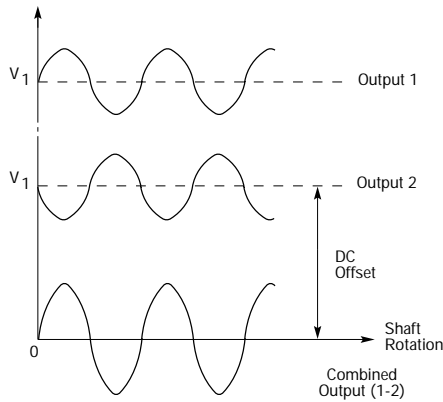

A two-channel encoder, as well as giving position of the encoder shaft, can also provide information on the direction of rotation by examination of the signals to identify the leading channel. This is possible since the channels are normally arranged to be in quadrature (i.e., 90° phase shifted: Fig. 4.6).

For most machine tool or positioning applications, a third channel known as the index channel or Z channel is also included. This gives a single output pulse per revolution and is used when establishing the zero position.

Fig. 4.6 Quadrature output signals

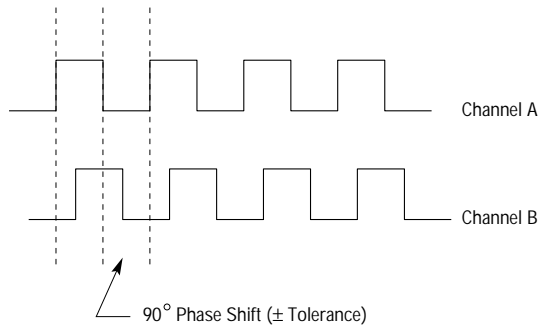

Fig. 4.6 shows that for each complete square wave from channel A, if channel B output is also considered during the same period, four pulse edges will occur. This allows the resolution of the encoder to be quadrupled by processing the A and B outputs to produce a separate pulse for each square wave edge. For this process to be effective, however, it is important that quadrature is maintained within the necessary tolerance so that the pulses do not run into one another.

Square wave output encoders are generally available in a wide range of resolutions (up to about 5000 lines/rev), and with a variety of different output configurations, some of which are listed below.

TTL (Transistor-Transistor Logic) – This is a commonly available output, compatible with TTL logic levels, and normally requiring a 5 volt supply. TTL outputs are also available in an open-collector configuration which allows the system designer to choose from a variety of pull-up resistor value.

CMOS (Complimentary Metal-Oxide Semiconductor) – Available for compatibility with the higher logic levels, it normally used with CMOS devices.

Line driver – These are low-output impedance devices designed for driving signals over a long distance, and are usually used with a matched receiver.

Complementary outputs – Outputs derived from each channel give a pair of signals, 180° out of phase. These are useful where maximum immunity to interference is required.

Noise problems

The control system for a machine is normally screened and protected within a metal cabinet. An encoder may be similarly housed. However, unless suitable precautions are taken, the cable connecting the two can be a source of trouble due to its picking up electrical noise. This noise may result in the loss or gain of signal counts, giving rise to incorrect data input and loss of position.

Fig. 4.7 Corruption of encoder signal by noise

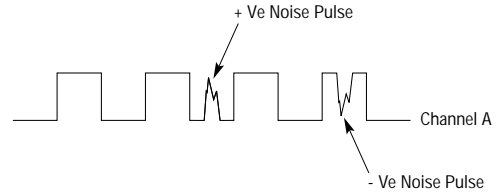

Fig. 4.7, shows how the introduction of two noise pulses has converted a four-pulse train into one of six pulses.

A number of techniques are available to overcome problems due to noise. The most obvious resolution is to use shielded interconnecting cables.

However, since the signals may be at a low level (5 volts) and may be generated by a high-impedance source, it may be necessary to go to further lengths to eliminate the problem.

The most effective way to resolve the problem is to use an encoder with complementary outputs (Fig. 4.8) and connect this to the control system by means of shielded, twisted-pair cable.

The two outputs are processed by the control circuitry so that the required signal can be reconstituted without the noise.

Fig. 4.8 Complementary output signals

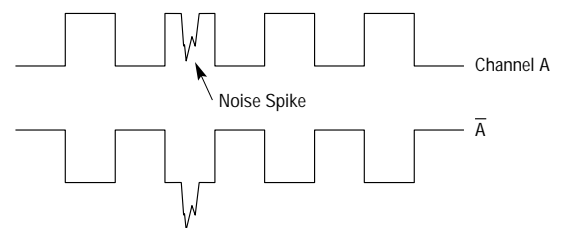

If the A signal is inverted and is fed with the A signal into an OR gate (whose output depends on one signal or the other being present), the resultant output will be a square wave (Fig. 4.9).

Fig. 4.9 Reduction of noise in a complementary system

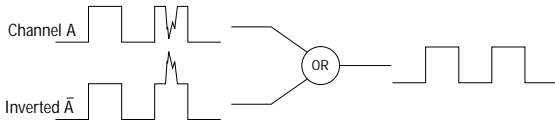

The simple interconnection of encoder and controller with channel outputs at low level may be satisfactory in electrically “clean” environments or where interconnections are very short. In cases where long interconnections are necessary or where the environment is “noisy”, complementary line driver outputs will be needed, and interconnections should be made with shielded, twisted-pair cable.

Factors Affecting Accuracy

Slew rate (speed) – An incremental rotary encoder will have a maximum frequency at which it will operate (typically 100KHz), and the maximum rotational speed, or slew rate, will be determined by this frequency. Beyond this, the output will become unreliable and accuracy will be affected.

Consider a 600-line encoder rotated at 1rpm (gives an output of 10Hz). If the maximum operating frequency of the encoder is 50KHz, its speed will be limited to 5000 times this (i.e., $50\text{KHz} \cdot 10\text{Hz} = 5000 \text{ rpm}$).

If an encoder is rotated at speeds higher than its design maximum, there may be conditions set up that will be detrimental to the mechanical components of the assembly. This could damage the system and affect encoder accuracy.

Quantization error – All digital systems have difficulty, interpolating between output pulses. Therefore, knowledge of position will be accurate only to the grating width (Fig. 4.10).

Fig. 4.10 Encoder quantization error

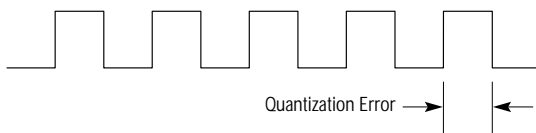

Quantization error = $F(1,2N)$ (N = # of lines/disk rotation)

Eccentricity

This may be caused by bearing play, shaft run out, incorrect assembly of the disc on its hub or the hub on the shaft. Eccentricity may cause a number of different error conditions.

a) **Amplitude Modulation** – In a sine wave encoder, eccentricity will be apparent as amplitude modulation (Fig. 4.11).

Fig. 4.11 Amplitude modulation caused by eccentricity

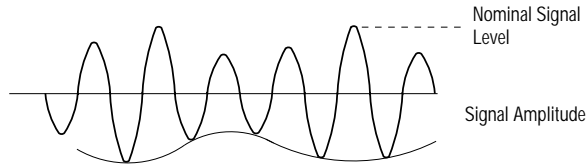

b) **Frequency modulation** – As the encoder is rotated at constant speed, the frequency of the output will change at a regular rate (Fig. 4.12). If viewed on an oscilloscope, this effect will appear as “jitter” on the trace.

Fig. 4.12 Encoder frequency modulation

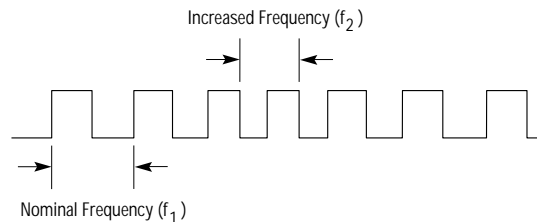

c) **Inter-channel jitter** – If the optical detectors for the two encoder output channels are separated by an angular distance on the same radius, then any “jitter” will appear at different times on the two channels, resulting in “inter-channel jitter”.

Environmental Considerations

Like electrical noise, other environmental factors should be considered before installing an optical encoder.

In particular, temperature and humidity should be considered (consult manufacturers’ specifications).

In environments contaminated with dust, oil vapor or other potentially damaging substances, it may be necessary to ensure that the encoder is enclosed within a sealed casing.

Mechanical Construction

Shaft encoder (Fig. 4.13). In this type of encoder, which may be either incremental or absolute, the electronics are normally supported on a substantial mounting plate that houses the bearings and shaft. The shaft protrudes from the bearings on the "outside" of the encoder, for connection to the rotating system, and on the "inside", so that the encoder disc may be mounted in the appropriate position relative to the light source and detector. The internal parts are covered by an outer casing, through which the interconnecting leads pass.

Fig. 4.13 Shaft encoder

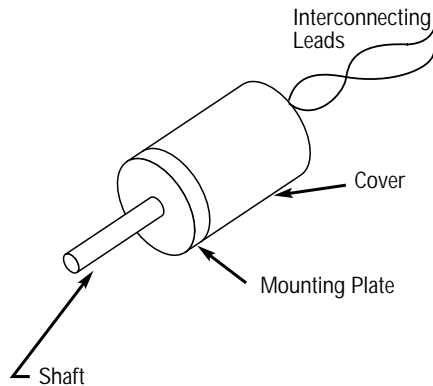

For use in extreme environmental or industrial conditions, the whole enclosure may be specified to a more substantial standard (heavy duty) with sealed bearings and sealing between the mounting plate and cover. Also the external electrical connections may be brought out through a high quality connector.

Modular or kit encoder (Fig. 4.14). These are available in a number of forms, their principal advantage being that of reduced cost.

Fig. 4.14 Modular encoder

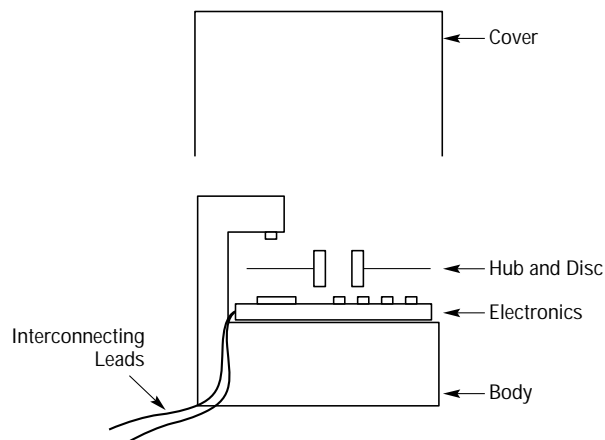

Since many servo motors have a double-ended shaft, it is a simple matter to fit a kit encoder onto a motor.

The kit encoder will usually be less robust than the shaft encoder, but this need not be a problem if the motor is mounted so that the encoder is protected. If this cannot be done, it will normally be possible to fit a suitable cover over the encoder.

A typical kit encoder will include a body, on which will be mounted the electronic components and a hub and disc assembly for fitting to the shaft. Some form of cover will also be provided, mainly to exclude external light and provide some mechanical protection.

Linear encoder. These encoders are used where it is required to make direct measurement of linear movement. They comprise a linear scale (which may be from a few millimeters to a meter or more in length), and a read head. They may be incremental or absolute and their resolution is expressed in lines per unit length (normally lines/inch or lines/cm).

Basics of Absolute Encoders

An absolute encoder is a position verification device that provides unique position information for each shaft location. The location is independent of all other locations, unlike the incremental encoder, where a count from a reference is required to determine position.

Fig. 4.15 Absolute disk



Fig. 4.16 Incremental disk



In an absolute encoder, there are several concentric tracks, unlike the incremental encoder, with its single track. Each track has an independent light source. As the light passes through a slot, a high state (true "1") is created. If light does not pass through the disk, a low state (false "0") is created. The position of the shaft can be identified through the pattern of 1's and 0's.

The tracks of an absolute encoder vary in slot size, moving from smaller at the outside edge to larger toward the center. The pattern of slots is also staggered with respect to preceding and succeeding tracks. The number of tracks determines the amount of position information that can be derived from the encoder disk – resolution. For example, if the disk has ten tracks, the resolution of the encoder would usually be 1,024 positions per revolution or 2^{10} .

For reliability, it is desirable to have the disks constructed of metal rather than glass. A metal disk is not as fragile, and has lower inertia.

Fig. 4.17 Absolute encoder output

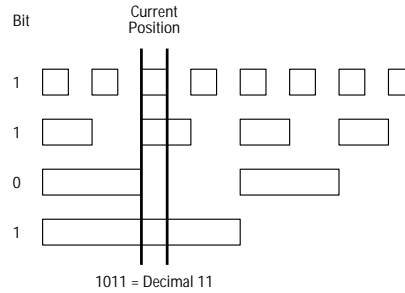

The disk pattern of an absolute encoder is in machine readable code, usually binary, grey code or a variety of grey. The figure above represents a simple binary output with four bits of information. The current location is equivalent to the decimal number 11. Moving to the right from the current position, the next decimal number is 10 (1-0-1-0 binary). Moving to the left from the current position, the next position would be 12 (1-1-0-0).

Fig. 4.18 Multi-turn absolute encoders

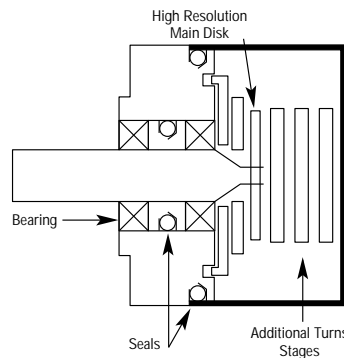

Gearing an additional absolute disk to the primary high-resolution disk provides for turns counting, so that unique position information is available over multiple revolutions.

Here is an example of how an encoder with 1,024 counts per revolution becomes an absolute device for 524,288 discrete positions.

The primary high-resolution disk has 1,024 discrete positions per revolution. A second disk with 3 tracks of information will be attached to the high-resolution disk geared 8:1. The absolute encoder now has 8 complete turns of the shaft or 8,192 discrete positions. Adding a third disk geared 8:1 will provide for 64 turns of absolute positions. In theory, additional disks could continue to be incorporated. But in practice, most encoders stop at or below 512 turns. Encoders using this technique are called multi-turn absolute encoders. This same technique can be incorporated in a rack and pinion style linear encoder resulting in long lengths of discrete absolute locations.

Advantages of Absolute Encoders

Rotary and linear absolute encoders offer a number of significant advantages in industrial motion control and process control applications.

No Position Loss During Power Down or Loss of Power

An absolute encoder is not a counting device like an incremental encoder, because an absolute system reads actual shaft position. The lack of power does not cause the encoder lose position information.

Whenever power is supplied to an absolute system, it can read the current position immediately. In a facility where frequent power failures are common, an absolute encoder is a necessity.

Operation in Electrically Noisy Environments
Equipment such as welders and motor starters often generate electrical noise that can often look like encoder pulses to an incremental counter. Electrical noise does not alter the discrete position that an absolute system reads.

High-speed Long-distance Data Transfer
Use of a serial interface such as RS-422 gives the user the option of transmitting absolute position information over as much as 4,000 feet.

Eliminate Go Home or Referenced Starting Point

The need to find a home position or a reference point is not required with an absolute encoding system since an absolute system always knows its location. In many motion control applications, it is difficult or impossible to find a home reference point. This situation occurs in multi-axis machines and on machines that can't reverse direction. This feature will be particularly important in a "lights-out" manufacturing facility. Significant cost savings is realized in reduced scrap and set-up time resulting from a power loss.

Provide Reliable Position Information in High-speed Applications

The counting device is often the factor limiting the use of incremental encoders in high-speed applications. The counter is often limited to a maximum pulse input of 100 KHz. An absolute encoder does not require a counting device or continuous observation of the shaft or load location. This attribute allows the absolute encoder to be applied in high-speed and high-resolution applications.

Resolvers

A resolver is, in principle, a rotating transformer. If we consider two windings, A and B (Fig. 4.19), and if we feed winding B with a sinusoidal voltage, then a voltage will be induced into winding A. If we rotate winding B, the induced voltage will be at maximum when the planes of A and B are parallel and will be at minimum when they are at right angles. Also, the voltage induced into A will vary sinusoidally at the frequency of rotation of B so that $E_{OA} = E_i \sin \theta$. If we introduce a third winding (C), positioned at right angles to winding A, then as we rotate B, a voltage will be induced into this winding and this voltage will vary as the cosine of the angle θ , so that $E_{OC} = E_i \cos \theta$

Fig. 4.19 Resolver principle

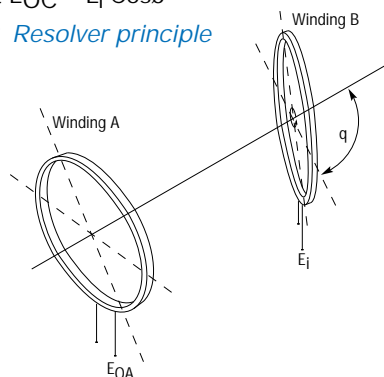

Referring to Fig 4.20, we can see that if we are able to measure the relative amplitudes of the two winding (A & C) outputs at a particular point in the cycle, these two outputs will be unique to that position.

Fig. 4.20 Resolver output

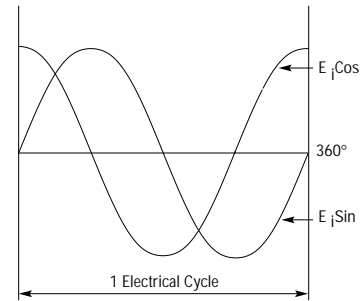

The information output from the two phases will usually be converted from analog to digital form, for use in a digital positioning system, by means of a resolver-to-digital converter (Fig. 4.21). Resolutions up to 65,536 counts per revolution are typical of this type of system.

Fig. 4.21 Resolver-to-digital converter

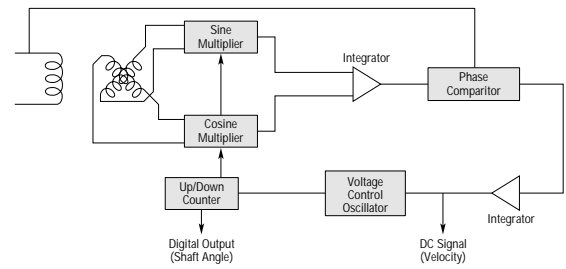

In addition to position information, speed and direction information may also be derived. The resolver is an absolute position feedback device. Within each electrical cycle, Phase A and Phase B maintain a constant (fixed) relationship.

The excitation voltage E_i may be coupled to the rotating winding by slip rings and brushes, though this arrangement is a disadvantage when used with a brushless motor. In such applications, a brushless resolver may be used so that the excitation voltage is inductively coupled to the rotor winding (Fig. 4.22).

Fig. 4.22 Brushless resolver

