

AN3216

Multilayer Chip Antenna for 2.4GHz Wireless Communication

AN3216 Multilayer Chip Antenna

◆ Features

- Miniaturized size 3.2(L)X1.6(W)X0.9(H)
- Light weight and low profile
- Omni-directional in azimuth

◆ Applications

- 2.4GHz wireless communications
- Modules
- Bluetooth
- 802.11b
- Other 2.4GHz Wireless Application



Specifications

Center frequency	2.45GHz
Peak gain	0.5dBi
Operation temperature	-40 ~ +85 °C
Storage temperature	-40 ~ +85 °C
VSWR	2.0 (Max)
Input Impedance	50 Ohm
Power handling	3W (Max)
Bandwidth	110MHz
Azimuth beamwidth	Omni-directional
Polarization	Linear
Solder pad	Natural tin

Pin configuration

1

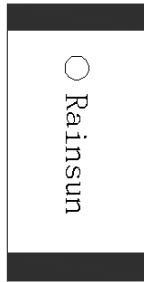

Pin No	Pin assignment
1	Feed termination
2	Solder termination

2

Dimensions

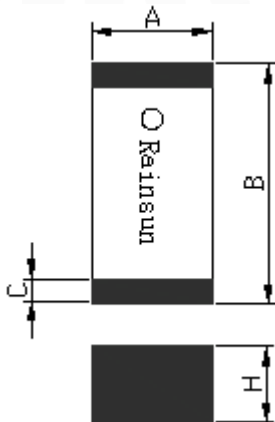

symbol	Dimensions(mm)
A	1.6±0.1
B	3.2±0.1
C	0.3±0.02
H	0.9±0.1

PCB Foot Printer

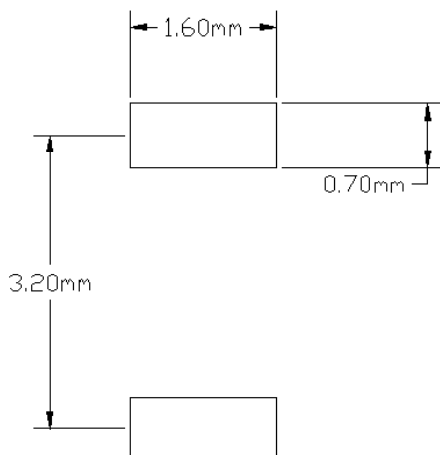

Recommend Test Board Pattern

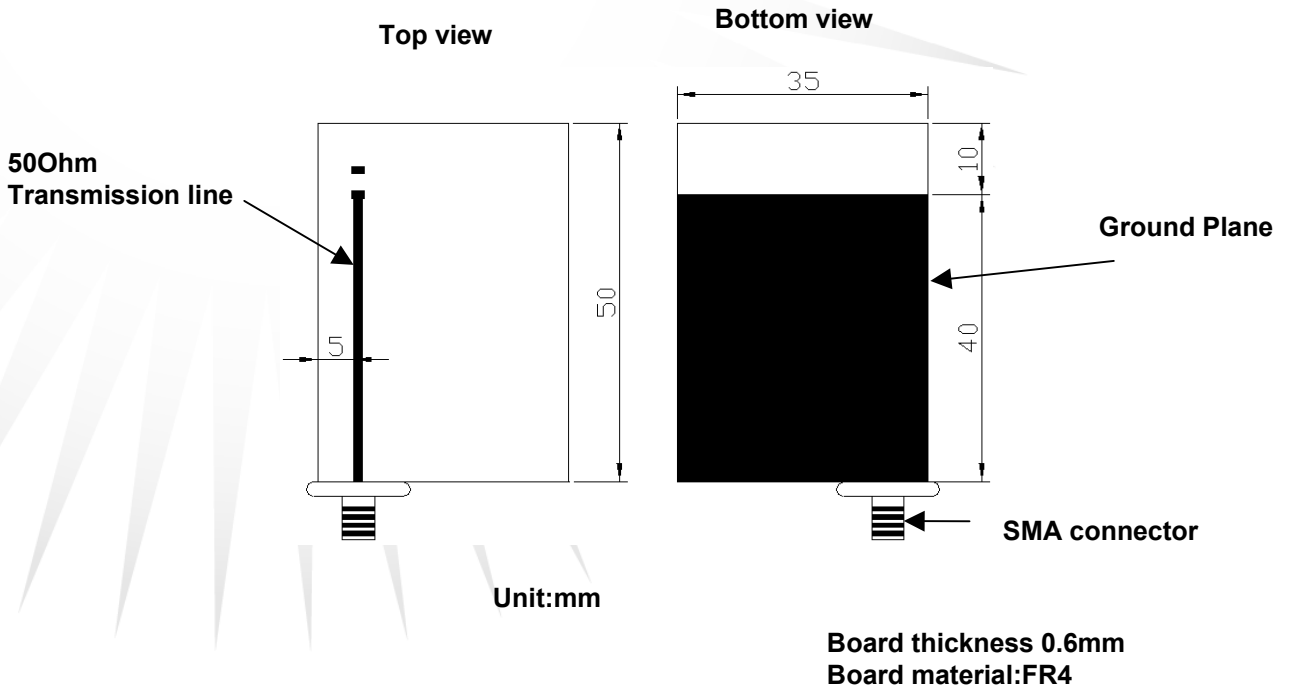

Testing Block

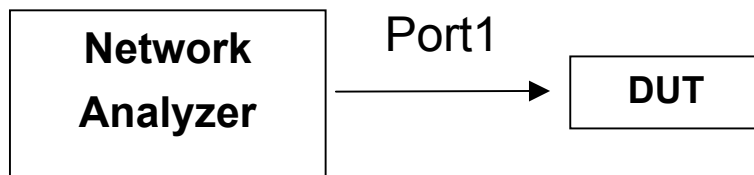

Measurement



Testing Instrument: Anritsu 37369C VNA(Vector Network Analyzer)

VNA calibrate with 1 path reflection only calibration sequence on test board feed point. The test board layout as recommend dimension.

Measured Antenna patterns

Return loss

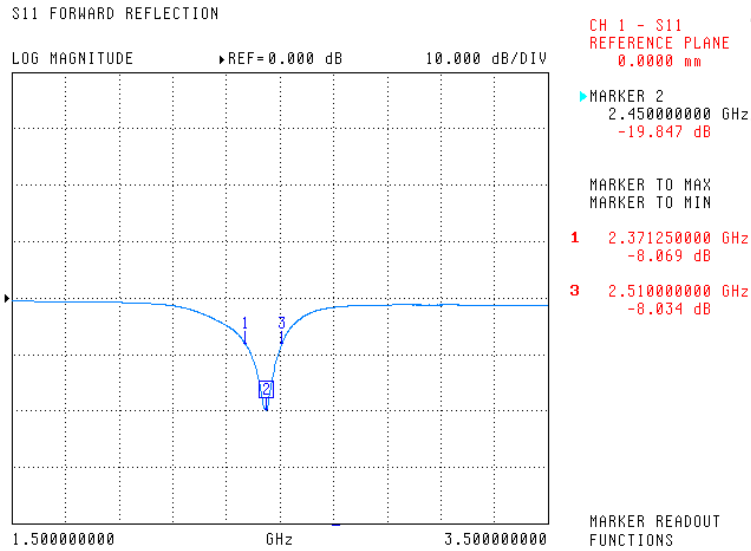

Smith Chart

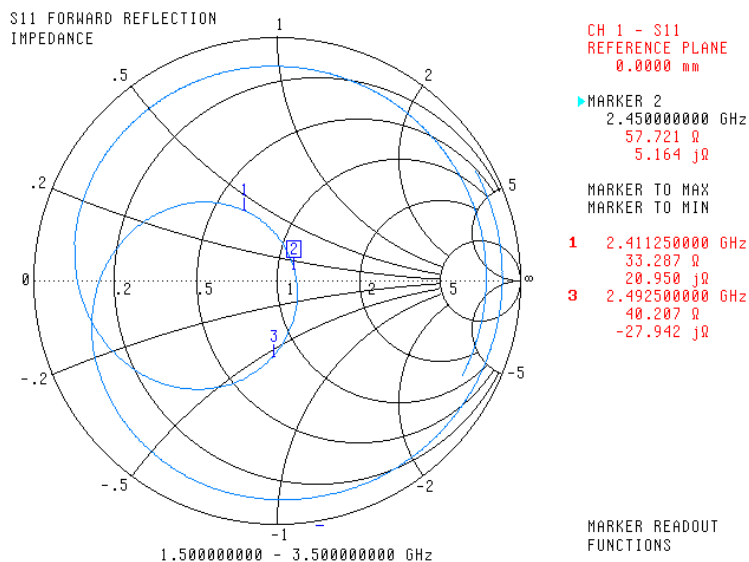

Radiation Pattern Scanning

**2.45 GHz H-Plane
vertical**

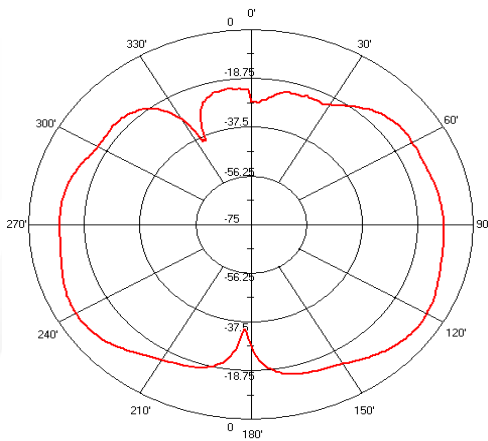

**2.45 GHz H-Plane
horizontal**

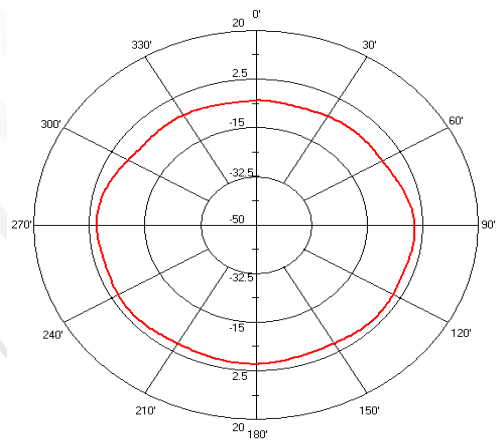

**2.45 GHz E-Plane
vertical**

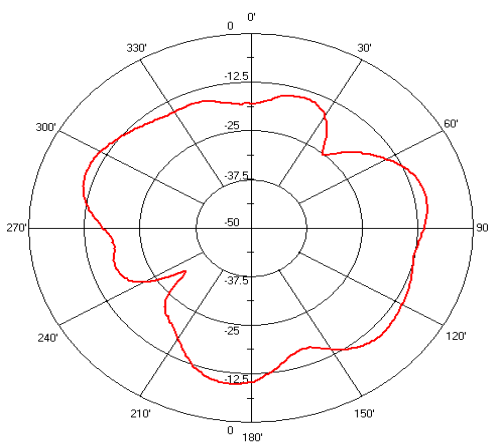

**2.45 GHz E-Plane
horizontal**

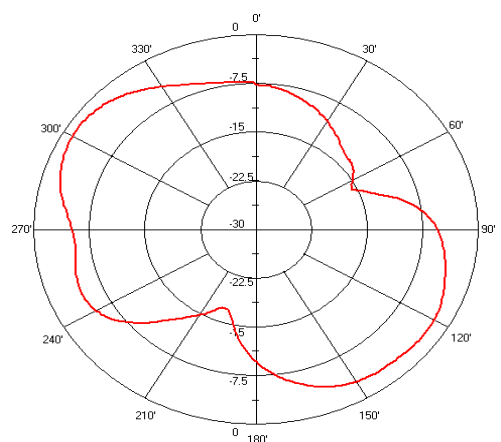

Solder the temp picture of pad

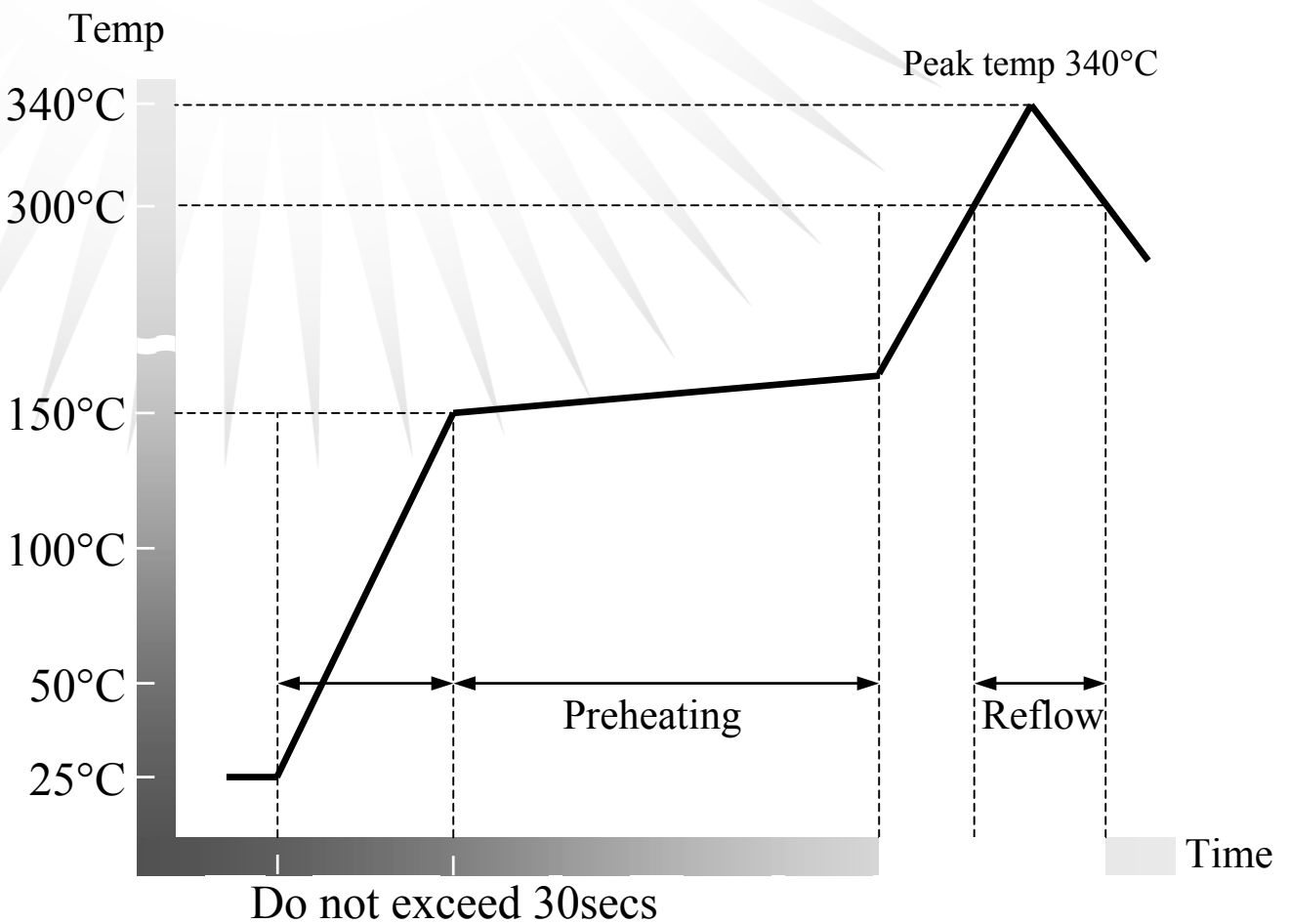

Blister Tape

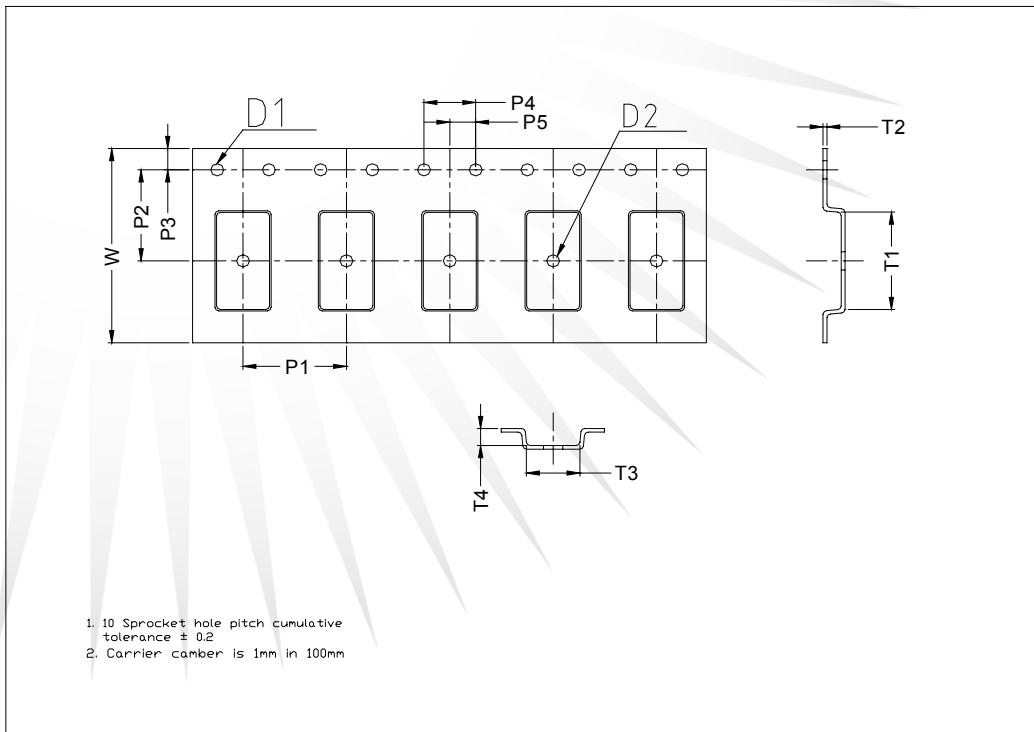

Symbol	W	P1	P2	P3	P4	P5
Dimension	8.0 ± 0.3	4.0 ± 0.1	4.0 ± 0.1	1.5 ± 0.1	5.0 ± 0.1	2.0 ± 0.1
Symbol	D1	T1	T2	T3	T4	
Dimension	1.5 ± 0.1	3.79 ± 0.1	0.22 ± 0.05	2.29 ± 0.1	1.0 ± 0.1	

Dimensions in mm

Reel

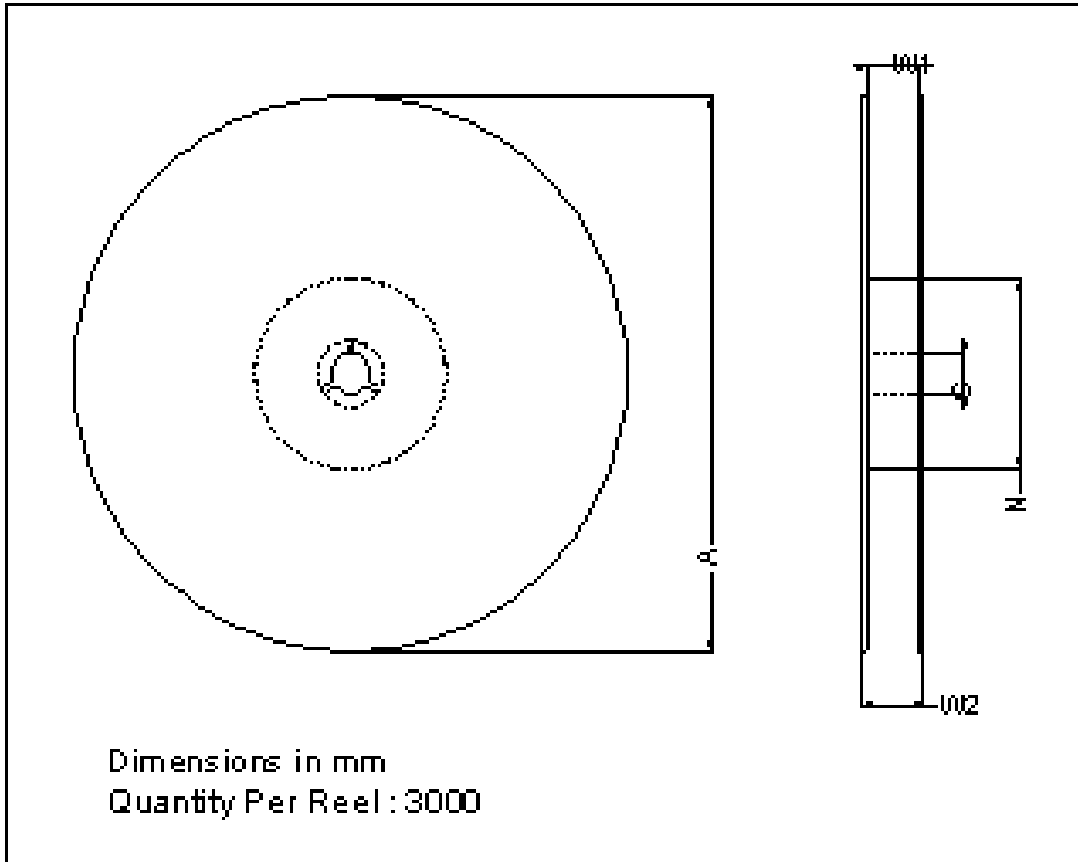

Symbol	A	C	N	W1	W2
Dimension	175.3±0.1	12.73±0.5	56.04±0.1	8.48±0.2	11.0±0.2

Dimensions in mm

Put the sketch map of purpose

