



Understanding the Output Current Capability of DC-DC Buck Converters

Prepared by: Upal Sengupta
ON Semiconductor
Principal Field Applications Engineer

APPLICATION NOTE

INTRODUCTION

Due to the widespread availability of highly integrated DC-DC switchmode converter devices, system design engineers no longer have to put much effort into the design of low-power converters for many applications. A little bit of analysis, however, can allow the system designer to make sure that an IC switching regulator is being utilized to its full capability.

Whether a DC-DC converter circuit uses an internal or external power switch, one critical parameter that the circuit designer must determine is the load current capability. This value leads to the sizing of the power switch. The peak switch current rating (the level of current above which the power MOS device may break down or overheat) is proportional to the load current. Of course, a larger power MOS device will be able to deliver more output current, but for a given switch current rating, the system designer does have some ability to affect output current capability based on external component values and operating conditions as well.

In addition to the peak switch current limit rating, the effective output current capability for the overall power supply circuit also depends on the input-output voltage

relationship, the inductor value, and switching frequency. As a result, system designers need to understand how the specifications of an IC switching regulator should be interpreted to apply to their specific operating conditions. In some cases, the published output current ratings of the IC may not reflect the true capability of the part for a given application, whereas in other cases the safe operating limits of the IC may be inadvertently exceeded.

Buck Converter Topology

A “semi-ideal” synchronous buck converter is illustrated in Figure 1. The high-side power switch duty-cycle will depend on the step-down ratio. When the high-side power switch is turned on, current drawn from the input begins to flow through the inductor. When the high-side switch is turned off, the low-side (synchronous rectifier) switch is turned on, and current circulates through the lower NMOS switch as shown, since the inductor current cannot instantaneously stop. During steady-state operation, the “on” and “off” times of the switch are balanced to maintain the desired output voltage.

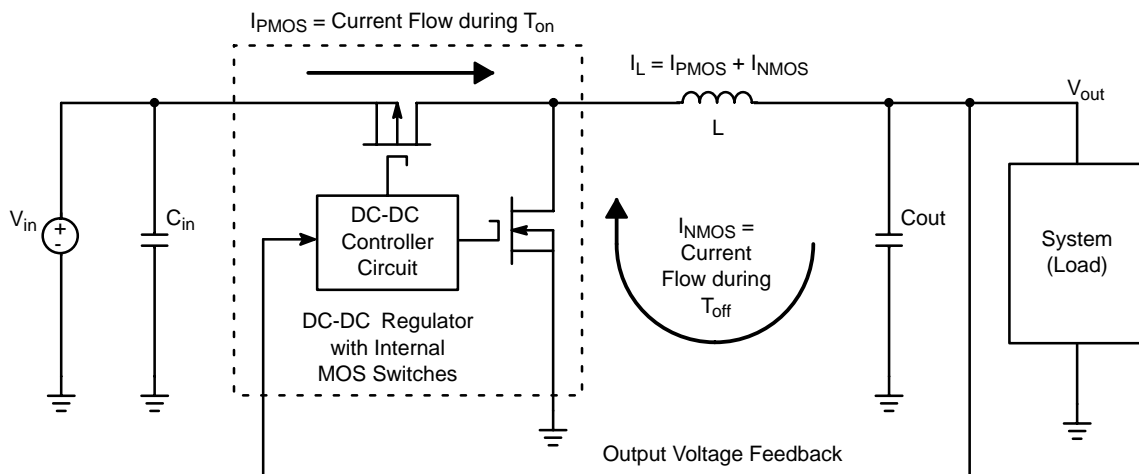

Figure 1. “Semi-Ideal” Synchronous Buck Regulator

When operating in continuous conduction mode, the PMOS (high-side) switch has a duty cycle proportional to the step-down ratio,

$$D = V_{out}/V_{in}$$

For a switching frequency f_s , the on-time of the PMOS switch will be:

$$T_{on} = D * (1/f_s)$$

Thus, the T_{on} is dependent on both the switching frequency and the step-down ratio.

Inductor Current Waveforms and Equations

Since the objective of this discussion is to characterize the full-load operation of the DC-DC converter, we can assume that the converter will be operating in continuous conduction mode (CCM). In CCM operation, the inductor current stays above zero as shown in Figure 2.

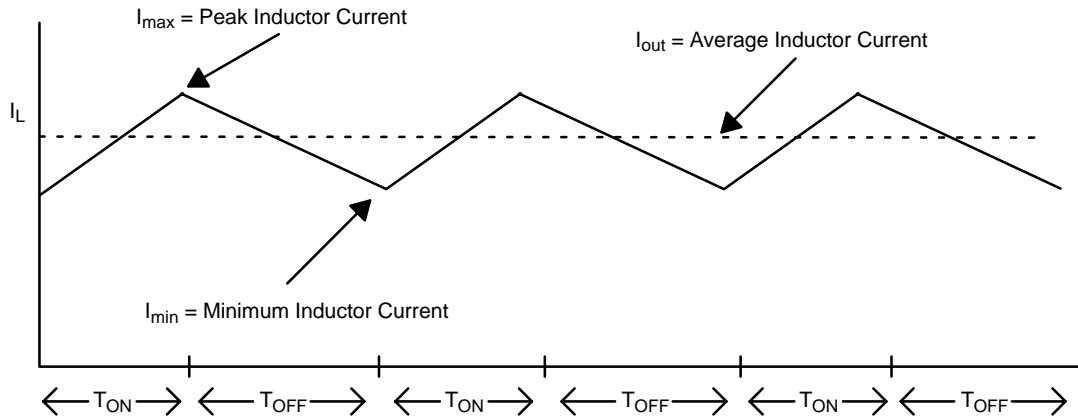

Figure 2. Inductor Current in Continuous Conduction Mode

The average inductor current is equal to the output (load) current. For a given constant load level, the inductor current will be ramping above and below this level as the power switch is turned on and off. Thus the peak inductor current, and therefore the peak high-side power switch current, will be higher than the output current. The output current is the average value of the inductor current, which varies between I_{min} and I_{max} :

$$I_{out} = (I_{min} + I_{max})/2 \quad (\text{for CCM only})$$

To determine the actual peak switch current value for a given load current, we can begin with the familiar equation for the inductor voltage/current relationship:

$$V = L * (di/dt)$$

In our case, “V” is the differential voltage across the inductor, or $(V_{in} - V_{out})$ when the high-side power switch is turned on. The change in inductor current “di” from the initial turn-on of the PMOS switch until it is turned off is $(I_{max} - I_{min})$. Finally, the “dt” value is the switch on-time, T_{on} as defined earlier. Thus the inductor voltage-current relationship can be defined as:

$$(V_{in} - V_{out}) = L * (I_{max} - I_{min})/(T_{on})$$

Rearranging terms results in:

$$(I_{max} - I_{min}) = (V_{in} - V_{out}) * (T_{on})/L$$

and since we know $I_{out} = (I_{min} + I_{max}) / 2$, as seen in Figure 2, we can substitute for I_{min} in terms of I_{out} and determine the upper limit of the inductor ramp current to be:

$$I_{max} = I_{out} + (V_{in} - V_{out}) * (T_{on})/(2L)$$

The $\{(V_{in}-V_{out})*T_{on}/(2L)\}$ term above represents half of the peak-to-peak ripple current. Because the value for I_{max} is limited to the high-side power switch current rating, reducing the ripple current (the difference between the peak inductor current and the average load current) allows the effective output current of the circuit to approach the switch current rating. The equation above indicates the following general trends for a buck converter circuit:

- Higher inductance allows higher load current for a fixed frequency (larger L = reduced ripple current)
- Higher frequency allows higher load current for a fixed inductance level (smaller T_{on} = reduced ripple current)
- V_{in}/V_{out} levels affect the output current in two opposing ways:
 - Higher step-down ratio (V_{out}/V_{in}) results in shorter switch on-time (T_{on}), hence lower peak switch current
 - Lower step down ratio (V_{in} closer to V_{out}) results a lower differential inductor voltage, so the slope of the inductor current during the ramp-up period is reduced

NCP1501 Synchronous Buck Regulator

From a system designer's point of view, the NCP1501 device in Figure 3 may appear similar to the "semi-ideal" buck converter. The only external components required are an input capacitor, output inductor, and output capacitor.

The additional features of the NCP1501 regulator allow for external frequency input, shutdown mode, output voltage selection, and high efficiency at both high and low load currents. These features are discussed in the device data sheet and will not be covered in this note.

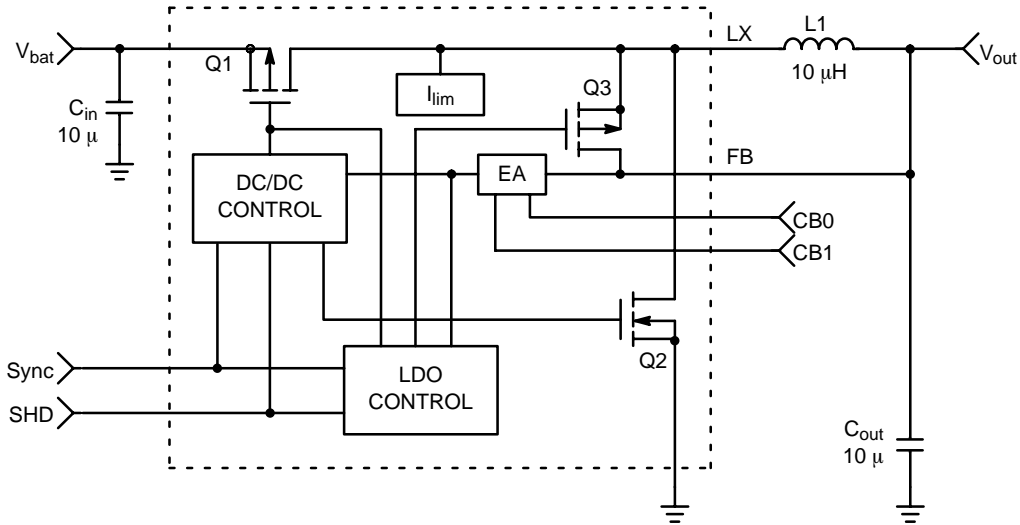

Figure 3. NCP1501 Block Diagram and Application Circuit

Calculation of the peak current equations as applied to the NCP1501 device show that the effective output current of the device can indeed vary as a function of external components and operating conditions. The peak switch current limit for the PFET (Q3 as shown in Figure 3) is nominally 800 mA. To

allow for component tolerances, a 20% derating of the typical value gives us 640 mA, which is used for a minimum limit.

Figures 4 and 5 illustrate the difference in output current capability for a 4.2 V- to- 1.8 V converter using the NCP1501 by adjusting frequency and/or inductor value.

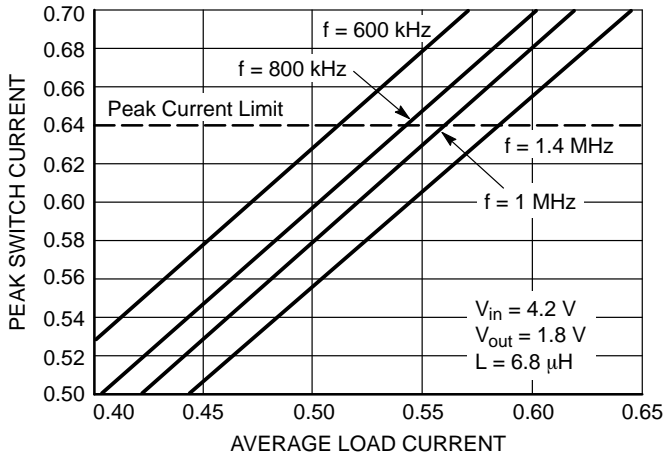

Figure 4. Output Current, L = 6.8 μH

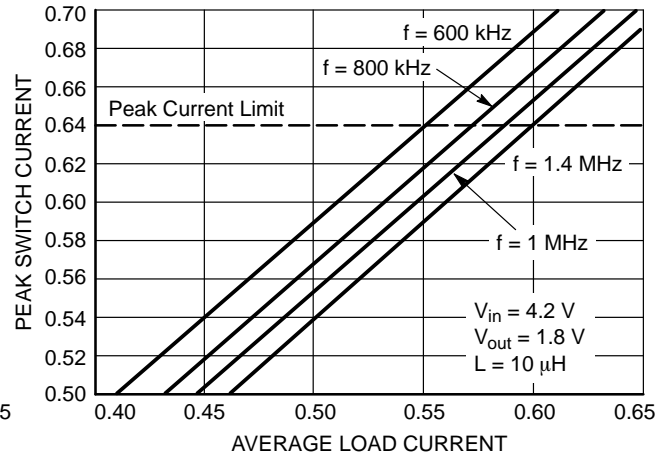

Figure 5. Output Current, L = 10 μH

AND8117/D

At 600 kHz operating frequency, with a 6.8 μH inductor, the converter can only deliver about 500 mA before the worst-case switch rating is reached. However, if the switching frequency is increased to 1.4 MHz for the same inductor value, over 550 mA output capability is possible. By increasing the inductor to 10 μH , the load current can be pushed to above 600 mA. The NCP1501 allows the user to select the switching frequency by applying an external clock signal.

Figure 6, on the other hand, shows the effect of input voltage on output current capability for a fixed operating frequency (1.0 MHz) and inductor value (6.8 μH). In this case, if the input voltage is restricted, output current capability may be increased. However, if the full input voltage range is required, the system designer should be aware that the worst case current rating for the power switch will be reached at lower levels of load current for high input voltage conditions.

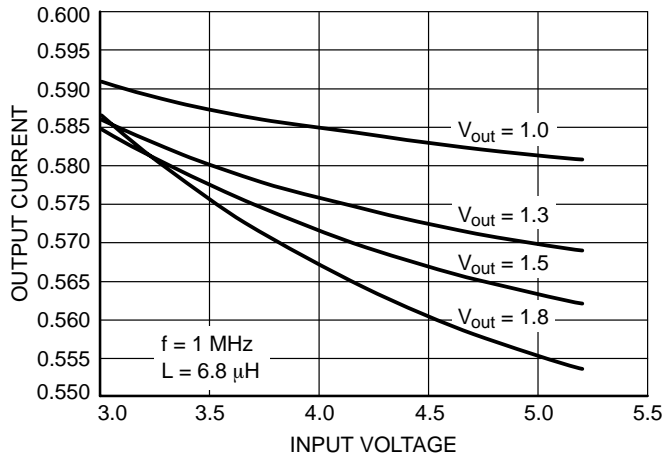

Figure 6. NCP1501 Output Current Variation with Input and Output Voltage

This phenomenon may seem somewhat counterintuitive as one thinks of high line input requiring less current from the input power source - however, due to the higher input-output differential, the inductor current ramps up very quickly in this condition so the ripple current is higher.

The actual line and load regulation performance of the NCP1501 device, operating at 1.0 MHz with a 6.8 μH inductor (TDK LLF40176R8), is shown in Figure 7.

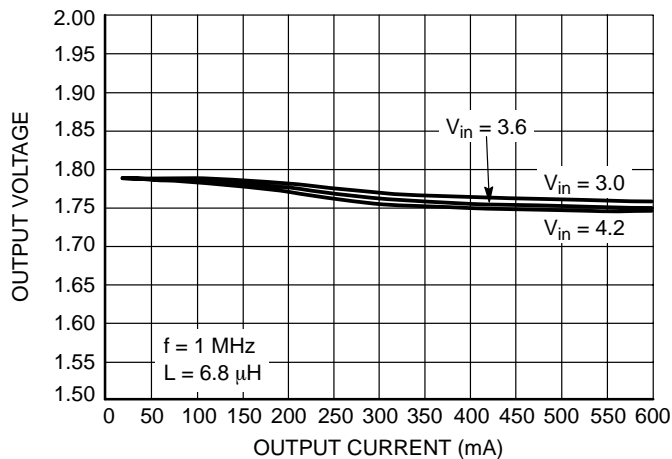

Figure 7. NCP1501 Output Performance for 3.0 - 4.2 V Input Range (PWM Mode)

Final Observations . . .

It may seem from the above discussion that one would simply go with the largest possible inductor and highest possible frequency in order to maximize output current capability. In reality, though, compromises must be made due to other considerations. For example, larger inductance values will typically require a larger physical case dimension for the same saturation current capability. Component tolerances and derating factors also need to be taken into account, as magnetic components will start to decrease in effective inductance value as current increases toward the saturation limit. Larger inductances will slow down the response time of the switching regulator when subjected to line and load transient conditions. Furthermore, since the NCP1501 is designed to require a minimum amount of external components, the control loop stability compensation circuit is completely internal to the IC. This also limits the range of values allowed for the output inductor and capacitor.

Thus, for applications where space is at a premium, the system designer may instead choose to go with the lowest

possible inductor value that will reliably provide “just enough” output current to the load. Furthermore, higher switching frequencies will result in higher switching losses. In the particular case of the NCP1501, this translates into a few percentage points lower converter efficiency. This, of course, results in slightly reduced battery life for a portable device. Higher frequency operation may also restrict the choice of inductors due to the need for magnetic core materials that maintain their performance characteristics at high dV/dT conditions.

The 640 mA minimum switch current rating of the NCP1501 device allows easy design of a converter with 500 to 600 mA output current capability, using standard surface-mount components. While today’s integrated switchmode regulators are substantially easier to use in a system design than their predecessors were, proper external component selection is still critical in order to achieve best performance.

A table of possible component values is listed below.

Inductor	Description
TDK LLF4017-6R8 (6.8 μ H)	DCR = 0.122 Ω , Ipk = 0.70 A, 4.0x4.1x1.7 mm
TDK LLF4017-100 (10 μ H)	DCR = 0.145 Ω , Ipk = 0.50 A, 4.0x4.1x1.7 mm
Coilcraft DO1606T-682 (6.8 μ H)	DCR = 0.2 Ω , Ipk = 1.0 A, 6.5x5.3x2.0 mm
Coilcraft DO1606T-103 (10 μ H)	DCR = 0.3 Ω , Ipk = 1.0 A, 6.5x5.3x2.0 mm
Coilcraft LPO6610-682 (6.8 μ H)	DCR = 0.32 Ω , Ipk = 0.90 A, 5.5 x 6.6 x 1.0 mm

Capacitor	Description
TDK C2012X5R0J106 (10 μ F)	ESR = 2.3 m Ω , I _{rms} = 3.5 A @ 1.0 MHz, 2.0x1.25x1.25 mm
μ Rata GRM21BR60J106 (10 μ F)	ESR = 2.0 m Ω , I _{rms} = 1.7 A @ 1.0 MHz, 2.0x1.25x1.25 mm

ON Semiconductor and  are registered trademarks of Semiconductor Components Industries, LLC (SCILLC). SCILLC reserves the right to make changes without further notice to any products herein. SCILLC makes no warranty, representation or guarantee regarding the suitability of its products for any particular purpose, nor does SCILLC assume any liability arising out of the application or use of any product or circuit, and specifically disclaims any and all liability, including without limitation special, consequential or incidental damages. "Typical" parameters which may be provided in SCILLC data sheets and/or specifications can and do vary in different applications and actual performance may vary over time. All operating parameters, including "Typicals" must be validated for each customer application by customer's technical experts. SCILLC does not convey any license under its patent rights nor the rights of others. SCILLC products are not designed, intended, or authorized for use as components in systems intended for surgical implant into the body, or other applications intended to support or sustain life, or for any other application in which the failure of the SCILLC product could create a situation where personal injury or death may occur. Should Buyer purchase or use SCILLC products for any such unintended or unauthorized application, Buyer shall indemnify and hold SCILLC and its officers, employees, subsidiaries, affiliates, and distributors harmless against all claims, costs, damages, and expenses, and reasonable attorney fees arising out of, directly or indirectly, any claim of personal injury or death associated with such unintended or unauthorized use, even if such claim alleges that SCILLC was negligent regarding the design or manufacture of the part. SCILLC is an Equal Opportunity/Affirmative Action Employer.

PUBLICATION ORDERING INFORMATION

Literature Fulfillment:

Literature Distribution Center for ON Semiconductor
P.O. Box 5163, Denver, Colorado 80217 USA
Phone: 303-675-2175 or 800-344-3860 Toll Free USA/Canada
Fax: 303-675-2176 or 800-344-3867 Toll Free USA/Canada
Email: ONlit@hibbertco.com

N. American Technical Support: 800-282-9855 Toll Free USA/Canada

JAPAN: ON Semiconductor, Japan Customer Focus Center
2-9-1 Kamimeguro, Meguro-ku, Tokyo, Japan 153-0051
Phone: 81-3-5773-3850

ON Semiconductor Website: <http://onsemi.com>

For additional information, please contact your local Sales Representative.