

Crystal Radio

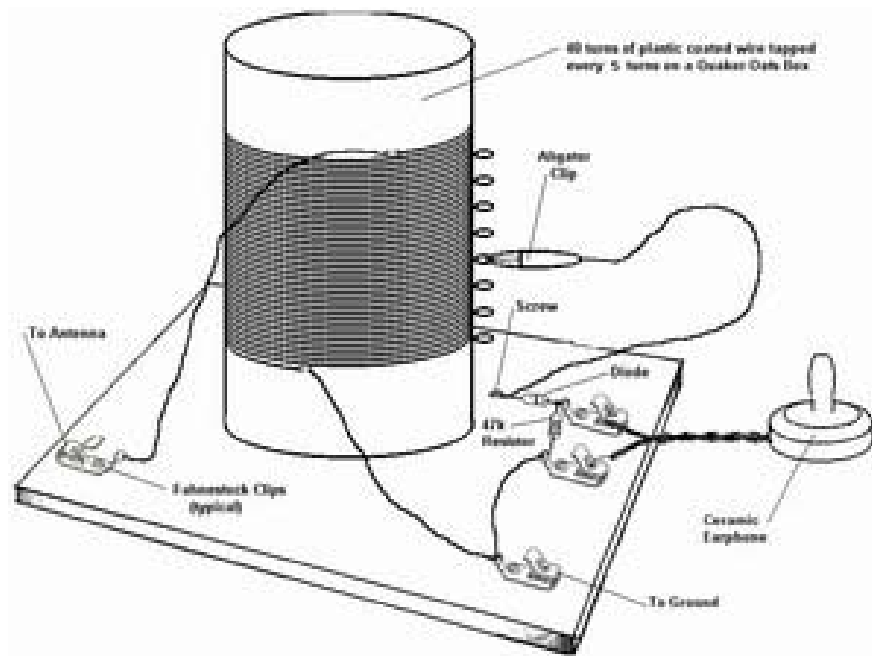

Crystal Radio

Abstract

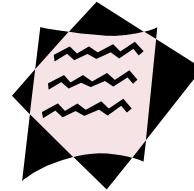

Students learn the principles of radio waves by building a crystal radio.

Equipment

1. Antenna
2. Copper Wire
3. Tank Circuit
4. Plastic Insulation
5. Detector
6. Germanium Semiconductor Crystal
7. Earphone
8. Piezoelectric Device



Grade Level



This activity is suitable for Elementary and Middle School Students.

State Standards Met

Standard 1 – Analysis, Inquiry, and Design
Standard 4 – Physical Setting and Living Environment

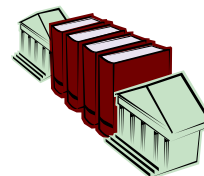

Build a Crystal Radio

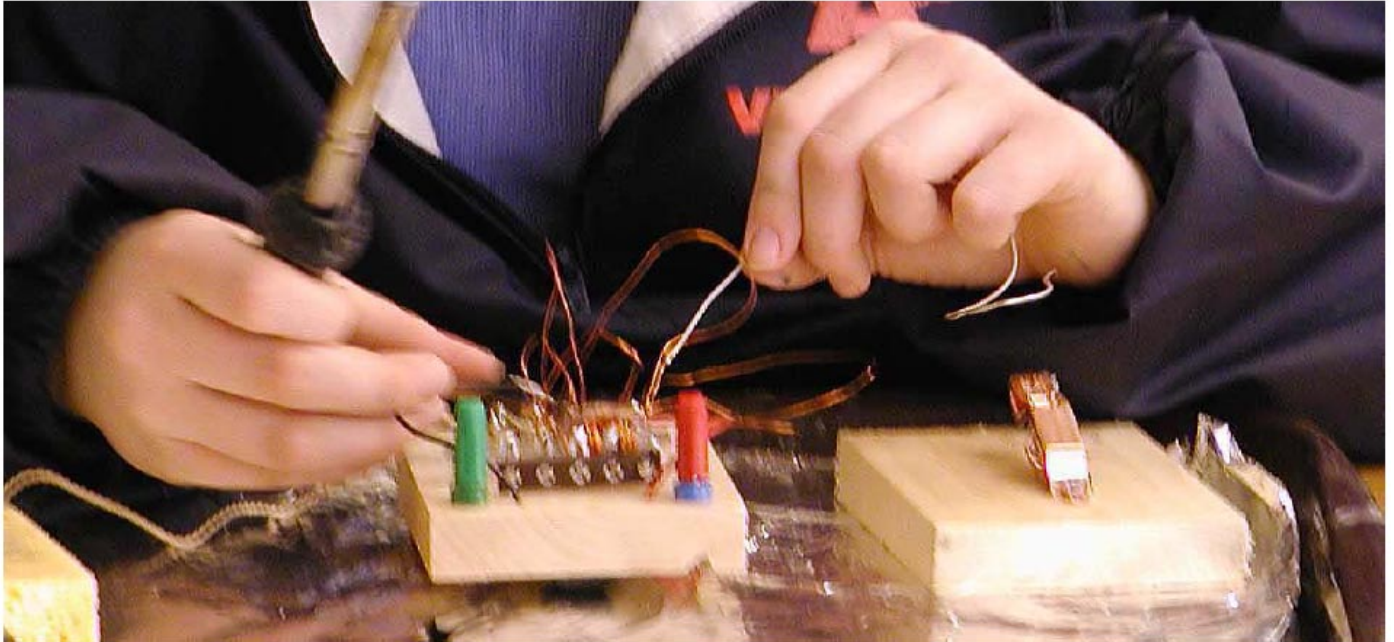

This program is supported by:
the Cornell Center for Materials Research,
and
the National Science Foundation



Support for the Cornell Center for Materials Research is provided through the National Science Foundation as part of the Materials Research Science and Engineering Centers (MRSEC) program. Additional support is provided by Cornell University.

Make Your Own Crystal Radio!

Here at the Cornell University Center for Materials Research Radio Factory you'll make your own radio wave powered crystal radio set. You'll learn a lot about how your radio works and the special materials that you'll use to make it go. You'll also gain some valuable electronics construction skills such as the ability to recognize components and join them together by soldering.

How Your Radio Will Work

Here is a chart that shows how signals flow through the four different sections of the radio and are changed along the way.

In this chart we say a bit about what each section does, give its official radio builders name, and introduce a special material that is needed for the section to work

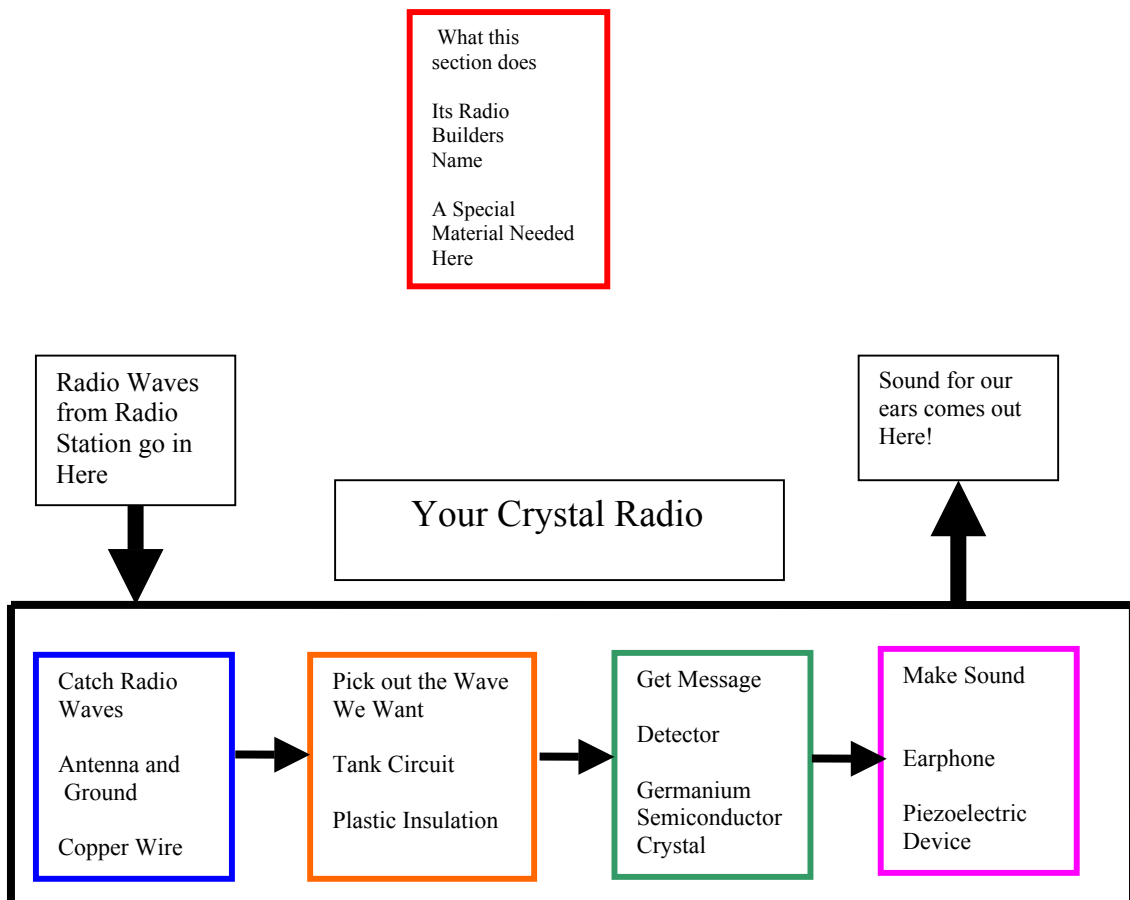

Here's what the different sections in the radio do and the role the special materials play.

1) Catch Radio Waves:

The radio stations launch electric and magnetic forces through space that come and go a million times in a second. These electromagnetic vibrations are not always the same. In fact, the radio station changes their strength much more slowly, thousands of times per second to carry the messages in the form of words or music that they wish us to hear. You can send your voice a whole lot further by getting it to ride a radio wave than by simply yelling. For our radio wave catcher we can often use large pieces of metal that readily pass electricity. Things that pass electricity well are called conductors. We use electric forces in the radio waves to set electric current moving back and forth in time to the wave in the copper metal wires (more good conductors) that connect our radio at the antenna and ground connections. We need the material copper metal to bring these currents to the radio. Radio builders call the antenna the conductor that catches the wave in space. It can be the wire that comes with your set alone or a piece of metal such as an air duct. The ground is a connection to earth that allows the desired electric currents to pass from the antenna and through your radio. When running a home crystal set one can frequently use a cold water pipe, so long as it's made out of a metal (often copper). The "ground" doesn't have to actually be connected to the earth. When we look for a good antenna and ground combination, what we are really seeking are two large conductors that are appropriately shaped and oriented (that means trying to see what works!) and are not already connected to each other. We can then hook up your radio between them (one side to the antenna connection, the other side to the ground connection) and catch the radio wave currents that pass back and forth between them. Please pay attention to avoid connecting your radio to power lines. I can't warn you enough about how dangerous that is. There are lots more ideas about making good antenna and ground connections later in these notes.

To keep from losing our radio signal, we prevent wires we don't want connected from touching with the colored plastic around them. Things that won't allow electricity to pass through them, like the plastic, are called insulators. You'll need many forms of insulators in your radio. See if you and your instructor can find some.

2) Pick out the Wave We Want: Just as a swing swings best when we pump it at the right rate, the tank circuit composed of the coil and a capacitor will set an electric current sloshing back and forth if they are tuned for the right station. Around Ithaca, WTKO vibrates waves at 1,470,000 times a second and WHCU vibrates waves at 870,000 times a second. By adjusting the tank circuit to the right rate of electric vibration we not only select the station we want, but it is made stronger, just the reason we pump a swing at the right rate to make it swing well. To tune our tank circuit we change the size of the variable capacitor by adjusting the black tuning knob, just like in a regular radio. In the tank circuit the radio energy is swapped back and forth between the coil where it is stored as a magnetic field and the capacitor where it's in the form on an electric field. The vibrations are managed in exactly this energy exchange process. The corresponding

process in a swing is to exchange energy of motion (greatest when you are swing through the low point) and energy in a gravity field (greatest when you are at the high points). When we want to store energy in a magnetic field, we use turns of metal wire to flow electricity in a loop. In the capacitor, we also use metal, but as plates that are close to each other, but not touching. We keep them from touching by using plastic insulation. That's a special material needed for the tank circuit. See if you can spot the metal/plastic sandwiches in the capacitor. Can you see what happened inside the capacitor when you turn the tuning knob?

3) Get the Message: To pull the message of music or speech off the vibrating current from the tank circuit is the neatest trick of all. This happens in the detector stage. This accomplished by our most special material: the germanium crystal diode. This is why our radio is called a crystal radio. Germanium, like so many materials that are at the heart of today's radio, TV's, electronics toys and computers, is a material that conducts electricity much more than an insulator, but not as well as a metal. Our crystal diode has a special property that is essential for pulling the message off the vibrating current: it passed current better one way than in the opposite direction. This allows the slow changes in the vibration that contains the electrical signals containing music or speech messages to be detected.

We can explain this in detail as follows: following the tuner stage, the radio uses a germanium diode to extract the audio signal from the much higher frequency radio wave that has carried it to this point. Since this signal is coded in the form of strength variations of the radio frequency wave, the detector acts in an analogous manner to the DC power supplies that have as their input the AC line voltage in a house. The principle it uses to extract the audio wave is to act as a one-way valve for electric current. Rather than confront the earphone of the last stage with an AC voltage that swings too fast by equal amounts toward positive and negative voltages (besides which, our ears would not detect such rapid variations anyway) the diode passes current in only one direction. Once smoothed by the earphone circuitry, this wave appears as immediately recognizable sounds. To repeat, the diode pulls the audio message off the radio wave that carried it great distances by passing its rapidly oscillating current in only one direction. The resultant signal is then smoothed in the last stage into a slowly varying wave. If we had admitted both directions of current flow, successive swings of the radio wave would have cancelled each other out during smoothing.

Can you think of other things at home that need to do tricky electrical transformations to do their job?

4) Make Sound: The last step is to turn the electric currents representing speech or music back into sound that we can hear. Our earphone does this. It uses another special material that has the property of being piezoelectric: when we apply electricity to it, it changes its size a little bit. But that's enough to make the air around it move to form a sound wave that we can hear.

I'll bet you know other devices that we use all the time to make electrical currents into sound. What about the other way around?

One of the neatest features of your radio is that it gets all its power from the radio wave itself. It does all these jobs without being plugged into the wall or using a battery.

Here are a couple of views of one way to build your radio. The different sections are outlined in the second view to indicate by color the four main parts of the radio.

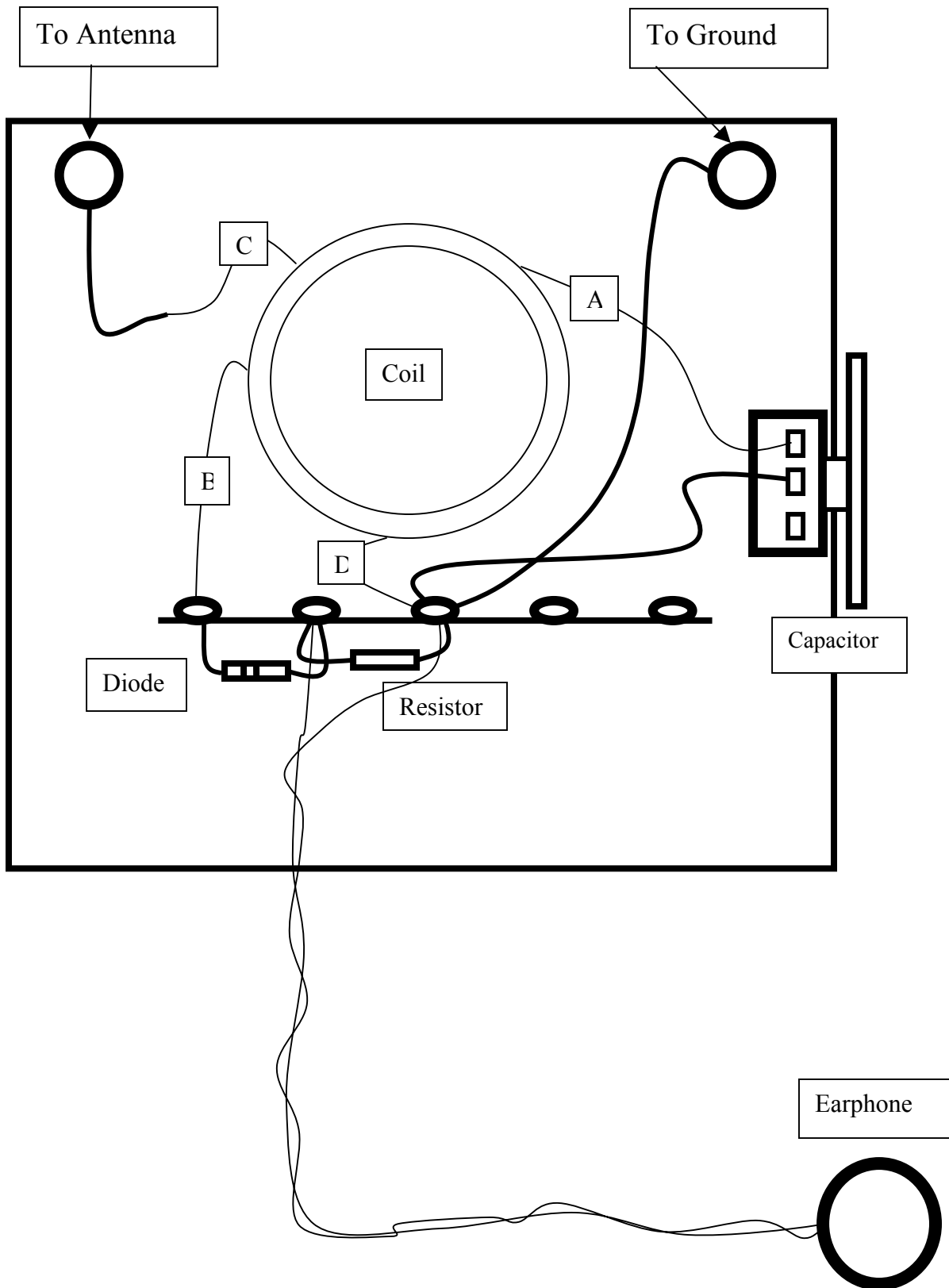

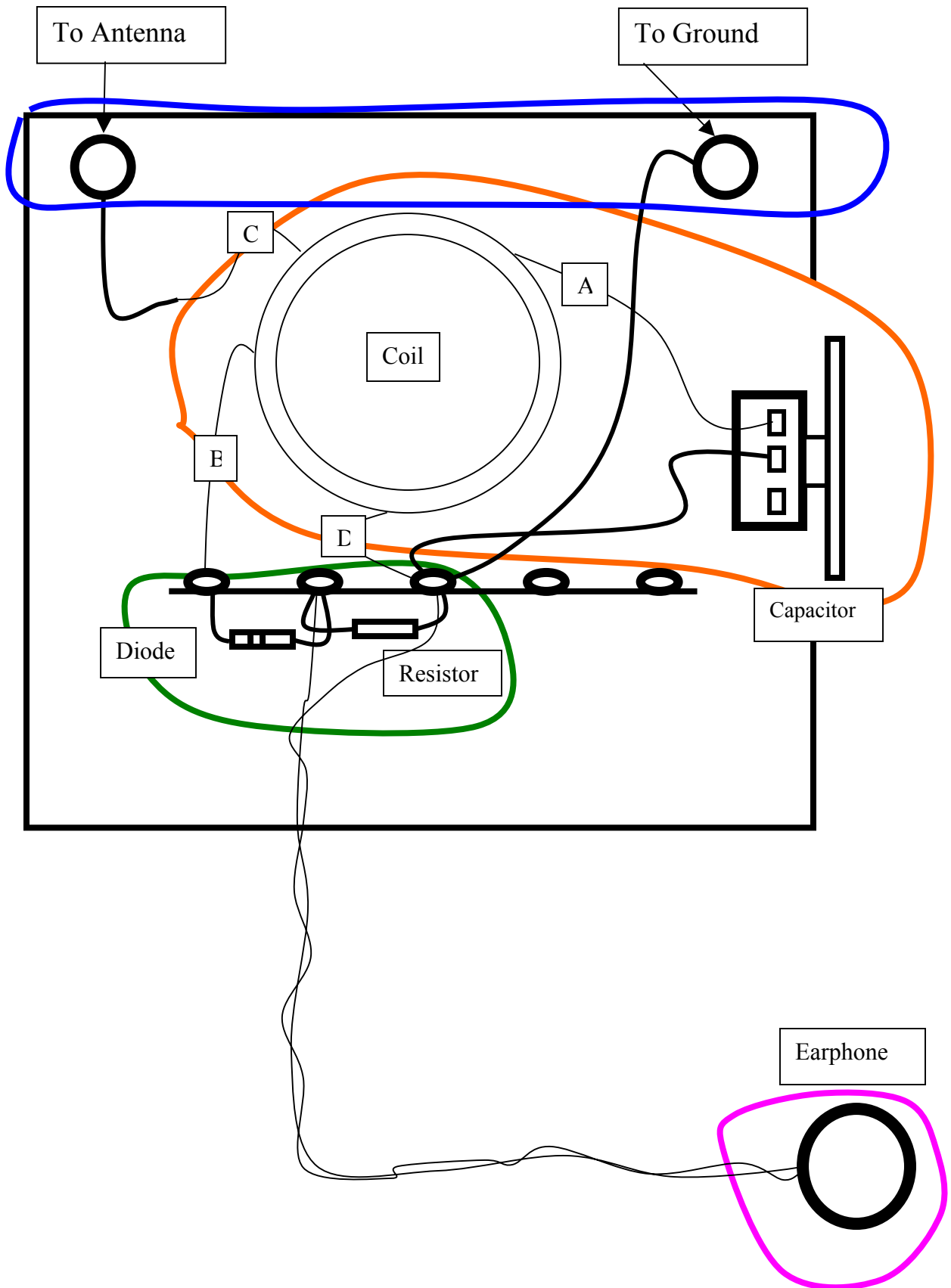

Using your radio:

Important Notes for Radio Builders and Parents

Antennas and Grounds and Warnings!!!

You'll need to connect your antenna and ground to the appropriate terminals through the clips on wires that you made up. Please be very careful not connect to live electric wires (conduit casing is fine for a ground however). Most importantly don't throw antenna wires over any utility cables: it is really really really dangerous if you get on an electric power wire. Also, don't ground to gas lines. Outdoor antennas are fine as long as they are temporary and are not left connected to your radio or house in times of possible lightning strikes. If you use a permanent outdoor antenna, you will need a lightning arrestor. A licensed electrician knows how to set one up, but that could be costly.

A swell ground is provided by a metal (not plastic, that won't conduct electricity!) cold water pipe. We have also had good luck with the metal nut on the outside of the cable connector for the local cable television service (be careful not to connect to the center conductor). You can make an antenna by stringing up your antenna wire as far as it will stretch. Outdoors it helps to get it off the ground, at least by a few feet. An antenna may also be provided by large pieces of metal such as a metal doorframe or rain gutter (again, think about the possibility of lightning and don't leave your set connected when not in use). One of the best antennas we have found is an air duct. For an outdoor birthday party, we found that a garden hose faucet made a swell ground. For the antenna, we found that a fine gauge magnet wire (like the #32 we use to wind our coils) sent up about 50' into a treetop by big Mylar helium balloon worked really well! The trick is to be patient and willing to experiment (for example try aiming the antenna in different directions). You should try to bite through paint with your clips to make contact with bare metal. It is possible however to connect by simply wrapping wire without making bare metal. Generally, avoid overlapping the antenna and ground wires. It will be fun to discover what works for you!

Tuning Your Radio:

Once you have set up an antenna and ground, just try turning the capacitor's knob. Good luck and have fun!

Trouble Shooting Defective Earphones

We have found that sometimes a good strong signal will fade away for no apparent reason while you are listening. If this happens to you, try rapping on the earphone (don't smash it so that it breaks! Striking with you finger with the force of a finger snap is the trick). We have found that doing this can quickly bring this back to life (you are likely to have to retune in case you moved the slug while trying to restore the signal). If this

happens to you, please let us know and we'll give you a replacement earphone in exchange for the defective one. We are pretesting our earphones, but you may still get a poor performer.

What to Listen for and When to Listen

You may be surprised to discover more stations at night than you can hear during the day. This is because the high reaches of the atmosphere can sometimes reflect radio waves from far way. If you're persistent, you may become an expert on this effect. Also, you may even pull in stations that are higher in frequency than the usual broadcast band.

More Information and Ideas for Home Experimentation

The World Wide Web is an amazing resource for more information on crystal radios and the crystal detector materials themselves. You can simply search under www.google.com for ``crystal radio.'' Here are some of the excellent sites you will find:

freeweb.pdq.net/headstrong/crystal.htm
www.midnightscience.com
<http://www.scitoys.com/scitoys/scitoys/radio/radio>
www.thebest.net/wuggy/build.htm

The wuggy website gives a great series of crystal radios under the link: The Project Crystal Radio. Our design is based on the second circuit.

The scitoys website of Simon Field is also not to be missed: his projects are exceptional in their fun, value and ease of building. As you will see, there are many marvelous variations and extensions to our current design. First, there are a great variety of antenna and ground possibilities. Within the radio itself, large tank coils can bring better performance both in signal strength and in ability to pick out one station at a time. You might wish to add a battery-powered one-transistor amplifier for portability (you will still need to have an antenna wire, but no ground is necessary). The regenerative receiver is an amazing few-transistor extension to provide extremely high sensitivity. With this design, you can readily detect waves with higher vibration rates (higher frequencies) that provide worldwide communication.

In order to modify your coil, you can pry it out of the glue that holds it to the base. You might prefer however to preserve your working radio and make a new one to try out a new design.

To learn more about the materials that make your radio work, you may enjoy books from a public library. Any edition of the ARRL's Handbook for Radio Amateurs will give you very useful information about what's inside your radio from the insulator inside your capacitor to the solder you used to make your set...

We look forward very much to news of your crystal radio experiences at home as well as any questions or stories to tell that you might have (grandparents know some of the most interesting radio tales). Our e-mail addresses are cpf1@cornell.edu and outreach@ccmr.cornell.edu.

Sincerely, Carl Franck, Juliane Bauer-Hutchinson, Nev Singhota, Kevin Dilley for the Cornell Center for Materials Research

Radio-Builder's Diagram (Schematic)

Here's another way to understand how the various parts of your radio connect to each other. Radio builders call this a schematic. Each part has a special symbol. Wires are simply lines. We'll bet you can quickly find your fancy coil. Radio builders understand how the signals flow through your radio a lot more easily by looking at this diagram than the physical layout on the early pages. If you get a new idea to try out, you can explain to another radio builder easily by just drawing the new schematic. You might like to get some practice reading schematics by figuring out where our four sections of the radio are on this schematic. Good luck!

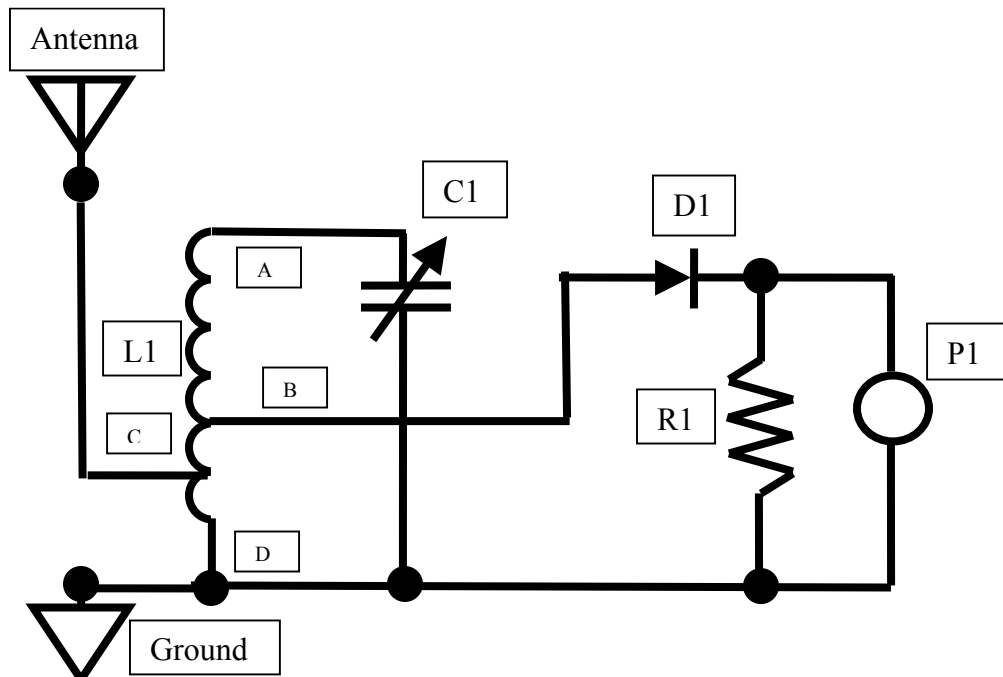

Antenna wire is 15' long medium sized clip on the end
Ground wire is 10' long with large clip on end

L1: Coil is 140 non-overlapping turns of #28 wire on 1.5" (inner diameter) thick walled PVC pipe (3" long) tapped at 20 and 40 turns from the ground side.

C1: 141(max) pf variable capacitor

D1: 1N34A diode

R1: 10K resistor

P1: piezoelectric earphone

Coil Winding Instructions

To wind the coil, tack the wire down with hot glue initially, wind five turns at a time side by side, taking up slack afterwards while compressing the coil after every set of five turns.

Starting from the bottom (wire connection D), wind 20 turns, bring out tap C, wind another 20 turns, bring out tap B, complete with 100 turns to end with connection A.

This version of the Make-A-Radio notes was made 7/28/03. C.F.