

DIY KIT 9. OSCILLATOR BUILDING BLOCKS

Oscillators are everywhere in electronics. They are a basic building block upon which the whole structure of electronics and computers is based. This kit looks at the 3 basic types of multivibrators (MV). They are designed to have zero, one or two stable states; the astable (the prefix 'a' means 'not') or free running MV, the monostable MV (also called the one-shot) and the flip-flop or bistable ('bi' means 2, bistable means 2 stable states.) In the flip-flop MV a trigger pulse or control signal is required to change from one state to the other. MV's use regenerative (positive) feedback; the active components present within the circuit operate as switches being alternately cutoff or driven into saturation. These circuits have now largely been replaced by timer ICs like the 555. (See Kit 111.) However, a basic understanding of them is still essential since they are still used in many circuits.

This kit builds each of these three circuits and allows you to experiment with them. To understand how these circuits work will also make sure you have an understanding of resistors, capacitors, RC characteristics, the transistor as a switch and the light emitting diode (LED).

ASSEMBLY INSTRUCTIONS

It is usually easier to add the smallest height components, the resistors, first. All the small-signal transistors are the same. Solder a 1/2" (10mm) length of wire which has been cut from the leads of the other components into the three holes marked Trigger, Set and Reset. Add two flying leads of wire about 3" long to the positive rail and to the negative rail using any spare insulated wire you have in your junk box. You will use these flying leads to touch the trigger, set and reset points to see what effect they have on the operation of two of the MV's.

CIRCUIT DESCRIPTION

Most basic electronic text books give a review of these three MV's. We suggest you use a text book as well as our explanations below in order to get a good understanding of these basic topics. The transistor BC547 is used in all three circuits. You can download the data sheet from

<http://kitsrus.com/pdf/bc547.pdf>

A diode on the input protects the kit if the battery is connected wrongly. When the 9V battery is connected, the astable MV should flash from one LED to the other. One LED should be on for about twice the time of the other. The LED in the monostable MV should remain off. In the RS flip flop one LED should turn on and stay on. Two flying leads are provided, one on the 9V rail and the other on the earth rail. Play with touching the flying wires to the trigger, set & reset points. Try to follow what happens on the circuit diagram when you touch a lead. What you see is all to do with transistors acting as switches and capacitors charging and discharging with a time constant determined by an R and a C in the charge path. You cannot do any harm to the components by playing with the flying wires since each has a 1K resistor in it to limit the base current through the transistor so that it cannot be damaged. If you have access to a CRO look at the changes of the

base/emitter voltages of the transistors as you touch trigger, set & reset.

1. The Flip Flop/Bi-stable.

Computer memory elements (the group of circuit components in a memory IC which stores each 'bit' - binary digit) use the flip-flop principal. Play with the flying wires onto the set and reset wires. You can very quickly see what this circuit does; it remembers information about which was the last LED to be made to be turned on or off. Of course, you have to define a convention: which flying wire you are using, which pin is called what. Eg, set, reset, Q, /Q.

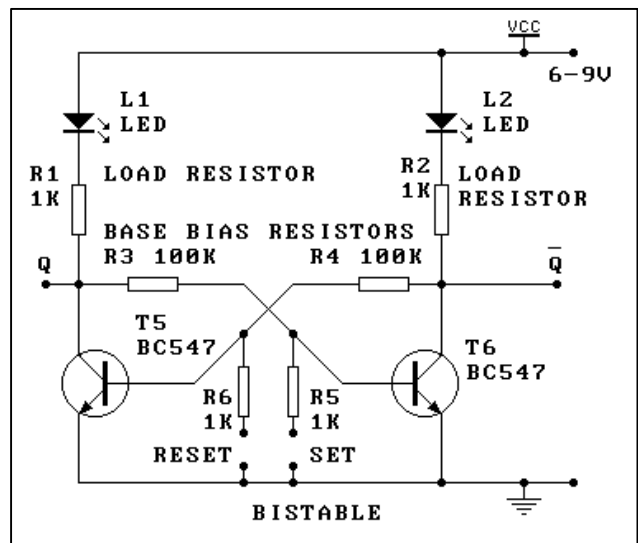

When the power is connected to the circuit one or other of the two transistors will turn on. Both transistors will try to turn on as the base of each tries to go high. But due to slight differences in component values one will be quicker than the other. Suppose it is T5. This means that T5 collector voltage is low (below .65V), which means that the base of T6 is also low (since the two are connected) and T6 is off. Now when the set lead is touched by the positive rail, T6 is turned on because its base potential is raised over 0.6V. So T6 turns on and its collector potential drops which drops the base potential of T5 to below 0.65V and so T5 turns off. The circuit has flipped into its other state. Touch the reset with the positive lead and the circuit flops back to T5 turned on again.

We called one LED the set, and the other reset but these names are arbitrary. The flying negative lead also causes the LED's to turn on/off but in the opposite way to the sequence caused by the positive flying lead. Study what is happening with the schematic above as you touch the set and reset..

2. The Monostable Multivibrator.

Now we introduce an RC network into the flip flop circuit just described. An electrolytic capacitor replaces one of the base bias resistors of the flip flop circuit. And the biasing which was supplied by this resistor is provided by a 56K

DIY KIT 9. OSCILLATOR BUILDING BLOCKS

resistor to the positive rail. When the power is turned on the circuit will settle into a stable state in which T4 is on and T3 is off. Use a multimeter to measure the base/emitter and collector/emitter voltages of T3 & T4 to show this. The capacitor will have about 6V across it. It is the

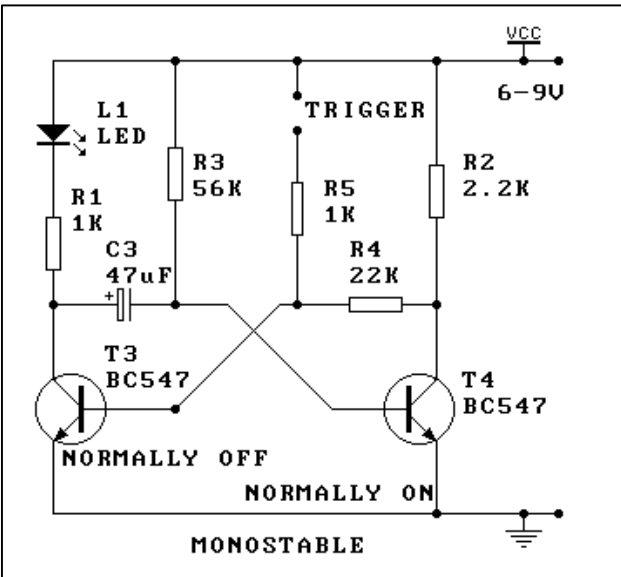

capacitor in the circuit which determines that T3 will be off, and T4 will be on in its stable state.

A high applied to the trigger point turns T3 on. Then after a few seconds T3 turns off and returns to the stable state. What has happened is that as soon as the trigger goes high, T3 is turned on and the positive end of the capacitor is taken to zero. This immediately drags the negative end of the capacitor to below zero potential. This turns T4 off since the negative of the capacitor is connected to the base of T4. The LED turns on because T3 is on. But then after the pulse is removed C3 starts to charge up with a time constant determined by C3 and R3. Then when the voltage on the negative end of C3 reaches 0.65V, T4 starts to turn on, T3 turns off and so does the LED. The state is then stable again.

Play with this over & over until you understand what is happening. A low pulse delivered to the trigger point when the LED is off does nothing because it is already almost at the same ground potential.

3. The Astable or Free Running MV

In this MV we replace the second base bias resistor by an RC network. You can think of it as two monostable MV's connected together; the output of one feeds the input of the other. First one LED is turned on, then the other. The output is a square wave. Its mark/space ratio and its frequency is determined by the values of the R & C components. The time that the collector of T2 is low (& T1 high) is determined by the time constant R2 & C2. Similarly, the time the collector of T1 is low (& T2 high) is determined by the time constant of R1 & C1. We made R1 about twice the value of R2 to highlight this. The time constant is: $t=0.693 RC$. Work them out for yourself to check what you observe.

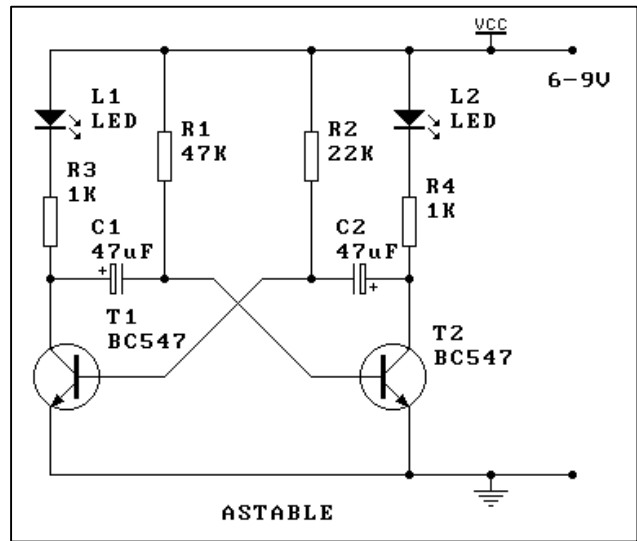

WHAT TO DO IF IT DOES NOT WORK

Poor soldering is the most likely reason that the circuit does not work. Check all solder joints carefully under a good light. Next check that all components are in their correct position on the PCB. Is the battery OK? Are the LEDs in the correct way?

WHAT TO LEARN FROM THIS KIT

It is quite amazing when you think about it - you apply a constant voltage to a simple circuit consisting of 2 transistors, 2 capacitors and 4 resistors and what is produced is an oscillation. Just alter the component values of the astable MV and you have a square wave generator for whatever frequency and mark/space ratio you wish. Try changing some of the resistor and capacitor values. Try to work out the RC values and correlate to the times the LED's stay illuminated.

COMPONENTS

Resistors 5%, 1/4W:	
1K brown black red	8
2K2 red red red	1
22K red red orange	2
100K brown black yellow	2
56K green blue orange	1
47K yellow violet orange	1
47uF electrolytic capacitor	3
BC547B small signal transistor	6
5mm bright red LED	5
1N4004	1
Kit 9 printed circuit board	1
9V battery snap	1

See our website at <http://www.kitsrus.com>