

APPLICATION NOTE

APPLICATIONS OF MAGNETIC POSITION SENSORS

ABSTRACT

Magnetic position sensing using Anisotropic Magneto-Resistive (AMR) sensors is becoming a popular method of implementing a non-contacting location of motional objects. By affixing a magnet or sensor element to a angular or linear moving object with its complementary sensor or magnet stationary, the relative direction of the resulting magnetic field can be quantified electronically. By utilizing multiple sensors or magnets, the capability of extended angular or linear position measurements can be enhanced. This application note explains the principles of AMR sensors for positional measurements, and includes several real-life circuit applications to solve engineering problems.

PRINCIPLES OF AMR SENSORS

Anisotropic Magnetoresistance occurs in certain ferrous materials and can be applied as a thin strip to become a resistive element. Honeywell uses a ferrous material called Permalloy and forms four resistive elements to become a wheatstone bridge sensor. Each magneto-resistive strip element possesses an ability to change resistance in a $\cos^2\theta$ relationship where θ (theta) is the angle between the magnetic moment (M) vector and the current flow (I). Figure 1 shows the Permalloy element with field and current applied.

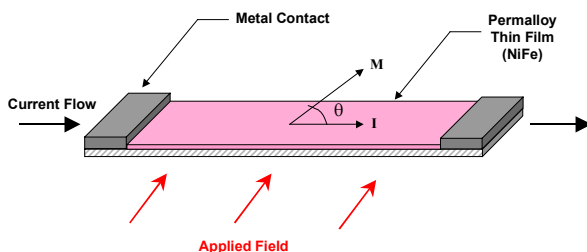

Figure 1
AMR Element

To create the sensor from the AMR elements, the four elements are oriented in a diamond shape with the ends connected together by metalization to form the wheatstone bridge. Arbitrarily, the top and bottom connections of the four identical elements are given a Direct Current (DC) stimulus in the form of a supply voltage (V_s), with the remaining side connections to be measured. With no magnetic field supplied (0 gauss), the side contacts should be at the same voltage,

except for a small offset voltage due to manufacturing tolerances on the AMR elements. With the AMR elements connected in this fashion to form the wheatstone bridge, these side contacts will produce a differential voltage (ΔV) as a function of the supply voltage, MR ratio, and the angle theta (θ); which is the angle between the element current flow and element magnetization (M). Figure 2 depicts this sensor bridge.

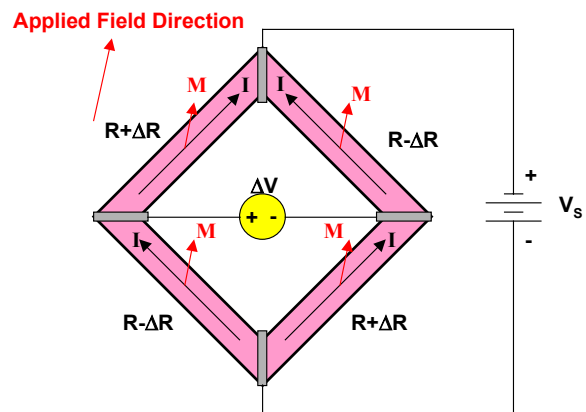

Figure 2
AMR Bridge

To have the element magnetization direction to align with an externally applied magnetic field, the applied field must “saturate” the permalloy material. As opposed to other AMR sensor elements that operate in a linear mode, position sensing is a saturation mode function; meaning that the external magnetic field completely re-oriens the material’s magnetization. For Honeywell’s magnetic position sensors, a minimum of an 80 gauss magnetic field must be applied at the bridge for the specified performance characteristics to be met. Fields less than 80 gauss will show some bridge operation, but the saturation may not be complete enough to be relied upon.

OUTPUT SIGNALS

The HMC1501 and HMC1512 are Honeywell’s AMR based magnetic position sensors that contain AMR sensor bridges to be used in saturation mode. The HMC1501 contains one AMR bridge for a $\pm 45^\circ$ range of position sensing, and the HMC1512 contains two AMR bridges for a $\pm 90^\circ$ range of position sensing. The bridge differential output voltage (ΔV) for the HMC1501 is:

$\Delta V = -V_s S \sin(2\theta)$ where:

- V_s = Supply Voltage (volts)
- S = Material Constant (12mV/V)
- θ = Reference to Magnetic Field Angle (degrees)

With the bridges on the HMC1512 oriented 45° in rotation from each other, the differential output voltage for sensor bridge A is:

$$\Delta V_A = V_s S \sin(2\theta)$$

And for sensor bridge B, the differential output voltage is:

$$\Delta V_B = -V_s S \cos(2\theta)$$

Using the HMC1512 bridge A signal output plotted versus theta, figure 3 depicts the two-cycle waveform.

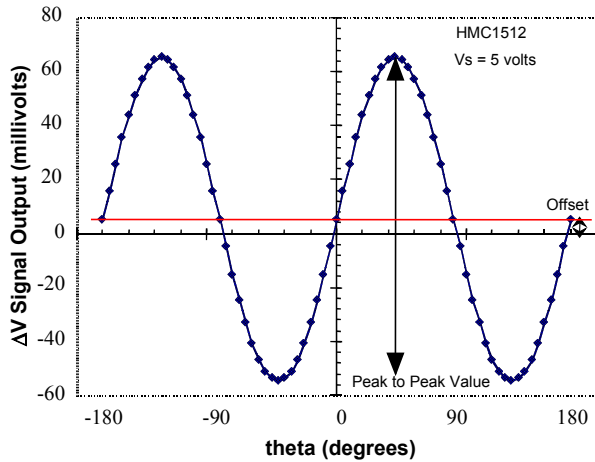

Figure 3
Two Cycle Waveform

As you can see above, the most linear range for this sensor bridge is in the $\pm 45^\circ$ range about the $-180, -90, 0, 90,$ and 180 degree points. Of these the 0 and ± 180 points have a positive slope, and the ± 90 points have a negative slope. These slopes can be taken to full advantage for angular and linear positioning applications.

Now that we have a fairly accurate method for magnetic field direction sensing established, it should be noted that some errors should be adjusted to enhance the accuracies of the measurements. The first one is the offset error voltage as depicted in figure 3 and mentioned earlier as a byproduct of manufacturing tolerances. To compensate for the offset, either analog signal processing or digital value corrections can be used. In the analog signal processing solution, an opposing error voltage can be summed into the bridge

output signal via signal conditioning circuitry. In the digital solution, the digitized value of the output signal can be combined with an error correction value.

Another common error to be accounted for is the drift in the material constant versus temperature. This error affects both the bridge sensitivity and offset. Coefficients of temperature (tempcos) of the sensitivity and offset are nominally $-0.32\%/^\circ\text{C}$ and $-0.01\%/^\circ\text{C}$ respectively. If your application should have a large operating temperature range, consider some temperature monitoring circuitry to produce error corrections to offset the temperature drift.

If you use multiple bridge sensors, another error that should be compensated for is the part-to-part tolerance in material constant. This manifests itself as a change in sensitivity, resulting in varying peak-to-peak voltage swings in the ΔV versus theta plots. Much like the offset error voltage, analog signal processing or digitized value corrections can be implemented to counter this sensitivity tolerance.

POSITION SENSING

For simple magnetic position sensing, the HMC1501 sensor can be used to detect the relative motion of a nearby magnet in linear or angular displacement. Figure 4 shows a typical orientation.

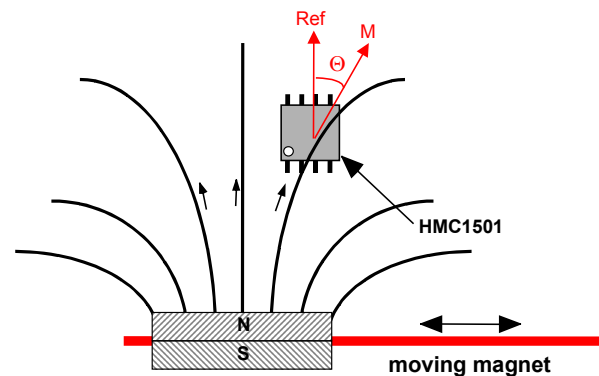

Figure 4
Position Sensing

With the orientation of the stationary HMC1501, the magnet can translate to $\pm 45^\circ$ and stay within a linear slope of ΔV versus θ for position sensing. Given a typical supply voltage of 5 volts ($V_s = +5\text{Vdc}$), the HMC1501 will provide about a 120 millivolt swing (± 60 millivolts) on 2.5 volt bias voltage. The reason for the 2.5 volts is that with the wheatstone bridge supply voltages at 0 and +5 volts, the bridge performs a rail splitter function to create two near +2.5 volt sources driven apart by ΔV as created by the magnetic field and the offset error voltage. Figure 5 shows this transfer curve.

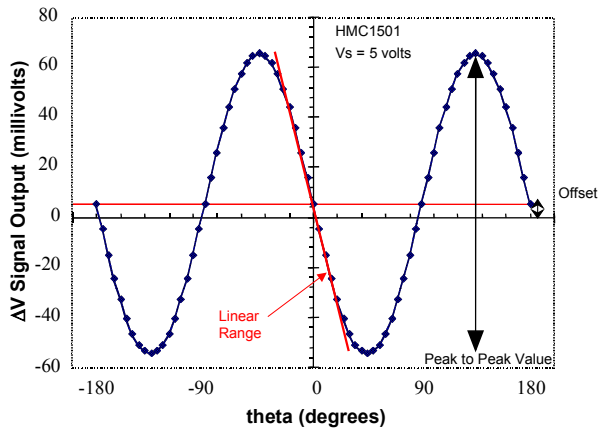

Figure 5
Transfer Curve

To interface with output pins of the HMC1501 (OUT+, OUT-), an instrumentation amplifier circuit is typically used. Instrumentation amplifiers can be purchased as complete integrated circuits, or constructed via combinations of discrete components and integrated circuits; such as operational amplifiers (op-amps). The purpose of an instrumentation amplifier is to derive the difference signal (OUT+ minus OUT-), and to provide additional signal amplification as desired. Figure 6 shows a typical instrumentation amplifier circuit using an op-amp with external discrete components.

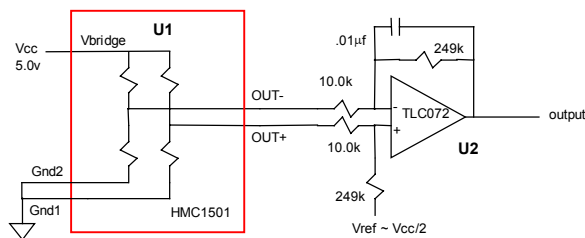

Figure 6
Instrumentation Amplifier

With a nominal 120 milli-volts peak-to-peak signal swing at the bridge outputs, the above circuit schematic shows an instrumentation amplifier with a voltage gain of about 25. This will permit an output voltage swing of about 3 volts peak-to-peak centered up on about 2.5 volts (1 to 4 volts). Since the bridge offset specification is $\pm 7\text{mV/V}$, a 5 volt supply applied to the bridge yields $\pm 35\text{mV}$. After the instrumentation amplifier gain, this offset is $\pm 850\text{mV}$ which will stay within the power supply rails when combined with the amplified signal.

One method of countering the offset error voltage at the bridge is to change the value of V_{ref} at the instrumentation amplifier from 2.5 volts to a nearby

voltage so that the amplifier output voltage remains at 2.5 volts at each 90° rotation in field direction. This can be done using a trimming potentiometer (trimmer pot) with the wiper to V_{ref} and the end positions of the potentiometer towards each supply rail. Figure 7 shows this method.

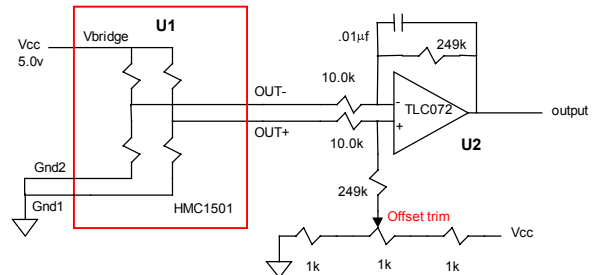

Figure 7
Offset Trimming

Another method of offset error voltage compensation is to just measure it at production test and subtract that value from all future measurements. The advantages of this method is that the circuit component count remains minimal (like figure 6), and no trimming procedure is required. The disadvantage is that you may have to reduce the amplifier gain to accommodate all the error buildup in offset and sensitivity tolerances, plus tempco changes that are all multiplied by the amplifier gain.

WIDER POSITION SENSING

To go from $\pm 45^\circ$ to $\pm 90^\circ$ requires two HMC1501 sensors or a single HMC1512 dual sensor part. By using two bridges with 45° displacement from each other, the two linear slopes can be used additively. Figure 8 shows a typical configuration.

From Figure 8, as the shaft rotates around, magnetic flux from a magnet placed at the end of the shaft exits the north pole and returns to the south pole. With a HMC1512 placed on the shaft axis, just above the magnet, the flux passing through the sensor bridges will retain the orientation of the magnet. From this rotation, the output of the two bridges will create sine and cosine waveforms as shown in Figure 9.

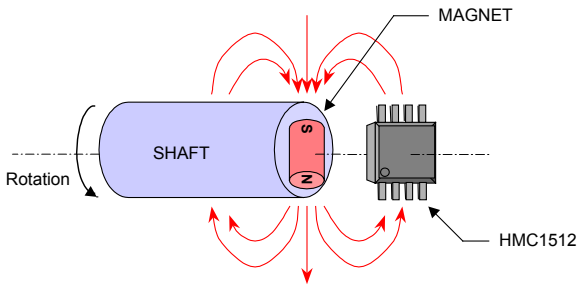

Figure 8
Wide Position Sensing

Because most trigonometric functions are performed as memory maps in microcontroller integrated circuits, these kinds of special case conditions are easily dealt with. The resultant angle θ is the relative position of the magnetic field with respect to the sensor. It should be noted that if rotation is permitted beyond $\pm 90^\circ$, the θ calculation will replicate again with positive and negative 90° readings jumping at the end points. Further performance to 360° or $\pm 180^\circ$ can be mapped into a microcontroller by using this circuit plus a Hall Effect sensor to determine which side of the shaft is being positionally measured via magnetic polarity detection. Figure 10 shows the basic circuit interface for the HMC1512.

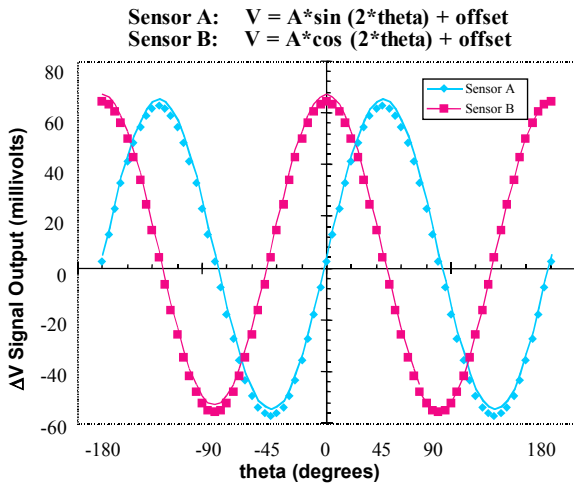

Figure 9
Sine, Cosine Waveforms

Because the sine (sensor bridge A) and cosine (sensor bridge B) will match after the offset error voltages are subtracted, the ratio of bridge A to bridge B creates a tangent 2θ function and the amplitude A values cancel. Thus the angle θ is described as:

$$\theta = 0.5 \cdot \arctan(\Delta V_a / \Delta V_b)$$

However because there are some trigonometric nuances with the arctangent function when θ gets close to $\pm 45^\circ$ and beyond, these special cases apply:

For $\Delta V_a = 0$, $\theta = 0^\circ$

For $\Delta V_b = 0$ and $\Delta V_a < 0$, $\theta = -45^\circ$

For $\Delta V_b = 0$ and $\Delta V_a > 0$, $\theta = +45^\circ$

For $\Delta V_a < 0$ and $\Delta V_b < 0$, subtract 90° from θ

For $\Delta V_a > 0$ and $\Delta V_b < 0$, add 90° from θ

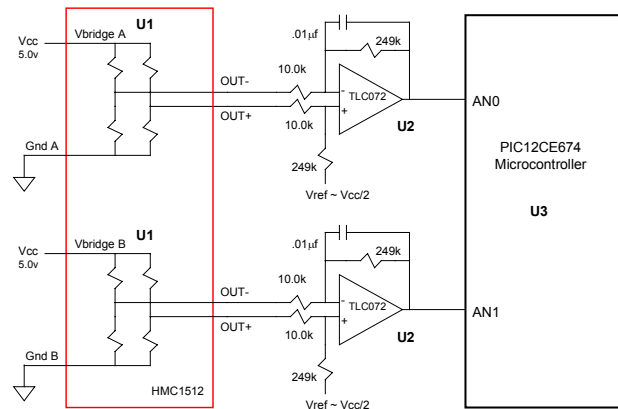

Figure 10
HMC1512 Circuit

LINEAR DISPLACEMENT SENSING

For extended length linear position sensing, multiple sensor bridges can be lined up next to a traveling magnet sliding past the bridges. For best resolution and linearity, the $\pm 45^\circ$ range should be backed down a bit to around $\pm 30^\circ$. As part calculating how many linearly arrayed bridges are needed for fixed amount travel (displacement), the magnet to bridge standoff distance should be determined. For common magnets like ceramic and AlNiCo types with under a kilo-gauss of magnetic field strength at the pole face, a maximum of about 0.25 inches of standoff distance will be reasonable; so that the nearest two to three bridges will be in saturation (>80 gauss) from the magnet. For rare earth magnets, such as Neo-dymium types, with pole face fields around 3 kilo-gauss or more; a standoff distance of 0.5" can be achieved. Figure 11 shows a typical array of four HMC1501 single bridge sensors with nominal magnet displacement ranges.

From Figure 11, a single bridge sensor produces a ΔV versus position in a linear position arrangement. This will create a waveform much like figures 3 and 5 except that the end points of displacement fall away

from the sinusoidal pattern if the magnetic field will continue to maintain saturation levels at the bridges. If the levels fall away from saturation quickly, distant bridge ΔV 's may still be left near the peaks of the sinusoidal pattern until the magnet travel returns to re-saturate the bridges. Figure 12 depicts this linear displacement waveform for a single sensor.

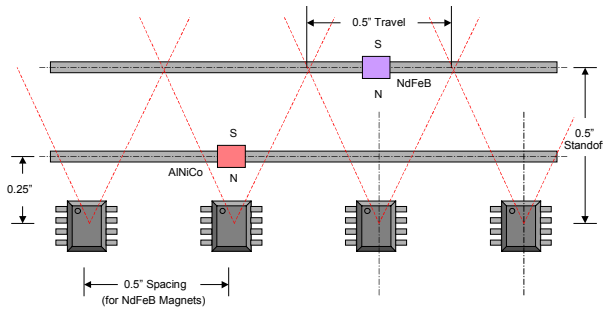

Figure 11
HMC1501 Array

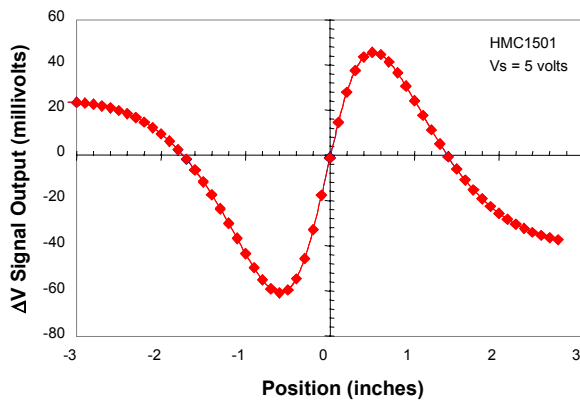

Figure 12
Linear Displacement Waveform

The above figures show a design for about a 2 inch displacement sensor system. Typical resolution of position is around 2 mils (0.002") with an accuracy of 0.1% largely dependant on the supporting interface electronics.

In interpreting the ΔV signals from each sensor bridge, each bridge is calibrated by cancelling out the offset error voltage, and by measuring the peak-to-peak bridge waveform and creating a scaling factor for each bridge's output so that the final adjusted peak-to-peak range is the same. Once calibrated, each sensor voltage value is collected and a comparison routine is started. The routine takes the calibration corrected values and creates a "slope" value in-between adjacent sensors. From figure 12, note that the bridges with the magnet closest to them will demonstrate a positive slope on one or both sides of the measured ΔV . The routine then locates the smallest ΔV with one

or more positive slope values; and that will be the linear range value to be used. Figure 13 depicts the combined bridge waveforms plotted with the magnet approximately centered up on the second bridge sensor.

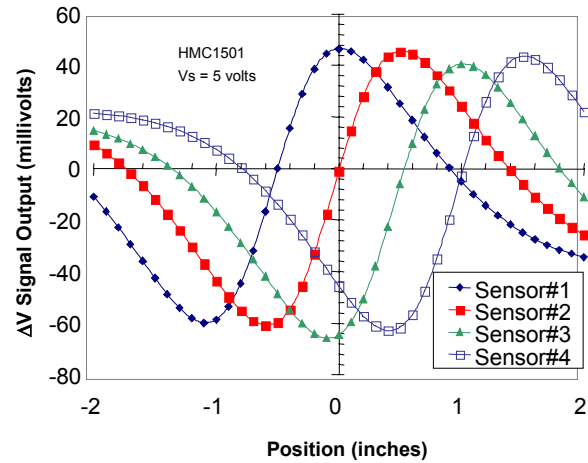

Figure 13
Combined Bridge Waveforms

Once the routine has ascertained the correct bridge and its analog value, a final value can be chosen to relate the position to a number. For example, if each bridge is connected to an 8-bit Analog-to-Digital Converter (8-bit ADC), then 256 possible values (1 to 256 points) can represent a magnet position in its displacement range. With an array of four sensors, a number from one to 1024 points can represent the entire travel range. If sensor #2 is chosen with the value of 132 points, then a point value of 388 would represent the relative position (256 points for sensor #1 plus 132 points for sensor #2) of the magnet.

Two notes on the above description you should be aware of. One is that the slopes can be inverted if the sensors are rotated $\pm 90^\circ$ so that you would look for negative slopes instead of positive slopes. The second is that ADC resolution increases can bring much more precision if needed. The above example is 8-bit, but 10, 12, and 16 bit ADC devices can be used. Figure 14 shows a typical circuit for the above example design.

MOTOR SHAFT POSITION SENSING

Not all motors have the convenience of having the end of a shaft available for magnet placement. For those applications where the magnets must be placed along the circumference of the shaft, several approaches are available. The "wider position sensing" section covers the sensor at the end of the shaft, but two HMC1512 could be positioned 180° on each side of the shaft with a split magnet located above or below the sensors to come close to the end position sensing. However,

there are new magnet designs available from various manufacturers that can create ring shaped magnets that can create north or south pole magnetized pie sections for shaft position sensing.

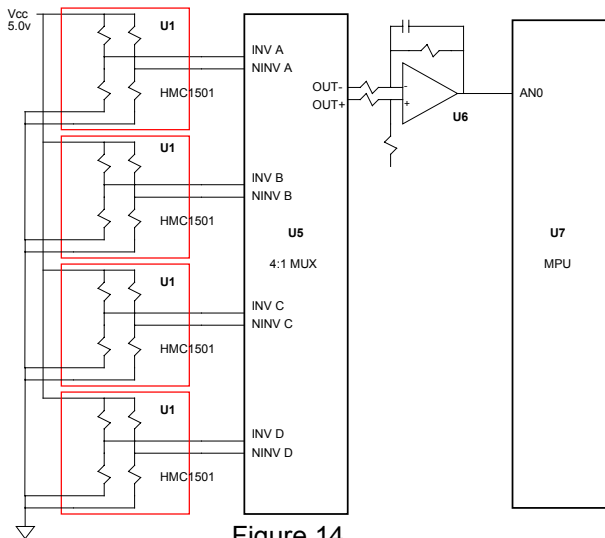

Figure 14
Array Circuit

With sectioned ring magnets, at least two ways could be envisioned to locate motor shaft position. The first is to locate one or two narrow pie section pole faces and wrap an array of HMC1501 sensors; much like the previous linear position sensor section described. Then each sensor gets a portion of shaft rotation to operate on. The second way is to conserve on sensors and use a multi-section ring magnet to provide a repeating pattern of north and south magnet poles. For example, a ring magnet of 6 to 8 sections and two HMC1501 sensors could offer precise shaft position.

To keep accuracy high the ring magnet needs to keep the pole faces in smaller increments than when using Hall Effect sensors in a linear (amplitude) mode of operation. Also some forced spacing between north and south poles is required to ensure that no gaps in saturating magnetic fields are small. Figure 15 shows a typical ring magnet design of shaft position sensing.

As you can see, the two HMC1501 sensors do not cover the whole rotation of the shaft, but concentrate on one location. This is to best group the sensor assembly for practical packaging reasons and to consider the need of magnetic shielding from motor field coils in close proximity. Another item to note is that there is pattern overlap in the placement of the two sensors so that one or the other will be in saturation and that the one sensor who's ΔV is closest to zero will be the best measurement.

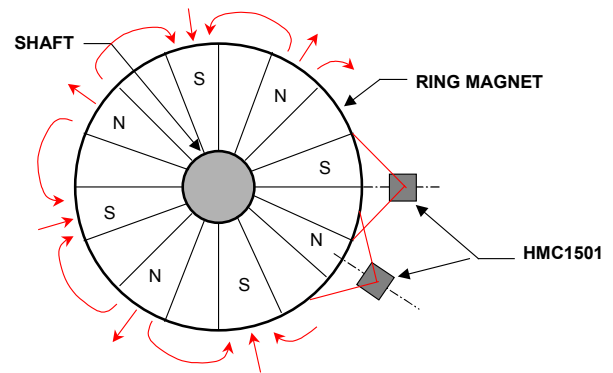

Figure 15
Ring Magnet Design

360 DEGREE ROTATION SENSING

To create a full 360° rotational position sensing solution, the HMC1512 sensor can be combined with a hall effect sensor. Most hall effect sensors use silicon semiconducting materials to create a proportional voltage output as a magnetic field vector slices orthogonally through the slab material with a bias current flowing through it. Figure 16 shows this principal.

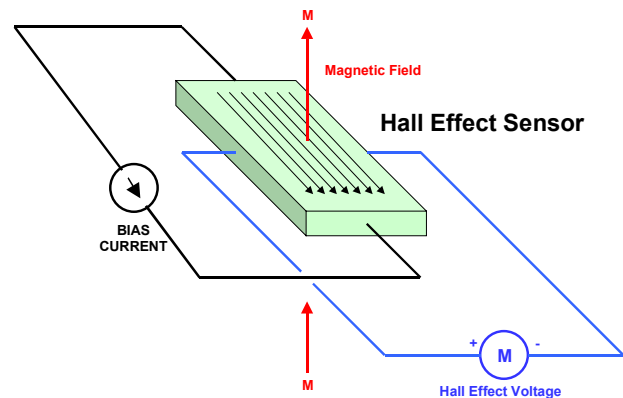

Figure 16
Hall Effect

Although hall effect sensors do not offer the sensitivity or precision for accurate position sensing, they are used for 360° position sensing as “polarity” detectors to determine which half of the HMC1512’s rotation a magnet is in. Figures 17 and 18 show a typical orientation and resulting waveforms for 360° position sensing.

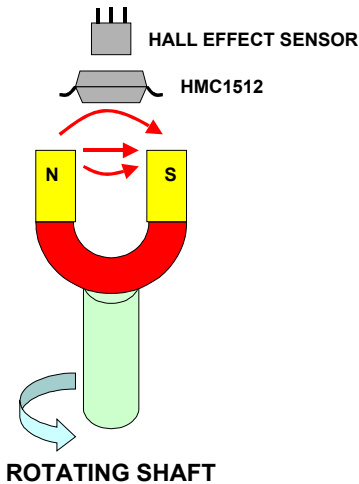

Figure 17
360° Position Sensing

As the magnetic flux rotates about the HMC1512 and the hall effect sensor, the hall effect sensor's voltage will reverse its polarity at the flux vector changes from back-to-front to front-to-back through the silicon slab.

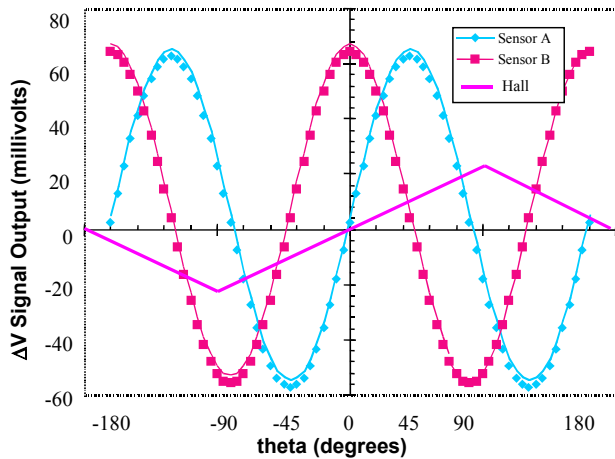

Figure 18
360° Sensing Waveform

By placing a comparator on the hall effect sensor analog output, a digital representation of half rotation polarity is achieved. When combined with $\pm 90^\circ$ sensing circuits of the HMC1512, the sensing range is doubled providing a complete $\pm 180^\circ$ or 360° rotational sensor of high accuracy. One note is to mechanically ensure that the hall sensor is nearly perfectly orientated with respect to the HMC1512, so that the arctangent equation deriving the heading arrives at the end positions just as the hall sensor output achieves a zero volt output.

MINIMALIST POSITION SENSING

To make one sensor handle larger linear or angular ranges than specified, is to be creative with magnet designs to force in-specification field directions during a complete linear translation or a whole one-turn rotation of the shaft. For the linear application, Figure 19 shows a typical method.

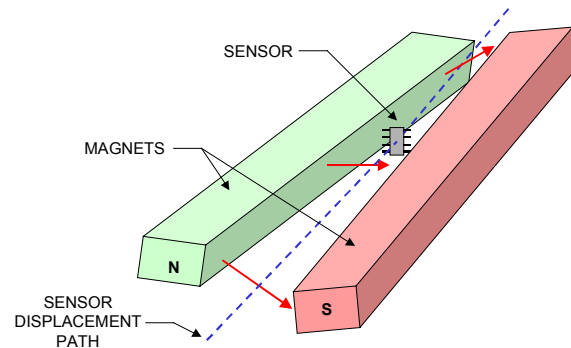

Figure 19
Tilting Magnets Method

The above figure shows two magnets tilted slightly from each other while maintaining a consistent gap in spacing in which a sensor will travel between the magnets. In the near position, a downward angled flux path is produced, with a horizontal direction at mid-travel, and an upward angle at the far position. Thus a single bridge's linear sensing range is spread out through a fairly long displacement length. Either the magnets or the sensor itself can be made to move relative to the other.

For angular position, Figure 20 shows two ring magnets on a rotating shaft. Each ring magnet is eccentric to the shaft and magnetized parallel to the shaft. Each magnet is 180 degree eccentric from each other and has a gap for the sensor to reside into. Two position sensors are placed 90 degrees apart to perform a total 360 degree position sensing arrangement.

Another key specification is the bandwidth of the sensor bridge. While the HMC1501 and HMC1512 promise up to 5 Mega-Hertz of bandwidth, careful attention to magnetic and electronic design practices must be paid when position sensing at high shaft speeds. Particular emphasis should be made to keep bridge to signal conditioning layouts tight to minimize stray capacitance that may eat up precious system bandwidth. This becomes very critical when using multipole magnets in angular rotation.

THE HUMAN RESPONSE

When working with position sensing that interacts to human manual inputs, note that there is a minimum latency that can be tolerated when eye-hand coordination is desired. This typically is perceived as 20 position updates per second, or about 50 milliseconds per update. So when allocating time for analog-to-digital conversion, ensure extra budgeted time for computation and display settling times. This is especially true when using Liquid Crystal Displays in cooler environments.

THE AMR VALUE PROPOSITION

The use of Anisotropic Magneto-Resistive sensors provides a contactless method of achieving angular or linear position sensing. Unlike Hall Effect Devices that require kilo-gauss level magnetic fields from rare earth magnets, the HMC1501 and HMC1512 provide a higher resolution sensor with much less field strength. The dominant limiting factor on resolution is typically the analog to digital converter bit size over the boltzman noise of the resistive elements..

Linear sensing ranges of the HMC1501 and HMC1512 can be easily extended by using multiple sensors and component counts can be minimized by multiplexing sensor output signals to one or more analog to digital converter ICs. Multiplexing can also be utilized to reduce sensor power consumption in energy limited applications.

Both sensor types are available in small SOIC-8 packages or in raw die form by special request. These plastic encapsulated silicon sensor die are inherently insensitive to mechanical shock and vibration.

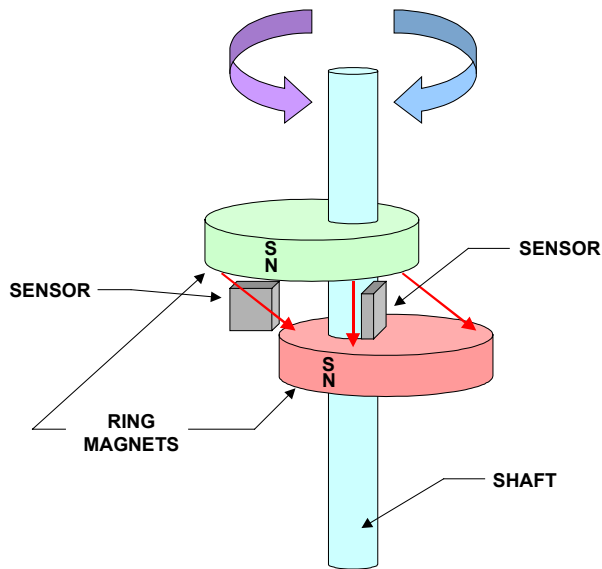

Figure 20
Eccentric Ring Magnets

One note to mention is that only the outer area of the eccentrics are magnetized so that the flux direction will create a “cage” of lines that bend inward or outward depending on shaft position.

KEY SENSOR SPECIFICATIONS

In choosing appropriate interface circuitry to sensor bridges, certain key specifications should be emphasized. The first specification to be noted is the bridge resistance. Since the HMC1501 and HMC1512 have different bridge resistances (5000 and 2100 ohms respectively), the user may favor over the other based on power consumption or noise performance. If power consumption is of primary importance, the user has the option of gating or “duty cycling” the sensor bridge power supply to lower the total energy demand. If low noise performance is the utmost criteria, then lower bridge resistance favors lower noise voltages.

Bridge sensitivity is another key specification that should be examined by users. Both the HMC1501 and HMC1512 exhibit a 1.8 to 2.1 millivolts per degree sensitivity in their most linear regions of performance. Given a nominal ± 120 millivolt output voltage and sub micro-volt noise floors, allows for better than tenths of a degree angular resolution. By choosing the right signal conditioning bandwidth and the amount of effective bits of analog-to-digital converter resolution, the user can play into the strengths of these AMR sensors.