

Johnson Noise and Shot Noise: The Determination of the Boltzmann Constant, Absolute Zero Temperature and the Charge of the Electron

MIT Department of Physics
(Dated: November 30, 2010)

In electronic measurements, one observes “signals,” which must be distinctly above the “noise.” Noise induced from outside sources may be reduced by shielding and proper “grounding.” Less noise means greater sensitivity with signal/noise as the figure of merit. However, there exist fundamental sources of noise which no clever circuit can avoid. The intrinsic noise is a result of the thermal jitter of the charge carriers and the quantization of charge. The purpose of this experiment is to measure these two limiting electrical noises. From the measurements, values of the Boltzmann constant, k , and the charge of the electron, e , will be derived.

1. PREPARATORY QUESTIONS

1. Define the following terms: Johnson noise, shot noise, RMS voltage, thermal equilibrium, temperature, Kelvin and centigrade temperature scales, entropy, dB.
2. What is the physical basis of the Nyquist theory [1] of Johnson noise? Give an estimate for the RMS voltage across a $50\text{k}\Omega$ resistor at 100°C with a frequency range of 100 to 10,000Hz.
3. What is the mean square of the fluctuating component of the current in a photodiode when its average current is I_{av} ?
4. Your measurement of the noise at a frequency $f \pm \delta f$ is inaccurate at the following level: $N = N_f \pm 2N_f$. How many additional measurements are needed to get a result accurate to 5%.

The goals of the present experiment are:

1. To measure the properties of Johnson noise in a variety of conductors and over a substantial range of temperature and to compare the results with the Nyquist theory.
2. To establish the relation between the Kelvin and centigrade temperature scales.
3. To determine from the data, values for the Boltzmann constant, k , and the centigrade temperature of absolute zero.

2. INTRODUCTION

2.1. Microscopic Quantization

“Thermal physics connects the world of everyday objects, of astronomical objects, and of chemical and biological processes with the world of molecular, atomic, and electronic systems. It unites the two parts of our world, the microscopic and the macroscopic.”[2]

By the end of the 19th century, the accumulated evidence from chemistry, crystallography, and the kinetic theory of gases left little doubt about the validity of the atomic theory of matter, though a few reputable scientists still argued strongly against it on the grounds that there was no “direct” evidence of the reality of atoms. In fact there was no precise measurement yet available of the quantitative relation between atoms and the objects of direct scientific experience such as weights, meter sticks, clocks, and ammeters.

To illustrate the dilemma faced by physicists in 1900, consider the highly successful kinetic theory of gases based on the atomic hypothesis and the principles of statistical mechanics from which one can derive the equipartition theorem. The theory showed that the well-measured gas constant R_g in the equation of state of a mole of a gas at low density,

$$PV = R_g T \quad (1)$$

is related to the number of degrees of freedom of the system, $3N$, by the equation

$$R_g = \frac{k(3N)}{3} = kN \quad (2)$$

where N is the number of molecules in one mole (Avogadro’s number), and k is the Boltzmann constant defined so that the mean energy per translational degree of freedom of the molecules in a quantity of gas in thermal equilibrium at absolute temperature T is $kT/2$. At the turn of the century, nobody knew how to measure precisely either k or N . What was required was either some delicate scheme in which the fundamental granularity of atomic phenomena could be detected and precisely measured above the smoothness that results from the huge number of atoms in even the tiniest directly observable object, or a thermodynamic system with a measurable analog of gas pressure and a countable number of degrees of freedom.

The Millikan oil drop experiment of 1910 was a delicate scheme by which the quantum of charge was accurately measured. It compared the electrical and gravitational forces on individual charged oil droplets so tiny that the effect of a change in charge by one or a few elementary

charges could be directly seen and measured through a microscope. The result was a precise determination of e which could be combined with the accurately known values of various combinations of the atomic quantities such as the Faraday (N_e), e/m , atomic weights, and the gas constant (kN), to obtain precise values of N , k , and other atomic quantities. Therefore, a current will not be continuous in the mathematical sense, it should exhibit a “noise” due to the granularity of charges.

Twenty years later Johnson discovered an analog of gas pressure in an electrical system, namely, the mean square “noise” voltage across a conductor due to thermal agitation of the electrical modes of oscillation which are coupled to the thermal environment by the charge carriers. Nyquist showed how to relate that mean square voltage to the countable number of degrees of freedom of electrical oscillations in a transmission line. The only atomic constant that occurs in Nyquist’s theoretical expression for the Johnson noise voltage is the Boltzmann constant k . A measurement of Johnson noise therefore yields directly an experimental determination of k .

In classical statistical mechanics, $k/2$ is the constant of proportionality between the Kelvin temperature of a system in thermal equilibrium and the average energy per dynamical degree of freedom of the system. Its ultimate quantum physical significance emerged only with the development of quantum statistics after 1920 [2]. A summary of the modern view is given below (see reference [2], Kittel and Kroemer, for a lucid and complete exposition).

2.2. Entropy and Temperature

A closed system of many particles exists in a number of distinct quantum states consistent with conservation constraints of the total energy of the system and the total number of particles. For a system with g accessible states, the fundamental entropy σ is defined by

$$\sigma = \ln g \quad (3)$$

With the addition of heat, the number of states accessible within the limits of energy conservation rises, and the entropy increases. An exact enumeration of the quantum states accessible to a system composed of many non-interacting particles in a box and having some definite energy can be derived from an analysis based on the solutions of the Schrödinger equation (Ref. [2], p 77). It shows that for one mole of a gas at standard temperature and pressure (273K, 760 mm Hg) σ is of the order of 10^{25} . The corresponding value of g is of the order of the huge number $e^{10^{25}}$!

Suppose that the total energy U of the system is increased slightly by ΔU , perhaps by the addition of heat, while the volume V and number of particles N are held constant. With the increase in energy more quantum states become accessible to the system so the entropy is

increased by $\Delta\sigma$. The fundamental temperature is defined by

$$\frac{1}{\tau} \equiv \left(\frac{\partial\sigma}{\partial U} \right)_{N,V} \quad (4)$$

The units of τ are evidently the same as those of energy. Since an increase in the energy of one mole of gas by one joule causes a very large increment in σ , the magnitude of τ in common circumstances like room temperature must be much less than 1. In practical thermometry, the Kelvin temperature T is proportional to τ , but its scale is set by defining the Kelvin temperature of the triple point of water to be exactly 273.16 K. This puts the ice point of water at 273.15 K and the boiling point 100 K higher at 373.15 K. The constant of proportionality between fundamental and Kelvin temperatures is the Boltzmann constant, i.e.

$$\tau = kT \quad (5)$$

where $k = 1.38066 \times 10^{-23} JK^{-1}$. By a quantum statistical analysis, based on the Schrödinger equation, of N particles in a box in thermal equilibrium at temperature T , one can then show that the mean energy per translational degree of freedom of a free particle is $\tau/2$ so the total energy of the particles is $\frac{3}{2}N\tau = \frac{3}{2}NkT$ (see [2], p. 72).

Given the quantum statistical definition of τ , the definition of T in terms of τ and the triple point of water, one could, in principle, compute k in terms of the atomic constants such as e , m_e , and h if one could solve the Schrödinger equation for water at its triple point in all its terrible complexity. But that is a hopeless task, so one must turn to empirical determinations of the proportionality constant based on experiments that link the macroscopic and microscopic aspects of the world.

A link between the microscopic and macroscopic was reported by Johnson in 1928 [3] in a paper paired in the Physical Review with one by H. Nyquist [1] that provided a rigorous theoretical explanation based on the principles of classical thermal physics. Johnson had demonstrated experimentally that **the mean square of the voltage across a conductor is proportional to the resistance and absolute temperature of the conductor and does not depend on any other chemical or physical property of the conductor**. At first thought, one might expect that the magnitude of Johnson noise must depend in some way on the number and nature of the charge carriers. In fact Nyquist’s theory involves neither e nor N . It yields a result in agreement with Johnson noise observations and a formula for the mean square of the noise voltage which relates the value of the Boltzmann constant to quantities that can be readily measured by electronic methods and thermometry.

3. NYQUIST'S THEORY OF JOHNSON NOISE

Two fundamental principles of thermal physics are used:

1. The second law of thermodynamics, which implies that between two bodies in thermal equilibrium at the same temperature, in contact with one another but isolated from outside influences, there can be no net flow of heat;
2. The equipartition theorem of statistical mechanics [2], which can be stated as follows:

Whenever the Hamiltonian of a system is homogeneous of degree 2 in a canonical momentum component, the thermal average kinetic energy associated with that momentum is $kT/2$, where T is the Kelvin temperature and k is Boltzmann's constant. Further, if the Hamiltonian is homogeneous of degree 2 in a position coordinate component, the thermal average potential energy associated with that coordinate will also be $kT/2$.

If the system includes the electromagnetic field, then the Hamiltonian includes the term $(E^2 + B^2)/8\pi$ in which E and B are canonical variables corresponding to the q and p of a harmonic oscillator for which (with p and q in appropriate units) the Hamiltonian, is $(q^2 + p^2)/2$.

Nyquist's original presentation of his theory [1] is magnificent; please see the Junior Lab e-library for a copy.

Nyquist invoked the second law of thermodynamics to replace the apparently intractable problem of adding up the average thermal energies in the modes of the electromagnetic field around a conductor of arbitrary shape and composition with an equivalent problem of adding up the average thermal energies of the readily enumerated modes of electrical oscillation of a transmission line shorted at both ends. Each mode is a degree of freedom of the dynamical system consisting of the electromagnetic field constrained by the boundary conditions imposed by the transmission line. According to the equipartition theorem, the average energy of each mode is kT , half electric and half magnetic. The Nyquist formula for the differential contribution dV_j^2 (j for Johnson) to the mean square voltage across a resistor, R , in the frequency interval df due to the fluctuating emfs corresponding to the energies of the modes in that interval is

$$dV_j^2 = 4RkTdf \quad (6)$$

To measure this quantity, or rather its integral over the frequency range of the pass band in the experiment, one must connect the resistor to the measurement device by means of cables that have a certain capacitance C . This

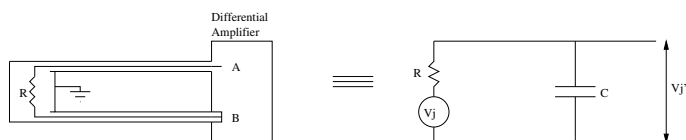

FIG. 1: Equivalent circuit of the thermal emf across a conductor of resistance R connected to a measuring device with cables having a capacitance C

shunts (short circuits) a portion of the signal, thereby reducing its RMS voltage. The equivalent circuit is shown in Figure 1. The differential contribution dV^2 to the signal presented to the input of the measuring device (in our case the A-input of a low-noise differential preamplifier) is a fluctuating voltage with a mean square value

$$dV^2 = 4R_f kT df \quad (7)$$

where

$$R_f = \frac{R}{1 + (2\pi f CR)^2} \quad (8)$$

This equation results from AC circuit theory; see B8 in Appendix B.

Attention was drawn earlier to an analogy between the mean square of the Johnson noise voltage across a conductor and the pressure of a gas on the walls of a container. Both are proportional to kT and the number of degrees of freedom of the system. The big difference between the two situations is that the number of translational degrees of freedom per mole of gas is the "unknown" quantity $3N$, while the number of oscillation modes within a specified frequency interval in the transmission line invoked by Nyquist in his theory is readily calculated from the laws of classical electromagnetism.

Since the Boltzmann constant is related to the number of accessible quantum states, one might well ask:

Where is Planck's constant, h , which fixes the actual number of accessible states?

The answer is that the Nyquist theorem in its original form, like the classical Rayleigh-Jeans formula for the spectral distribution of blackbody radiation, is valid only in the range of frequencies where $hf \ll kT$, in other words, at frequencies sufficiently low that the minimum excitation energy of the oscillations is small compared to kT . At 300K and 100 kHz, $kT = 4 \times 10^{-14}$ ergs (0.04 eV) and $hf = 6 \times 10^{-22}$ ergs. Thus at room temperature kT is $\sim 10^8$ times the minimum energy of an oscillation mode with a frequency near 100 kHz. The exact quantum expression for the mean energy ϵ of each oscillation mode, noted by Nyquist in his paper, is

$$\epsilon = \frac{hf}{e^{hf/kT} - 1} \quad (9)$$

which reduces to $\epsilon = kT$ for $hf \ll kT$ over the range of frequencies and temperatures encountered in this experiment. An example of where this simplification does not

hold true is in the measurement of the cosmic microwave background. In these measurements, a radio telescope is operated at liquid helium temperatures for measurement of the $\sim 2.7K$ cosmic background radiation. The peak of this black body spectrum is around 10^{11} Hz and therefore hf is not much less than kT .

4. EXPERIMENT

In the present experiment you will actually measure an amplified version of a portion of the Johnson noise power spectrum. The portion is defined by the “pass band” of the measurement chain which is determined by a combination of the gain characteristics of the amplifier and the frequency transmission characteristics of the low-pass/high-pass filters that are included in the measurement chain. The filters provide an adjustable and sharp control of the pass band. The combined effects of amplification and filtration on any given input signal can be described by a function of frequency called the effective gain and defined by

$$g(f) = \frac{V_0(f)}{V_i(f)} \quad (10)$$

where the right side is the ratio of the RMS voltage V_0 out of the band-pass filter to the RMS voltage V_i of a pure sinusoidal signal of frequency f fed into the amplifier. **A critical task in the present experiment is to measure the effective gain as a function of frequency of the apparatus used to measure Johnson noise.**

When the input of the measurement chain is connected across the resistor, R , under study, the contribution dV^2 to the total mean square voltage out of the band-pass filter in a differential frequency interval is

$$dV_{meas}^2 = [g(f)]^2 dV^2 \quad (11)$$

We obtain an expression for the measured total mean square voltage by integrating Equation 11 over the range of frequencies of the pass band. Thus

$$V^2 = 4RkTG \quad (12)$$

where the quantity G is the gain integrated over the band-pass region and is given by

$$G \equiv \int_0^\infty \frac{[g(f)]^2}{1 + (2\pi fCR)^2} df \quad (13)$$

The rationale behind this integration is that over any given time interval t , the meandering function of time that is the instantaneous noise voltage across the resistor can be represented as a Fourier series consisting of a sum of sinusoids with discrete frequencies $n/2t$, $n=1, 2, 3, \dots$, each with a mean square amplitude equal to the value specified by the equipartition theorem. When the Fourier series is squared, the cross terms are products

of sinusoids with different frequencies, and their average values are zero. Thus the expectation value of the squared voltage is the sum of the expectation values of the squared amplitudes, and in the limit of closely spaced frequencies as $t \rightarrow \infty$, the sum can be replaced by an integral.

Given the linear dependence of V^2 on T in Eq. 12, it is evident that one can use the Johnson noise in a resistor as a thermometer to measure absolute temperatures. A temperature scale must be calibrated against two phenomena that occur at definite and convenient temperatures such as the boiling and melting points of water, which fix the centigrade scale at 100° C and 0° C, respectively. In the present experiment you will take the centigrade calibrations of the laboratory thermometers for granted, and determine the centigrade temperature of absolute zero as the zero-noise intercept on the negative temperature axis.

5. PROCEDURE OVERVIEW

The experiment consists of the following parts:

1. Calibration of the measurement chain and measurement of $g(f)$;
2. Measurement of $V^2 = V_R^2 - V_S^2$, where V_R = RMS voltage at the output of the band-pass filter with the resistor in place; and V_S = RMS voltage with the resistor shorted); for various resistors and temperatures;
3. Determination of the Boltzmann constant from the data;
4. Determination of the centigrade temperature of absolute zero.

5.1. Suggested Progress Check for end of 2nd Session

Plot the gain curve of your signal chain versus frequency and perform a back of the envelope integration to obtain a value of G . You should also have a few measurements at at least one resistor value: What is your value for k ?

6. EXPERIMENTAL APPARATUS

Figure 3 depicts how you will calibrate your experimental apparatus. Figure 2 is a schematic diagram of the apparatus showing the **resistor** R mounted on the terminals of the aluminum box, shielded from electrical interference by an inverted metal beaker, and connected through switch SW2 to the measurement chain or the ohmmeter. Switch SW1 shorts R . The measurement chain consists of a low-noise differential amplifier, a

band-pass filter, and a digitizing oscilloscope. Sinusoidal calibration signals are provided by a function generator.

The noise you will measure is very small, typically on the order of microvolts. To minimize the problem of electrical interference in the measurement of the low-level noise signals it is essential that all cables be as short as possible. The two cables that connect the resistor to the ‘A’ and ‘B’ input connectors of the differential amplifier should be tightly twisted, as shown, to reduce the flux linkage of stray AC magnetic fields.

The cathode ray tube display in the digital oscilloscope emits a variable magnetic field from its beam-control coil which may have a devastating effect on your measurements unless you keep it far away (≥ 5 feet) from the noise source. Take special care to avoid this problem when you arrange the components of the measurement chain on the bench.

The filter we use is a Krohn-Hite 3BS8TB-1k/50kg band-pass filter. This filter has fixed-frequency band-pass range of 1 kHz to 50 kHz. It has 8 poles, the equivalent of 8 simple filters in series, so the dropoff outside of the cut-off frequencies should be quite sharp. Connect the output of the amplifier to the positive input of the Krohn-Hite Filter. Then connect the output of the filter to the oscilloscope. The filter is equipped with an AC power adapter connector; make sure this is plugged in and that the green LED is lit indicating that the filter is receiving power.

7. DETAILED JOHNSON NOISE PROCEDURE

7.1. Calibrate the measurement chain

The digital oscilloscope can measure the RMS voltage of both periodic and random signals over a dynamic range of somewhat more than 10^3 , from several millivolts to several volts, whereas the Johnson Noise signal is only microvolts. Thus, with the differential amplifier set to a nominal gain of 1000, the microvolt noise signals are amplified sufficiently to be measured in the millivolt range of the oscilloscope. To determine the overall amplification of the amplifier/filter combination, one feeds a sinusoidal test signal with an RMS voltage V_i in the millivolt range to the ‘A’ AC-Coupled (through $0.1\mu\text{F}$, shunted to ground with $100\text{M}\Omega$ and 25pF in parallel) of the SRS preamplifier (with the source set to ‘A’), and measure the RMS voltage V_0 of the filter output using the digitizing oscilloscope. The gain of the system at the frequency of the test signal is $g(f) = V_0/V_i$.

IMPORTANT: Turn on transients exist - set the input coupling switches of the SRS preamplifier to GND before turning on the device and before making any connections to another device. Do not transfer from the GND settings until after all connections are completed.

At the voltage preamplifier, the maximum input signal in differential mode is 1V DC and $3V_{PP} \approx 1V_{RMS}$ AC. Do not exceed these values! Excessive common-mode

inputs can “turn on” low conduction paths at the input of the preamplifier to protect the input circuits, and thereby lower the input impedance.

The “roll-off” frequencies selectable from the front panel indicate 3dB points in a 6 dB/octave roll off curve. The output impedance of the preamplifier is 600Ω and can produce a maximum of 10V pk-pk ahead of 600Ω . Be careful about your terminations!

The SRS preamplifier has rechargeable batteries which ‘trickle charge’ when the unit is plugged into the wall (and very much slower when the unit is in the ON position than when it is in the OFF position. You can use this feature if you want; it may reduce extraneous noise a bit. To operate from battery power, set the power switch to ON, but do not plug in the line cord. Be sure to plug in the line cord after your session is over to ensure that the next group has a fully charged set of batteries!

Measure the variation of the test signal RMS voltage and the gain of the measurement chain as a function of frequency and produce a rough plot in your lab notebook

Configure the function generator to output a sine wave with an RMS amplitude of 20mV. Use the Kay 837 attenuator with 26 dB (1/20) of attenuation to produce a sinusoid in the millivolt range. Use a BNC tee to simultaneously send this signal into the digitizing oscilloscope and into the ‘A’ (AC-Coupled) input of the amplifier with the source set to ‘A’.

The output of the amplifier should then be fed into the band-pass filter. Before taking detailed measurements of $g(f)$, you’ll want to make sure that filter is behaving in the way you expect it should. Spend a few moments varying the frequency of the function generator to observe the behavior below 1kHz, above 50 kHz and in between.

Without touching the amplitude control of the function generator, measure and record RMS voltages for both V_i (out of the attenuator) and V_0 (out of the band-pass filter) over the range that will pass the filter ($\sim 0.5\text{kHz}$ to $\sim 80\text{kHz}$).

Plot $[g(f)]^2$ against f as you go along to check the consistency and adequacy of your data.

1. Set the oscilloscope to display both the V_i and V_0 sinusoids. Use the oscilloscope Voltage measurement options to measure the RMS voltage of each channel. The RMS of V_i should remain essentially constant throughout the measurement of $g(f)$. However, you will want to keep an eye on it during the process of this measurement to ensure that this is the case.
2. Turn on the bandwidth limit on for the channel which is measuring V_i .
3. Make sure the inputs are set to AC coupling to eliminate any DC offset in the signals you are measuring.

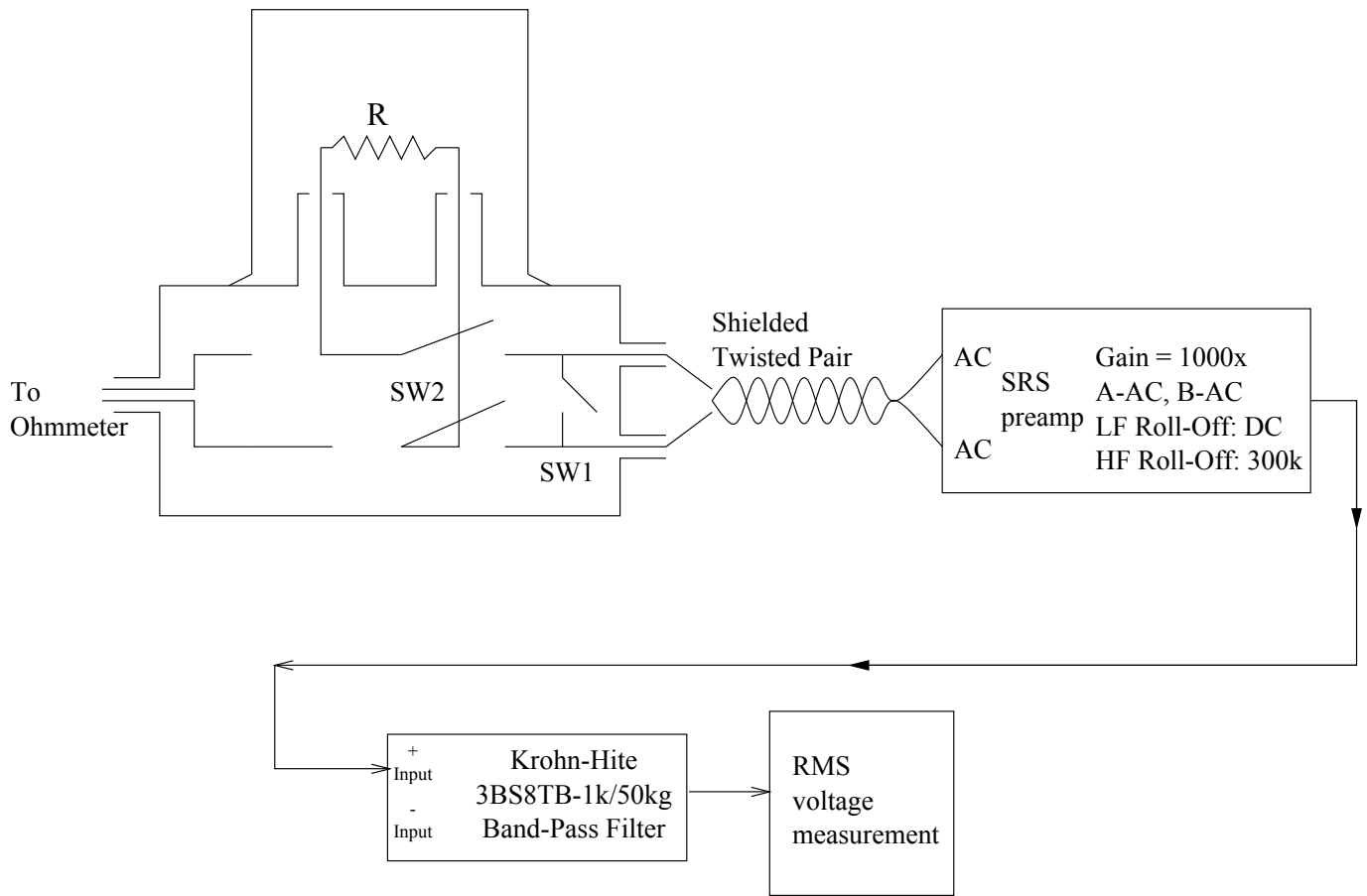

FIG. 2: Block diagram of the electronic apparatus for measuring Johnson noise.

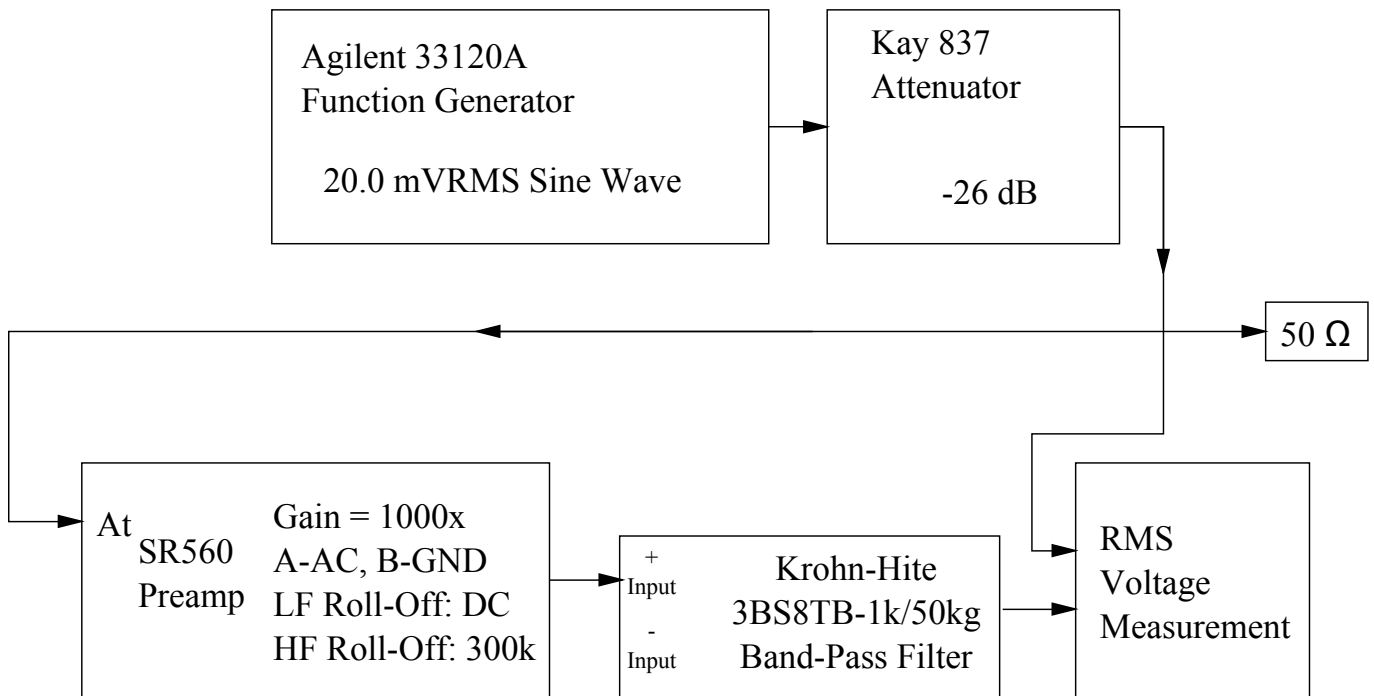

FIG. 3: Block diagram of the electronic apparatus for calibrating the Johnson Noise experiment

4. Press 'DISPLAY', and select 'AVG 256' (Note: Later, when you take noise measurements, you must select 'normal' instead of averaging since the RMS voltage of the average of n random wave forms approaches zero as $n \rightarrow \infty$. On the other hand, the RMS voltage of the average of many wave forms consisting of a constant sinusoid plus random noise approaches the RMS voltage of the pure sinusoid.)
5. Adjust the digital scope amplitude and sweep-speed controls so that several ($\sim 5-10$) cycles of the sinusoid appear on the screen.

To reduce errors of measurement and obtain an error assessment, you can make repeated measurements. Record the V_{rms} and frequency displayed at the bottom of the screen; repeat n times (e.g., $n=5$) at each setting. For each setting, compute the mean V_{rms} , and the standard error of the mean ($= \frac{\sigma}{\sqrt{n-1}}$).

Because the oscilloscope is in averaging mode, you will want to wait several moments for transient signals to average out before taking a reading after changing the frequency or adjusting anything on the scope. Wait until you see that V_i and V_0 have leveled off in their fluctuations before pressing 'stop' to take data.

NOTE: It is very important that you keep your measurement chain in the same configuration for making both gain curve and Johnson Noise measurements. Be careful not to change any settings on the amplifier in between these two measurements (one helpful tip for making sure the gain of the amplifier is consistent between measurements taken on different days is to turn the red 'CAL' knob all the way counter-clockwise until it clicks).

7.2. Measure V^2 for a variety of resistors

When you use the apparatus to measure the Johnson Noise across a resistor, about half the RMS voltage is noise generated in the amplifier itself. Interference pickup may vary. Since all the contributions to the measured RMS voltage are **statistically uncorrelated, they add in quadrature**. To achieve accurate results it is essential to make repeated measurements with each resistor with the shorting switch across the conductor alternately opened and closed. The measure of the mean square Johnson noise is

$$V^2 = V_R^2 - V_S^2 \quad (14)$$

where V_R and V_S are the RMS voltages measured with the shorting switch open and closed, respectively.

Measure the Johnson noise at room temperature in ~ 10 metal film and/or wire-wound resistors with values from 10^4 to 10^6 ohms. Mount the resistors in the alligator clips projecting from the aluminum test box equipped with a single-pole-single-throw (SPST) shorting switch, a double-pole-double-throw (DPDT) routing switch, and

connections for a thermistor for use in the later temperature measurement. Cover the resistor and its mounts with a metal beaker to shield the input of the system from electrical interference. After each noise measurement measure the resistance of the resistor: plug a digital multimeter into the pin jacks on the aluminum box and flip the DPDT switch on the sample holder to the resistance measuring position. Before each noise measurement, be sure to disconnect the multimeter (to avoid introducing extraneous electrical noise) and flip the DPDT switch back to the noise-measurement position.

Be thoughtful about how you are using the digitizing oscilloscope to measure the RMS voltages for V_R and V_S . Again, you should use AC coupling to eliminate any DC offset. Also, you will need to be intentional about both the time and voltage scales that you choose. The range of voltages the scope is able to digitize is the range shown on the screen so you will want to fill the screen without cutting the max/min off. Be sure not to choose too small a vertical range and in the process cut off your signal!

Keep in mind, that you will want to use only one setting of the voltage scale for all your measurements of V_R and V_S for all resistors that you sample. To make sure you have an appropriate setting, you might want to look at V_R for your highest value of resistance first. As for the time axis, a setting in the range of $500\mu s$ to $5ms$ per division should work well.

A good way to determine the appropriate scale for a given resistor is to set the scope to measure V_{max} , take several readings of this value and make sure it is well contained ($\leq 75\%$) in the total range currently displayed. You can also do this visually by looking for the smallest scale that appears to contain all the noise fluctuations within the first three out of the four divisions above or below the baseline.

Values of V_S should remain essentially constant over all values of resistance. However, subtle changes in your experimental configuration or procedure could cause V_S to fluctuate. For instance, even the orientation of one of your cables or whether or not you are touching the cable can yield different results in your measurements. Strive to keep things as consistent as possible throughout a particular series of measurements. Additionally, it is a good idea to keep an eye on V_S and record its value each time you measure V_R .

As during your calibration measurements, you will want to repeat each measurement at least five times to reduce random errors and obtain an error assessment for your measurements.

According to equation 12, the value of Boltzmann's Constant, k , can be expressed in terms of measured quantities and G , which is a function of R and C :

$$k = \frac{V^2}{4RTG} \quad (15)$$

So in order to calculate k from your measurements of the Johnson Noise, you will also need to measure the capacitance, C , seen by the resistor. The SRS preamplifier

has an input capacitance of 25pF. With this knowledge in hand, you will still need to determine the capacitance contributed by the switching box and the cables connecting it to the amplifier. Alternatively, you could simply measure the capacitance of all these components and the amplifier simultaneously.

A BK Precision 875A LCR Meter is provided for this purpose. First use it to measure some known capacitance by inserting a plain capacitor directly. Once you have convinced yourself that the meter is functioning properly and that you know how to read it, devise a way to measure **the same capacitance that the resistor sees**. Remember, capacitance is determined by the geometry of the conductors and dielectrics in the circuit so it is very important to have things in the exact same configuration for this measurement as you did for measurements of the Johnson Noise. Also be aware that any cables you use to connect the LCR meter to measurement chain will contribute their own capacitance.

Be sure to make an assessment of the uncertainty in your measurement of C . Calculate values of k for several values of C based on this uncertainty. You will have uncertainty associated with the the quantities V^2 , R , and C . You will need to propagate these errors in order to determine your uncertainty in k .

The factor G must be recalculated by numerical integration for each new trial value of R and C . In principle, if you use the correct value of C in your calculations of G , then the values of k obtained from Equation 15 should cluster around a mean value close to the value for $R \rightarrow 0$ and should not vary systematically with R . Using the best values of k and C derived in this way, you can plot experimental and theoretical curves of V^2/R against R for comparison.

Question: What happens as $R \rightarrow \infty$?

7.3. Measure Johnson noise as a function of temperature

Measure the Johnson noise in a resistor over a range of temperatures from that of liquid nitrogen (77 K) to $\sim 150^\circ\text{C}$. Clip a resistor to the alligator clips and invert the assembly into a dewar filled with liquid nitrogen. Ask a technical instructor for help in dispensing the nitrogen and make sure to wear eye protection and gloves.

To make a high temperature measurement, invert the assembly into the cylindrical oven, heated by a variac supply set to ~ 40 VAC. Note, it will take some time for the temperature to equilibrate and stabilize within the oven. You can take advantage of this slow process to measure the resistance, the RMS voltages of the Johnson noise and the background as the temperature rises. Try to disturb the setup as little as possible to prevent the loss of heated air and a subsequent change in the resistors temperature. Use the delicate glass immersion thermometer (range = 0 - 250°C) to monitor the temperature of the air bath. **Do not allow the temperature**

of the oven to exceed 150°C as this can damage the wire insulation within the probe.

According to the Nyquist theory the points representing the measured values of $V^2/4RG$ plotted against T ($^\circ\text{C}$ degrees) should fall on a straight line with a slope equal to the Boltzmann constant, and an intercept on the temperature axis at the centigrade temperature of absolute zero. Note that if the resistance of the conductor varies significantly with temperature, then G must be evaluated separately at each temperature, i.e. the integral of Equation 13 must be evaluated for each significantly different value of the resistance.

1. Make a plot of $V^2/4RG$ against T (in $^\circ\text{C}$ degrees).
2. Derive a value and error estimate of k from the slope of the temperature curve.
3. Derive a value and error estimate of the centigrade temperature of absolute zero.

8. SHOT NOISE

A current source in which the passage of each charge carrier is a statistically independent event (rather than a steady flow of many charge carriers) necessarily delivers a “noisy” current, i.e., a current that fluctuates about an average value. Fluctuations of this kind are called “shot noise”. The magnitude of such fluctuations depends on the magnitude of the charges on the individual carriers. Thus a measurement of the fluctuations should, in principle, yield a measure of the magnitude of the charges.

Consider a circuit consisting of a battery, a capacitor in the form of a photo-diode, a resistor, and an inductor, connected in series as illustrated in Figure Ca. Illumination of the photo-diode with an incoherent light source causes electrons to be ejected from the negative electrode in a random sequence of events. Each ejected photo-electron, carrying a charge of magnitude e , is accelerated to the positive electrode and, during its passage between the electrodes it induces an increasing current in the circuit, as shown in Figure Cb.

When the electron hits the positive plate the current continues briefly due to the inductance of the circuit and a damped oscillation ensues. The shape of the current pulse depends on the initial position, speed and direction of the photo-electron as well as the electrical characteristics of the circuit. The integral under the curve is evidently the charge e . If the illumination is strong enough so that many events occur during the duration of any single electron pulse, then the current will appear as in Figure 5, in which the instantaneous current $I(t)$ fluctuates about the long-term average current I_{av} .

In this part of the experiment you will measure, as a function of I_{av} , the mean square voltage of the output of an amplifier and a band-pass filter system whose input is the continuously fluctuating voltage across R_F .

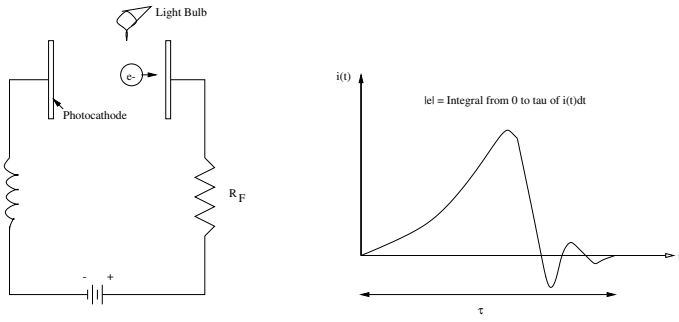

FIG. 4: (a) Schematic diagram of a circuit in which the current consists of a random sequence of pulses generated by the passage of photoelectrons between the electrodes of a photodiode. (b) Schematic representation of the current pulse due to the passage of one photo-electron.

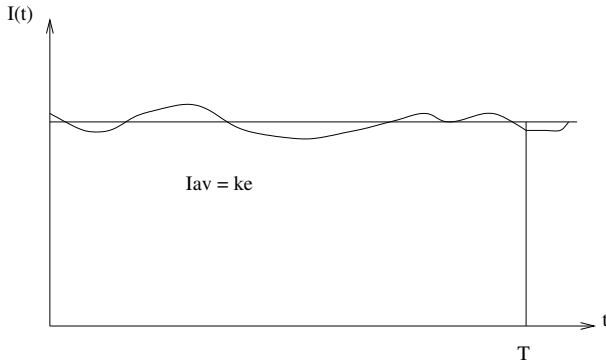

FIG. 5: Plot of a fluctuating current against time with a straight line indicating the long-term average current.

According to the theory of shot noise, a plot of this quantity against the average current should be a straight line with a slope proportional to e . The problem is to figure out what the proportionality factor is.

8.1. THEORY OF SHOT NOISE

The integral under the curve of current versus time for any given pulse due to one photo-electron event is e , the charge of the electron. If the illumination is constant and the rate of photoelectric events is very large, then the resulting current will be a superposition of many such waveforms $i_k(t)$ initiated at random times T_k with a “long term” average rate we will call K , resulting in a fluctuating current with an average value $I_{av} = Ke$, as illustrated in Figure 5. The fluctuating component of such a current was called “shot noise” by Schottky in 1919, who likened it to the acoustic noise generated by a hail of shot striking a target.

The fluctuating current is

$$I(t) = \sum_k i_k(t) \quad (16)$$

and its mean square during the time interval T is

$$\langle I^2 \rangle = \frac{1}{T} \int_0^T [\sum_k i_k(t)]^2 dt \quad (17)$$

The problem is to derive the relation between the measurable properties of the fluctuating current and e . Although the derivation is somewhat complicated (see Appendix C), the result is remarkably simple: within the frequency range $0 < f \ll \frac{I_{av}}{e}$, the differential contribution to the mean square of the total fluctuating current from fluctuations in the frequency interval from f to $f + df$ is (see Appendix B)

$$d\langle I^2 \rangle = 2eI_{av}df \quad (18)$$

Suppose the fluctuating current flows in a resistor of resistance R_F connected across the input of an amplifier-filter combination which has a frequency-dependent gain $g(f)$. During the time interval T , the voltage developed across the resistor, IR_F , can be represented as a sum of Fourier components with frequencies $m/2T$, where $m = 1, 2, 3, \dots$, plus the zero frequency (DC) component of amplitude $I_{av}R_F$. Each component emerges from the amplifier-filter with an amplitude determined by the gain of the system for that frequency. The mean square of the sum of Fourier components is the sum of the mean squares of the components (because the means of the cross terms are all zero). Thus, in the practical limit of a Fourier sum over closely spaced frequencies, we can express the mean square voltage of the fluctuating output signal from the amplifier-filter as the integral

$$V_0^2 = 2eI_{av}R_F^2 \int_0^\infty [g(f)]^2 df + V_A^2 \quad (19)$$

where V_A^2 has been added to represent the constant contributions of the amplifier noise, and Johnson Noise in R_F , to the total mean square voltage, and where the DC term is omitted because the DC gain of the amplifier-filter is zero.

To get a feel for the plausibility of the shot noise formula one can imagine that the current in the photodiode circuit is a step function representing the amount of charge ne released in each successive equal time interval of duration τ divided by τ , i.e., the mean current in each interval $\frac{ne}{\tau}$. The expectation value of n is $\langle n \rangle = K\tau$. We assume there is no statistical correlation between the numbers of events in different intervals. According to Poisson statistics the variance of n (mean square deviation from the mean) is the mean, i.e.,

$$\langle (n - \langle n \rangle)^2 \rangle = \langle n^2 \rangle - \langle n \rangle^2 = \langle n \rangle = K\tau \quad (20)$$

It follows that the mean square value of the current over time would be

$$\langle I^2 \rangle = \left\langle \left(\frac{ne}{\tau} \right)^2 \right\rangle$$

$$\begin{aligned}
&= \left(\frac{e}{\tau}\right)^2 \langle n^2 \rangle \\
&= \left(\frac{e}{\tau}\right)^2 [\langle n \rangle + \langle n \rangle^2] \\
&= \frac{eI_{av}}{\tau} + I_{ave}^2
\end{aligned} \tag{21}$$

which shows that the fluctuating term is proportional to eI_{av} as in the exact expression for the differential contribution, Equation 18.

Actually the current at any given instant from an illuminated photo-diode is the sum of the currents due to the photoelectrons ejected during the previous brief time interval. Thus the currents at any two instants separated in time by less than the duration of the individual pulses are not statistically independent. Moreover, the simple scheme provides no handle on the frequency spectrum of the noise which one must take into account in evaluating the response of the measurement chain. One approach to a rigorous solution is presented in Appendix B. Others are possible.

9. SHOT NOISE EXPERIMENTAL PROCEDURE

The procedure has three parts:

1. Calibration of the gain of the measurement chain as a function of frequency;
2. Measurement of the mean square noise voltage at the output of the measurement chain as a function of the average current in the diode circuit as it is varied by changing the intensity of illumination.
3. Calculation of the charge of the photoelectrons.

9.1. CALIBRATION OF THE MEASUREMENT CHAIN

Figure 7 is a block diagram of the electronic apparatus, and Figure 6 is a diagram of the diode circuit and preamplifier. The current $I(t)$ in the photo-diode circuit is converted to a voltage $V = IR_F$ at the point indicated in Figure 6 by the operational amplifier with precision feedback resistors in the first stage of the preamplifier inside the photodiode box. This voltage is filtered to remove frequencies <100 Hz and is fed to the second stage where it is amplified by a factor of ~ 10 . The output signal is further amplified by the filtering preamp, then filtered by the 8-pole bandpass filter, before being measured by the RMS voltmeter.

There are two methods for measuring the output signal from the photo-diode box. The first is a digital oscilloscope; it gives a qualitative view of the signal, useful for

debugging, and can perform signal averaging. This is useful for the calibration phase, but averaging the shot noise would be counterproductive. If you choose to measure the noise with this method, make sure to put the oscilloscope trigger to “auto” and move the trigger threshold above the signal to avoid a skewed data set. The Agilent oscilloscopes in lab have a measurement accuracy of at most 3 digits, which is a bit low. The second method uses multimeters. Multimeters allow you to select the AC or DC part of the signal. The big advantage is the number of digits given: the Agilent multimeters have $6\frac{1}{2}$ digits, giving better measurement precision. A combination of the two methods is also useful.

The photo-diode box has a test input for calibration of the overall gain of the measurement chain as a function of the frequency. The typical shot noise RMS voltage across the precision resistor R_F is of the order of 10 microvolts. Since the gain of the circuit in the photo-diode box is ~ 10 , a gain of 100 in the amplifier will yield a total gain of 10^3 and bring the signal in the pass band of the filter up to the ~ 10 millivolt level that can be readily measured by the digitizing oscilloscope. As in the Johnson noise calibration, you can determine the effective gain of the amplifier-filter system as a function of frequency by feeding a millivolt sinusoid signal of measured RMS voltage from the function generator into the test input of the phototube box and measuring the RMS voltage of the signal out of the filter.

9.1.1. Calibration

Select the sine wave output of the function generator, set the the RMS voltage to ~ 20 mV, and feed the signal directly to the digitizing oscilloscope. Without touching the amplitude control on the function generator, measure the RMS voltage for several frequencies over the range of the filter band pass and plot the result so you have a handy data base for the subsequent gain measurements.

Measure the gain of the measurement chain as a function of frequency. Make sure the photo-diode voltage is switched off so that it behaves as an open circuit with no photoelectric current. Switch on the amplifier voltage on the photo-diode box. Feed test signals of various frequencies into the ‘test input’ and measure the RMS voltage at the output of the bandpass filter. Experiment with the scope settings to obtain higher precision results. Plot the values of g^2 as you go along to assess where you need more or less data to define accurately the gain-squared integral.

9.2. MEASUREMENT OF THE AVERAGE CURRENT AND THE CURRENT NOISE

Remove the cable from the test input and cover the input plug with the cap provided to short the input to ground. This creates a path for current to travel from

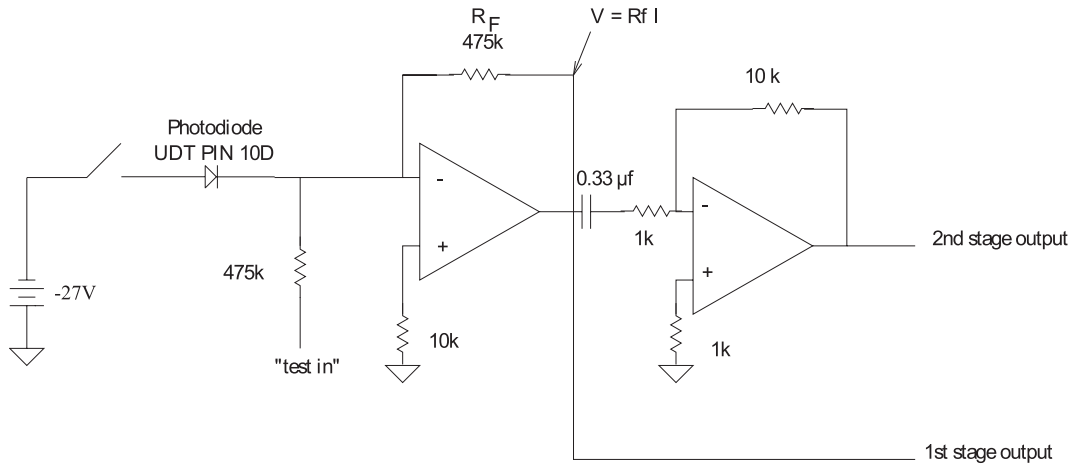

FIG. 6: Diagram of the photo-diode and preamplifier circuit.

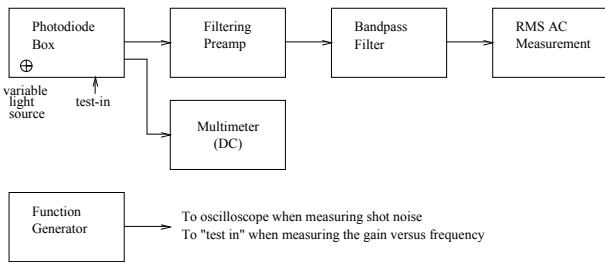

FIG. 7: Block diagram of the experimental arrangement for measuring shot noise.

ground, through the resistor, into the illuminated diode. Set the multimeter to measure DC voltage and plug it into the “first stage output” to measure the voltage $R_F I$. Leave the rest of the measurement chain just as it was when you calibrated it.

There are two banana plug ports to measure the current to the light bulb. It is a good idea to check the current before you start. The current should change as you adjust the potentiometer knob, but make sure that the current does not exceed 300 mA to avoid damaging the light bulb. If the switch is on and there isn't a change in current as you twist the knob, the light bulb or the batteries are probably dead. Once you finish with this check, it is a good idea to short the two ports to reduce extraneous noise.

Record the RMS voltage from stage 2 and the DC voltage from stage 1 for various settings of the light bulb knob. Many repeated measurements at each light intensity will beat down the random errors.

10. ANALYSIS

Plot V_0^2 as a function of the combined quantity

$$2R_F^2 I_{av} \int_0^\infty g^2(f) df \quad (22)$$

From the slope of this line determine the charge on the electron.

10.1. Possible Theoretical Topics

- The Nyquist theorem.
- Shot noise theory

Some useful references for this lab include [4–8].

11. EQUIPMENT LIST

Manufacturer	Description	URL
Agilent	Oscilloscope and Multimeters	agilent.com
SRS	SR560 Preamplifier	thinksrs.com
Kron-Hite	8-Pole Band-Pass Filter	kron-hite.com
Kay	Precision Attenuator	

[1] H. Nyquist, *Phys. Rev.* **32**, 110 (1928).

[2] C. Kittel and H. Kroemer, *Thermal Physics* (Freeman, New York, 1980).

[3] J. Johnson, *Phys. Rev.* **32**, 97 (1928).

[4] F. Reif, *Fundamentals of Statistical and Thermal Physics* (McGraw-Hill, New York, 1965), chap. 15, pp. 582–587.

[5] H. C. Kittel, W.R. and R. Donnelly, *Am. J. Phys.* **46**, 94 (1978).

- [6] S. Goldman, *Frequency Analysis, Modulation and Noise* (McGraw-Hill, 1948).
- [7] M. Schwartz, *Information Transmission, Modulation and Noise* (McGraw-Hill, New York, 1959).
- [8] A. V. D. Ziel, *Noise in Measurement* (1976), chap. 3.2-3.3, pp. 30–38.

Appendix A: A Mechanical Experiment to determine k

Before turning to a detailed consideration of the Johnson noise experiment, it is amusing to consider the possibility of a mechanical determination of k with a macroscopic system having one degree of freedom, namely a delicate torsion pendulum suspended in a room in thermal equilibrium (i.e. no drafts, etc.) at temperature T . The degree of freedom is the angular position θ with which is associated the potential energy $\frac{1}{2}\kappa\theta^2$. According to the equipartition theorem (see below), the mean thermal potential energy is

$$\frac{1}{2}\kappa\langle\theta^2\rangle = \frac{1}{2}kT \quad (\text{A1})$$

where κ is the torsion constant of the suspension, and $\langle\theta^2\rangle$ is the mean square angular displacement of the pendulum from the equilibrium orientation. Thus, in principle, by measuring $\langle\theta^2\rangle$ over a time long compared to the period, one can determine k . To judge what this might require in practice, imagine a torsion balance consisting of a tiny mirror (for reflecting a laser beam) suspended by a 0.5 mil tungsten wire 10 feet long. Such a suspension has a torsion constant of the order of 10^{-3} dyne cm rad $^{-1}$. According to Equation A1, at 300 K the value of $\langle\theta^2\rangle^{1/2}$, i.e. the RMS value of the angular deflection, would be about 1 arc second. Such an experiment might be possible, but would be exceedingly difficult.

Appendix B: DERIVATION OF THE RMS THERMAL VOLTAGE AT THE TERMINALS OF AN RC CIRCUIT

Figure B shows the circuit equivalent to the resistor and coaxial cables that are connected to the PAR preamplifier for the measurement of Johnson noise. The equivalent circuit consists of a voltage source of the fluctuating thermal emf V in series with an ideal noiseless resistor of resistance R and a capacitor of capacitance C . According to Faraday's Law, the integral of the electric field around the RC loop is zero, so

$$V = IR + \frac{Q}{C} \quad (\text{B1})$$

According to charge conservation (from Ampere's Law and Gauss' Law), the current into the capacitor equals the rate of change of the charge on the capacitor, so

$$I = \frac{dQ}{dt} \quad (\text{B2})$$

We seek an expression in terms of $d\langle V^2\rangle$, R , and C for the contribution to the RMS voltage across the terminals in a narrow frequency range, i.e.

$$d\langle V^2\rangle = d\langle Q^2\rangle/C \quad (\text{B3})$$

Consider one Fourier component of the fluctuating thermal emf across the resistor, and represent it by the real part of $\nu_J = \nu_0 e^{j\omega t}$, where $j = \sqrt{-1}$. The resulting current is the real part of $i = i_0 e^{j\omega t}$, the charge on the capacitor is the real part of its integral $q = -(j/\omega)i$, and the desired output voltage is the real part of $\frac{q}{C} = -(\frac{j}{\omega C})i$. Substituting the expressions for i and q into Equation B1 and canceling the time-dependent terms, we find

$$\nu_0 = (R - \frac{j}{\omega C})i_0 \quad (\text{B4})$$

Solving for i_0 we obtain the relation

$$i_0 = \frac{\nu_0}{R - \frac{j}{\omega C}} \quad (\text{B5})$$

so

$$\nu'_J = \frac{q}{C} = -(\frac{j}{\omega C})i = \frac{-j\nu_J}{\omega RC - j} \quad (\text{B6})$$

The statistically independent contribution which this mode gives to the measured total mean square noise voltage is the square of its amplitude which we find by multiplying ν'_J by its complex conjugate:

$$\langle\nu'^2_J\rangle = \frac{\langle\nu^2_J\rangle}{1 + (\omega RC)^2} \quad (\text{B7})$$

Summing all such contributions in the differential frequency range df , we obtain

$$\langle dV^2\rangle = 4R_f kT df \quad (\text{B8})$$

where

$$R_f = \frac{R}{1 + (2\pi f RC)^2} \quad (\text{B9})$$

Appendix C: DERIVATION OF THE SHOT NOISE EQUATION

Following is an abbreviated version of the shot noise theory given by Goldman (1948). We begin by expressing the current in the photodiode circuit due to a single event that occurs at time T_k , like that depicted in Figure Cb, as a Fourier series over a long time interval from 0 to T . Calling this current pulse $i(t - T_k)$ we represent it as a Fourier series:

$$i(t - T_k) = \frac{a_0}{2} + \sum_{n=1}^{\infty} \left(a_n \cos \frac{2\pi n t}{T} + b_n \sin \frac{2\pi n t}{T} \right) \quad (\text{C1})$$

where

$$a_0 = \frac{2}{T} \times \int_0^T i(t - T_k) dt = \frac{2e}{T} \quad (\text{C2})$$

$$a_n = \frac{2}{T} \times \int_0^T i(t - T_k) \cos \frac{2\pi n t}{T} dt = \frac{2e}{T} \cos \frac{2\pi n T_k}{T} \quad (\text{C3})$$

$$b_n = \frac{2}{T} \times \int_0^T i(t - T_k) \sin \frac{2\pi n t}{T} dt = \frac{2e}{T} \sin \frac{2\pi n T_k}{T} \quad (\text{C4})$$

with $i(t - T_k) = e\delta(t - T_k)$.

The area under the curve in Figure Cb is the charge e of one electron; it represents the ‘‘impulse’’ of the shot, and is accounted for in the Fourier representation by the lead term in the series whose coefficient is given by Equation C2. To justify Equations C3 and C4 in the context of the present experiment we note that the gain of the amplifier-filter system used in this measurement is different from zero only for frequencies such that $f = n/T \ll 1/\tau$. Consequently we can confine our calculation of the Fourier coefficients to those for which $n\tau \ll T$. It follows that the cos and sin factors in the integrands of equations C3 and C4 do not vary significantly over the range of t in which $i(t - T_k)$ differs from 0, and that they can therefore be taken outside their integrals with their arguments evaluated at the instant of the event. In other words, the function representing the current impulse of a single event acts like a delta-function. Substituting the expressions for a_0 , a_n , and b_n from equations C2, C3, and C4 into C1 we obtain

$$i(t - T_k) = \frac{e}{T} + \frac{2e}{T} \sum_{n=1}^{\infty} \cos \left[\frac{2\pi n(t - T_k)}{T} \right]. \quad (\text{C5})$$

We suppose now that many such events pile up to produce the total current at any given instant. We seek a way to add the currents due to the individual events to obtain the differential contribution $d\langle I_0^2 \rangle$ in the frequency interval df to the mean square of the sum. We use the well known fact that the mean square of the sum of all the Fourier components is the sum of the mean squares of the individual components (the mean values of the

cross-frequency terms in the squared Fourier series are all zero). The quantity $d\langle I_0^2 \rangle$ is therefore the sum of the mean squares of the individual contributions in the frequency range df . To evaluate it we first focus attention on the n^{th} Fourier component which we represent by

$$c_n \cos \left(\frac{2\pi n t}{T} - \phi_n \right) \quad (\text{C6})$$

to which the k^{th} event contributes the quantity

$$\frac{2e}{T} \cos \left(\frac{2\pi n(t - T_k)}{T} \right) \quad (\text{C7})$$

The mean square value of the n^{th} component is c_n^2 so our immediate problem is to evaluate the quantity c_n^2 . Since the events occur at random times from 0 to T , their contributions to the n^{th} component have random phases which are distributed uniformly from 0 to 2π . Consequently, we must add them as vectors. To do this we first group them according to their phase. The expected number with phases between ϕ and $\phi + d\phi$ is $\frac{d\phi}{2\pi} KT$.

$$q = \frac{d\phi}{2\pi} KT \quad (\text{C8})$$

Combining this with equations C6 and C7, we find that the average value of the sum of the contributions with phase angles in the range from ϕ to $\phi + d\phi$ for the Fourier component of frequency n/T is

$$\frac{d\phi}{2\pi} KT \frac{2e}{T} \cos \left(\frac{2\pi n t}{T} - \phi \right) = \frac{Ke}{\pi} \cos \left(\frac{2\pi n t}{T} - \phi \right) \quad (\text{C9})$$

We now represent each one of the preliminary sums given by equation C8 by a differential vector in a two dimensional phase diagram. Added head to tail in order of increasing phase, these vectors form a closed circular polygon of many sides. If instead of the exact expected numbers of events contributing to each differential vector, we use the actual numbers q_1, q_2, \dots , then, in general, the polygon will not quite close due to statistical fluctuations in these numbers. The line segment that closes the gap is the overall vector sum for this particular Fourier component. It will have a random direction and a tiny random length that represents the net effect of the fluctuations. Its x and y components will have zero expectation values, but finite variances (mean square values). Each contribution to the total x component is a number of events that obeys a Poisson distribution with a variance equal to its expectation value. By a well known theorem of statistics (used frequently in error analysis), the variance of the sum is the sum of variances. Thus the mean square of the x component of the vector representation of the n^{th} Fourier component is

$$\frac{4e^2}{T^2} (q_1 \cos^2 \phi_1 + q_2 \cos^2 \phi_2 + \dots) =$$

$$\begin{aligned}
&= \frac{4e^2 KT}{T^2} \frac{1}{2\pi} \int_0^{2\pi} \cos^2 \phi d\phi \\
&= \frac{2e^2 K}{T} \quad (C10)
\end{aligned}$$

The mean square of the y components has the same value. And since the vector itself is the hypotenuse of the right triangle formed by the x and y components, the mean square of its length is the sum of the mean squares of the two components. Thus

$$\langle c_n^2 \rangle = \frac{4e^2 K}{T} \quad (C11)$$

and it follows that the contribution of the n^{th} Fourier component to $d\langle I_0^2 \rangle$ is $\frac{\langle C_n^2 \rangle}{2} = \frac{2e^2 K}{T}$. The frequency of the n^{th} component is $f = n/T$, so the number of Fourier components corresponding to a frequency bandwidth df is $dn = Tdf$. Therefore the contribution to the mean square value of the sum of the Fourier components in the frequency range df is

$$d\langle I_0^2 \rangle = \frac{2e^2 K}{T} Tdf = 2e^2 Kdf \quad (C12)$$

The average current due to the many events is $I_{av} = Ke$. Thus the final expression for the differential contribution to the mean square of the fluctuating component of the current from the differential frequency interval df is just that given by Equation 18 from which follows Equation 19, the desired formula for the relation between measured quantities and e .

Appendix D: Alternative Shot Noise Explanation - contributed by Seth Dorfman

Consider a photodiode circuit where current is produced by a light source that causes individual electrons to be emitted from the cathode. Each photoelectron will produce a current pulse whose area is the unit of electric charge. Since the total current is a superposition of currents produced by discrete events, the current produced will not be completely constant. The varying component of this current is known as shot noise. It was first cataloged by W. Schottky in a 1918 paper [6].

To derive a quantitative expression that may be used to analyze this phenomena, consider a single current pulse $G_n(t - T_n)$ produced by a single electron striking the anode. The pulse has a narrow width between $t = T_n$ and $t = T_n + \Delta t$. Following Goldman [6], the pulse may be approximated as an impulse and expanded in a Fourier series in the interval from 0 to T :

$$G_n(T - T_n) = \frac{e}{T} + \frac{2e}{T} \sum_{m=1}^{\infty} \cos \frac{2\pi m(t - T_n)}{T} \quad (D1)$$

The first term in the expansion is the DC current for a single electron event; the series term makes up the fluctuating component. The total current from many events

may also be expanded in a Fourier representation. A single frequency component of this sum is made up of a sum of contributions from the $G_{nm} = \frac{2e}{T} \cos \frac{2\pi m(t - T_n)}{T}$ term in each $G_n(t - T_n)$. However, since T_n may be anywhere in the interval from 0 to T , the phases of these components will be randomized. In other words, the components of the total current may be thought of as vectors of the same magnitude, but with all possible phases.

A convenient analogy is unpolarized light passing through a linear polarizer. In that case, the randomized $\cos^2 \phi$ contribution to the intensity averages out such that the final intensity is half of the initial intensity. Similarly, the mean square of the contribution of each G_{nm} to the total current at a given frequency $\frac{m}{T}$ is:

$$\langle G_{nm}^2 \rangle = \left(\frac{2e}{T}\right)^2 \langle \cos^2 \phi_{nm} \rangle = \frac{2e^2}{T^2} \quad (D2)$$

Now, let K equal the number of pulses $G_n(t - T_n)$ per second. The total number of pulses in the interval from 0 to T in any given time is then KT . Thus the sum of $\langle G_{nm}^2 \rangle$ over all pulses n is $\frac{2e^2}{T^2} KT = \frac{2e^2 K}{T}$. This is the mean square of the total current at a given frequency. Since the frequency is given by $F = \frac{m}{T}$, there are $T\Delta F$ frequencies in a given frequency band. Thus the root mean square current within a given frequency interval is given by:

$$I_{RMS}^2 = \frac{2e^2}{T^2} (KT)(T\Delta F) = 2e^2 K\Delta F \quad (D3)$$

Here eK represents the average current. This relation will be explored further in the experiment.