

Lightning and Surge Protection of Photovoltaic Installations

Two Case Histories: Vulcano and Kythnos

François D. Martzloff
National Institute of Standards and Technology

Partial reprint of NISTIR-89 - 4113

Significance

Part 6: Textbooks, tutorials, and reviews

Part 7: Mitigation techniques

Two large installations of photovoltaic (PV) systems located on Mediterranean islands were damaged during lightning storms in 1986-88, even though the manufacturers and installers had provided protection hardware in the form of air terminals dispersed among the arrays, and surge-protective devices in the circuits. The two sites were visited and the damaged equipment that was still available on the site was examined for analysis of the suspected lightning-related damage. The evidence was insufficient to conclude that all the observed damage was caused by the direct effect of lightning. A possible scenario may be that lightning-induced overvoltages in the circuits caused insulation breakdown at the edges of the photovoltaic modules, with subsequent damage done by the dc current generated by the array. Other surge protection considerations were also addressed, and suggestions were presented for further investigations.

This partial reprint includes all the text and circuit diagrams. An extensive collections of photographs recorded on the sites is not included. See the last page of this pdf file for information on possible retrieval of the complete document from the National Technical Information Service.

NISTIR-89 - 4113

Lightning and Surge Protection of Photovoltaic Installations

**Two Case Histories:
Vulcano and Kythnos**

François D. Martzloff

**Electricity Division
Center for Electronics
and Electrical Engineering**

**Prepared for:
Sandia National Laboratories
Albuquerque, NM 87185-5800**

June 1989



**U.S. DEPARTMENT OF COMMERCE
Robert A. Mosbacher, Secretary
NATIONAL INSTITUTE OF STANDARDS
AND TECHNOLOGY
Raymond G. Kammer, Acting Director**

Abstract

Two installations of photovoltaic (PV) systems were damaged during lightning storms. The two sites were visited and the damaged equipment that was still available on the site was examined for analysis of the suspected lightning-related damage. The evidence, however, is insufficient to conclude that all the observed damage was caused by the direct effect of lightning. A possible scenario may be that lightning-induced overvoltages caused insulation breakdown at the edges of the photovoltaic modules, with subsequent damage done by the dc current generated by the array. Other surge protection considerations are also addressed, and suggestions are presented for further investigations.

1. Introduction

Photovoltaic systems are inherently exposed to direct and indirect lightning effects. For high-capacity systems, the deployment of solar cell arrays requires a large area with commensurate exposure to direct lightning strikes at the local annual rate of ground strikes per unit area. The presence of a ground grid related to the PV system in an otherwise isolated area may act as a collector of lightning ground-current from nearby strikes. For PV systems tied to a local power grid, the exposure also includes surges coming from the power grid and the possible differences in the ground potential of the ac power system and that of the dc array system.

In the present development state of photovoltaic systems, occurrences of lightning strikes have been rare, thus field experience is still limited. Nevertheless, justifiable concerns exist, both from the economic point of view of damage versus cost of protection and from the less tangible impact on the perceptions of reliability for a technology still in the early stages of commercial utilization.

The Sandia National Laboratories, sponsored by the U.S. Department of Energy, are developing a Recommended Practice document for the electrical design of photovoltaic systems. As part of that project, the National Institute of Standards and Technology is contributing the lightning, surge protection, and grounding recommendations for these systems, based on known characteristics[†] of surge protective devices and on field experience. By this means, a review of the circumstances and effects of lightning in the few known or suspected cases of lightning damage to worldwide photovoltaic installations will contribute to more effective design and application of future systems.

In this report, two case histories are examined. These include the photovoltaic installations at Vulcano Island (Italy) and at Kythnos Island (Greece). Following the description of these two case studies, a discussion is presented, leading to firm conclusions when the evidence is sufficient, and allowing conjectures when the evidence is less conclusive. Both should serve as an indication of the need for further investigations, laboratory work, or theoretical study.

[†] Certain commercial devices are identified in this report in order to describe adequately the installation and expected performance of the system. Such identification does not imply recommendation or endorsement by the National Institute of Standards and Technology, nor does it imply that these devices are necessarily the best available for the purpose.

2. Surge Protection at the Vulcano Island Installation

2.1 Background

Vulcano is one of the islands in the Aeolian Group in the Tyrrhenian Sea, north of Sicily. The photovoltaic system in this island was designed by ENEL, the Italian national electric utility, as a research and demonstration facility and was commissioned in 1984 (Photograph 2-1).^{*} ENEL has been operating this facility since the commissioning. The visit, arranged by Dr. A. Previ of ENEL, took place in November 1988.

One case of damage attributed to lightning has been reported, with damage to only one panel (Photograph 2-2). No other damage occurred in the system, not even to the protective varistors provided at each junction box in the array

field. This history makes that site an interesting case study, considering the scarcity of documented lightning occurrences on photovoltaic systems.

2.2 System Configuration

The Vulcano photovoltaic system (see Figure 2-1) includes the following major components: the array (1); a storage battery (2); one self-commutated, stand-alone inverter (3); one line-commutated inverter (4); a rectifier for charging the battery (5); and a static switch (6). More complete system diagrams by ENEL are given in Appendix A [1].

Photograph 2-3 shows the block diagram of the system provided on the control cubicle. Interface with the 20 kV ac grid of the island is obtained by the three-winding 150/150/20 000 V transformer which is an integral part of the

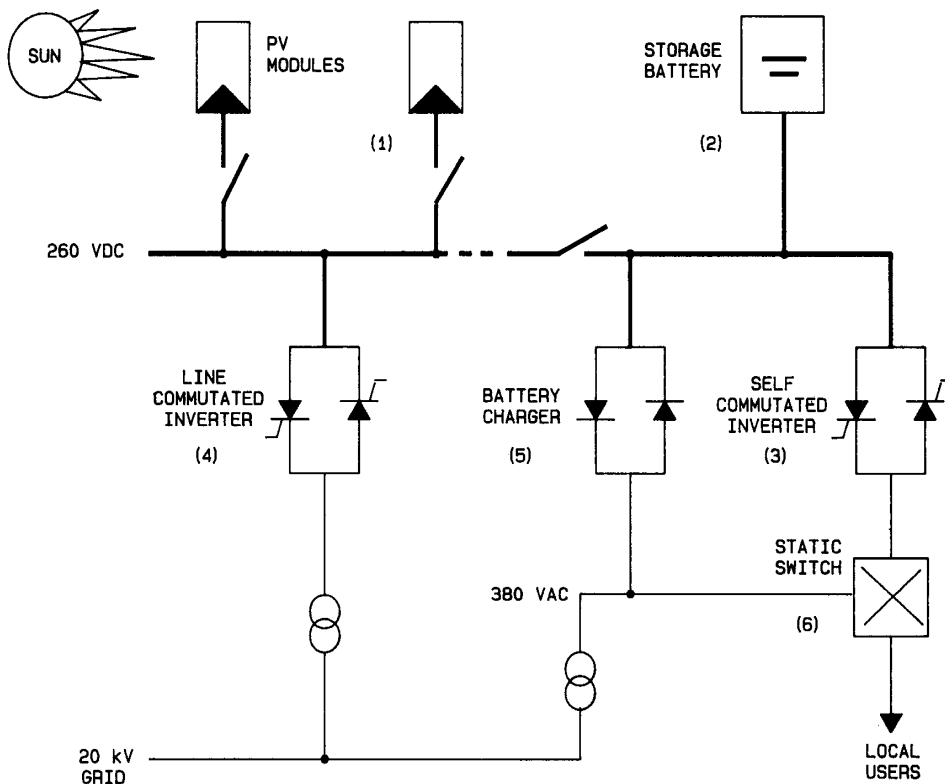

Figure 2-1. Block diagram of the Vulcano photovoltaic system

^{*} Photographs cited in this text are included in Appendix D, starting on page 37.

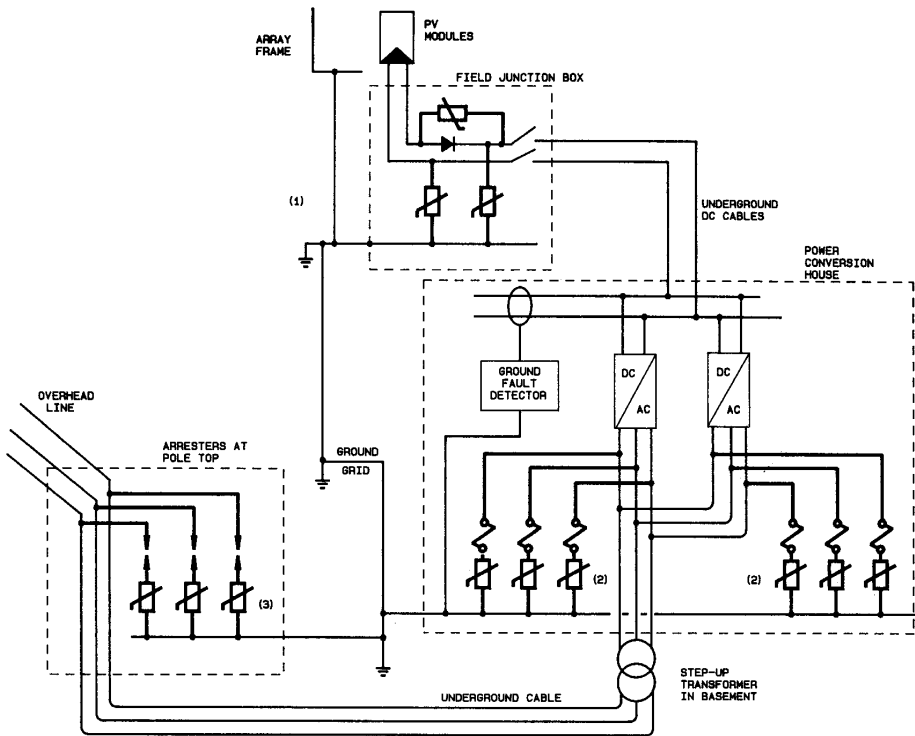

Figure 2-2. Surge protective devices at system interfaces

output circuit of the line-commutated inverter. A group of 40 local domestic users was originally supplied at 380 V by an existing substation connected to the 20 kV grid. The 380 V bus of the substation was modified to allow power flow from the output of the stand-alone inverter, through the static switch, to the local users.

With this configuration, the system can operate in two modes: grid-connected, and stand-alone. In the grid-connected mode, the tie to the grid is obtained through the 150/150/20 000 V transformer, absorbing all of the plant output. In that mode, the storage battery is not in the circuit, and the local loads are supplied by the ac grid. In the stand-alone mode, the local loads are supplied at 380 V directly from the self-commutated inverter. In that mode, the storage battery is connected to the dc bus and it can either absorb power from the array or deliver power to the inverter. The local loads can also be supplied, if necessary, from the island ac grid through a back-up transformer.

Individual strings from the array can be switched by dc contactors located in the control room, to be connected to the dc bus or discon-

nected from the dc bus according to the charge state of the battery. For maintenance purposes, a dc disconnect is located in terminal boxes next to the respective strings of the array (Photograph 2-4). Mechanical interlock is provided between the contactor and the cover of the terminal box, which prevents accidental opening of the disconnect under load.

2.3 Grounding Practices

A major design decision in a photovoltaic system is whether to ground or not to ground the dc side. In contrast to ac power systems, which are grounded in most cases (by generally accepted practice or by mandate, depending on the country), no general agreement has been reached on grounding practices for photovoltaic systems. Two reasons are generally cited for an ungrounded system:

- (1) the possibility to continue operating with one ground fault on the system, and
- (2) some limitation of single L-G fault currents and hence reduction of damage in case of a fault, because two ground faults are then required to produce a significant dc fault current.

In the Vulcano system, the dc system is not grounded. A ground fault detection system is provided (Figure 2-2), with alarm indication on the control panel (Photograph 2-3) but no automatic trip nor remote indication of the fault condition (the system is unattended). Experience with this system is described as satisfactory after an initial period of reported difficulties associated with insulation deficiencies in the panels. (These were eventually corrected by field or factory rework on the panels.)

While the dc system is not grounded, a ground grid has been installed at the site, for safety, surge protection, and grounding of the ac side. In addition to a grid of ground cables running along the dc cables in the array (but outside of the plastic conduits containing the dc cables, see Photograph 2-5), ground rods (16 rods, each 2 m long) were driven into the earth. Considerable care was given to the implementation of this ground grid. For instance, the integrity and effectiveness of the grounding system for protection against step voltage and touch voltage, in case of a ground fault on the 20 kV system, were the subject of well-documented tests. Providing low impedance earthing was made easier by the volcanic nature of the soil, which resulted in the unusually low value of 1.8 Ω for the earth resistance. The lower leg of each panel frame is bonded to the ground grid (Photographs 2-6 and 2-7).

Concerns frequently associated with grounding practices are corrosion of connections and leakage of the insulation from energized parts to ground. At this site, the ground grid was implemented with direct-burial copper cables with welded connections (Photographs 2-5 and 2-7), an effective assurance against corrosion problems. Some corrosion problems occurred in the original metal boxes containing the module by-pass diodes (Photograph 2-8). The problems were corrected by improving the insulation to ground with a better sealing of the metallic frames.

The significance of a history of corrosion/ insulation tracking is that these insulation problems may be a clue to a scenario other than that of simple direct lightning damage. One may speculate on a scenario involving a double ground fault that could have resulted in panel damage; this scenario will be presented in the discussion of the observations of Section 2.5.

2.4 Surge Protection

Overvoltage protection for the Vulcano system is provided at three interfaces, as sketched in Figure 2-2:

(1) At the terminal box of each pair of strings (Photograph 2-9), between each of the two dc lines and ground, by one 32-mm diameter varistor (4 total) rated 560 V dc (GE Cat. No. V420HE400). No further protective devices are provided at the entrance of the dc cables to the power conditioner house (the capacitor bank at the input of the inverters can serve as overvoltage limiter for any impinging surge because the front time is relatively long as a result of the cable impedance). The blocking diode for each string, located in the field terminal box, is protected by one 32-mm diameter varistor (2 total), rated 560 V dc (GE Cat. No. V420HE400). This varistor has a clamping voltage of 1200 V for a 300 A peak surge current. The repetitive peak voltage rating of the diode (IR Cat. No. SD 70N12P) is 1200 V.

(2) At the 380 V ac interface of the output of the inverters, by three varistors connected line-to-ground (Photographs 2-10 and 2-11). These are also 32-mm diameter varistors, with a 420 V ac rms rating (GE Cat. No. V420HE400). A fuse rated 8 A, 500 V, 100 kA interrupting capacity is provided in series with each varistor (Photograph 2-12). About 50 cm of leads are used to connect the varistors to the 380 V terminals at the base of each inverter cabinet. (In this case, this length is not significant because of the front time limitation discussed above.)

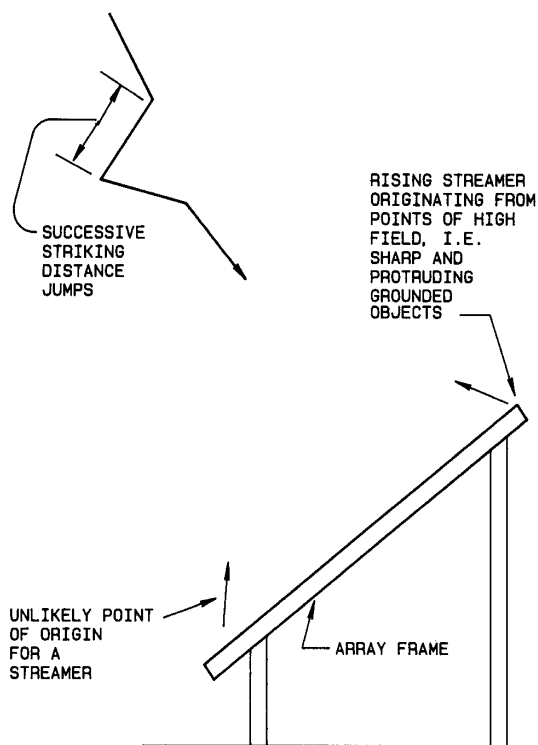

Figure 2-3. Descending stepped leader and rising streamer in a cloud-to-ground lightning strike

(3) At the 20 kV interface with the island system, by “conventional” surge arresters installed at the potheads of the underground connection, and connected line to ground (Photograph 2-13). The 20 kV overhead line stops about 200 m from the control room, with the final connection to the plant made by underground cable (Photograph 2-14).

2.5 Discussion

2.5.1 Lightning damage report

The damage caused to the PV panel by the presumed lightning strike is shown in Photograph 2-2. (The photograph was supplied by Previ as part of the background history; the damaged module was not available for examination.) This damage occurred during the commissioning period of the plant in the autumn of 1984; it was found early in the morning by the ENEL staff after a thunderstorm occurred during the

night. The glass and part of the cells were described as “melted near the metallic frame of the module.” No failure of the blocking diode nor of the varistor of that string was found as a result of that incident.

2.5.2 Lightning damage scenarios

The damage to the module is located at the lower part of the array, as shown in Photograph 2-2. Postulating a scenario of a direct strike to the array, the point of attachment of the lightning would be the point of origin of the rising streamer that meets the descending stepped leader (Figure 2-3).

This position at the lower part of the array is rather unexpected for the point of initiation of the streamer. A more likely point for streamer initiation – and resulting termination of the strike – would be the upper edge of the array, which is 2 m above grade level (Photograph 2-15). Thus, there is some doubt on drawing a conclusion that the damage was the result of a direct strike terminating at the array.

In view of the reported insulation problems that occurred during the initial period of operation, one might ask whether the damage to that panel might be the result of a leakage of dc current to the frame, rather than the simple direct effect of a lightning strike. This dc leakage might be the consequence of a lightning induced overvoltage stress that created a double fault in one single event, or that created the second fault after the first had previously occurred but remained uncorrected. The scenario could unfold as follows:

Assume that two independent ground faults, (A) and (B) have occurred on the system (Figure 2-4). When the first, say (A), occurs, the fault detection system indicates that event but no immediate action is taken because of the unattended status of the system, and there is no ground fault current resulting from that first fault (except the insignificant current passing

through the detection circuit). A ground fault current can exist only after the second fault occurs, establishing the path through (A) and (B).

Assume now that one of the two faults, say (B), involves a very low resistance. Then, even for substantial fault currents, little heat is generated at fault (B). Assume further that (A) has a low enough resistance to produce a “sufficient” current in the fault path, where “sufficient” is defined as a level which, combined with the low but finite resistance of fault (A), will create heat dissipation in (A), in contrast with the negligible heat dissipation in (B).

In this manner, we have the elements that could create the observed effects, that is, an obvious fault with burning at (A), and a less obvious fault at (B), with a low resistance that may be eliminated during emergency maintenance work following the occurrence of the incident. The likelihood of such a double fault is admittedly low, but cannot be ruled out in view of the design of the ground fault detection system which indicates faults locally only. This scenario, still associated with lightning, would not be in contradiction with the observed low position of the damage since it does not require termination of the strike at that low point of the panel. Furthermore, the low point on the sloped array is also a place where moisture is more likely to accumulate and thus create a good candidate for a contributing cause in the scenario of two-stage insulation breakdown.

A variation on the theme of the double fault might even be that the fault was entirely caused by long-term insulation breakdown, without the “*coup de grace*” administered by the lightning incident. However, the observation of a damaged module soon after a lightning storm would point to the lightning-induced overvoltage scenario.

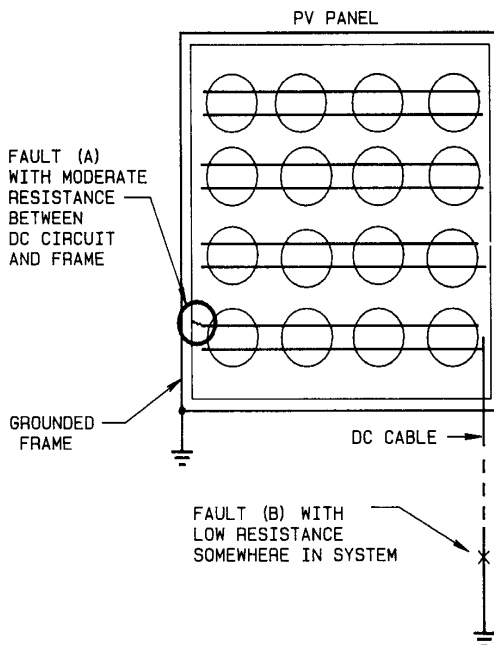

Figure 2-4. Scenario of double ground fault

One significant aspect of the failure mode is the reported shattering of the glass cover of that module. The question is whether it could have been produced by the less violent action of a dc fault (glass breakage has been reported in the United States during dc ground faults), or could be explained only by the mechanical shock associated with a lightning strike. The reported melting of the glass is also a clue that could be investigated further.

If data were available on the failure modes of this type of module, some of the conjectures proposed in this discussion might be replaced by more positive conclusions. The incentive for reaching such positive conclusions is not merely one of intellectual curiosity. If overvoltages induced by indirect lightning are sufficient to cause insulation breakdown, then the provision of lightning air terminals is irrelevant – and thus becomes an unjustifiable cost – while improving the insulation levels in the modules would yield better results for the added expense.

2.5.3 Insulation coordination

Coordination of the protective devices with the withstand capability of the equipment to be protected is sometimes overlooked in system designs. At the Vulcano site, this coordination was presumed to have been incorporated in all the system design and was not audited during a visit aimed primarily at a review of the lightning incident.

However, given the concerns on the protection afforded by the varistors, the coordination for one example of protection can be evaluated by a simple comparison: From their catalog description, the blocking diodes of the array strings have a repetitive peak voltage rating of 1200 V (albeit not a perfect assessment of their transient withstand capability). Therefore, the maximum clamping voltage for the protective varistor should not exceed 1200 V. For a varistor rated 560 V dc, this maximum allowable clamping voltage of 1200 V corresponds to a 300 A surge crest current. In other words, protection can be expected as long as surge currents do not exceed 300 A in that string.

At first glance, this 300 A allowable level of surge current may appear low. However, when postulating a lightning-induced surge current level in the wiring, one should not be influenced by the thousands of amperes of the direct stroke, but rather consider the voltage required to drive the postulated current waveform along the inductance of the wiring: a high rate of current change means a high driving voltage. However, in this case, high driving voltage would not be possible because sparkover of the insulation would occur. Thus, the 300 A crest of an 8/20 μ s postulated waveform appears an appropriate order of magnitude. In this example, therefore, insulation coordination was in fact achieved for voltage levels that might be induced in the wiring.

2.6 Suggestions on the Design

In his role of sponsor of the visit, Previ asked for comments on the surge protection provided at this site. Accepting for the moment the hypothesis that lightning was the cause for damage to the panel, the successful operation of the installation and survival of the electronics through one lightning occurrence are already a testimonial of the adequacy of the protection system.

Taking a devil's advocate view in search of greater protection, a more conservative approach could have been to provide additional surge protection for the incoming dc cables at the interface with the inverter inputs, but experience so far has indicated survival without these additional protective devices. This observation, however, does not necessarily guarantee that another lightning strike scenario, with a different point of termination or higher amplitude, could not induce some damaging overvoltage along the cables between the array protections and the inverter input.

A concern expressed by Previ was the failure mode of the varistors installed at the base of the electronic cabinets at the ac interface. These varistors can be expected, in case of failure, to be promptly isolated from the power source by operation of their series-connected fuses (that have ample interrupting capacity). Therefore, the generation of hot gases during the short-circuit following failure of the varistor would be brief. Again, as an exercise in very conservative design, a further step could be applied to limit the consequences of a varistor failure by providing a partial metal shielding around the varistors to deflect any evolving gas away from the rest of the circuit. The 8 A rating of the fuses seems adequate to avoid premature aging of the fuses caused by repetitive surges [3], should such repetitive surges occur at that site.

Previ also asked about the possibility of monitoring the condition of the varistor aging for the purpose of anticipating an impending failure. This question has been raised by many users, sensitized to the issue by competitive claims from advocates of silicon avalanche diodes. At this time, no easy method has been proposed for field measurements (especially in dc circuits where a clamp-on transformer is not suitable [4]).

Increasing concerns on the issue are likely to catalyze the development of such measurements. For the moment, the only technically simple but operationally difficult method would be to remove each varistor from the circuit and compare its present nominal voltage to its original nominal voltage. In existing installations, that information is not likely to be available. An intermediate solution for this installation would be to implement monitoring the varistors, albeit at a late stage of the project, and watch for trends, even though the initial value is not available. As a last resort, a surface temperature measurement on the varistor might give a warning of impending failure.

This discussion of varistor failure scenarios should not be interpreted as an inference that the varistors are in fact in jeopardy. It is only

an exercise in asking and answering conservative "what-if" questions.

2.7 Specific Conclusions from the Vulcano Case

The experience accumulated at the Vulcano site indicates no major problem of surge occurrences, with only one reported case of damage to one panel among several hundred. This one case of damage is not conclusively attributable to lightning.

Furthermore, even if the damage were caused by lightning, then a partially satisfactory conclusion would be that sufficient protection could be provided for the electronic components in the power conditioning system, at least for that particular case. Power conditioning equipment is the most expensive part of the system and cannot be considered "expendable" in contrast with a few modules being lost with the rest of the system remaining operational. The ambiguity in attributing the damage to direct or indirect lightning might be resolved by further study of the failure modes of a panel (a module within its frame). One failure mode to be investigated would be under simulated lightning strikes; the other failure mode would be under dc stress with surface contamination. Further discussion of this issue, from the technical as well as economic and intangible aspects, is offered in the general discussion of Section 5.

3. Surge Protection at the Kythnos Island Installation

3.1 Background

Kythnos is one of the islands in the Cyclades Group, in the southern part of the Aegean Sea. The photovoltaic system on this island was designed and implemented in 1983 by Siemens. It is operated by the Greek Public Power Corporation. The visit, which was arranged by Dr. J. Chadjivassiliadis of Public Power Corporation, took place in November 1988.

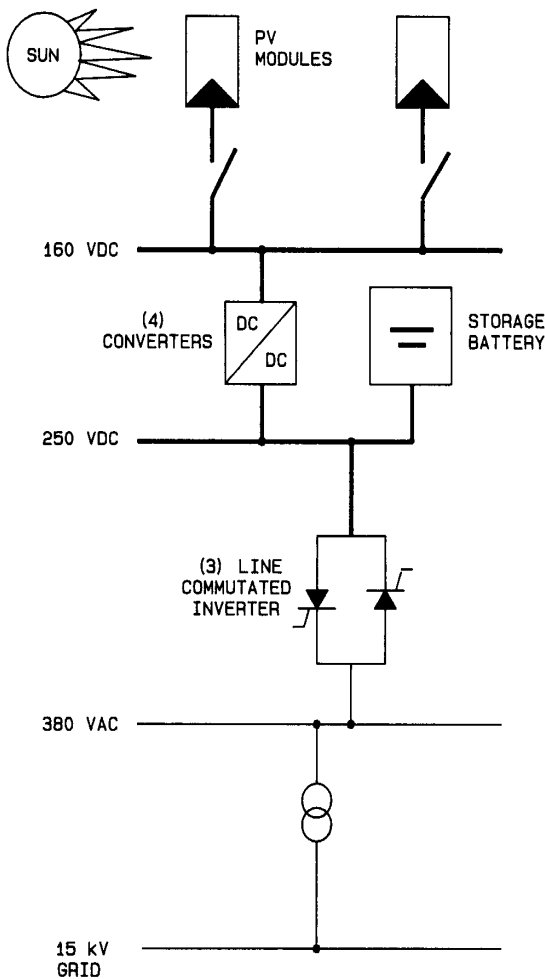

Figure 3-1. Block diagram of the Kythnos photovoltaic system

Several panel failures have occurred in 1986, 1987, and 1988, which have been attributed to lightning. Lightning rods and surge arresters are provided at this site, making it an interesting subject of study, both for an explanation of the presumed direct strikes occurring in spite of the lightning rods, and for a study of the protection afforded by the surge protective devices installed in the circuits, as well as their failure modes. Further information on the history of panel damage is included in Appendix B.

3.2 System Configuration

The installation was designed and implemented by Siemens, as one of the experimental facilities coordinated by the European Economic Community (Photograph 3-1). The plant has a nominal output capacity of 100 kW. Figure 3-1 shows a schematic of the system components. The modules are grouped in arrays formed by a series string of 20 modules, each producing a dc bus voltage of 160 V. Each of these 43 arrays is terminated in a junction box in the field, where two or three strings are connected in parallel to bring the dc power to the power conversion cabin (Photograph 3-2).

In the power conversion circuitry, the variable 160 V dc is raised and regulated to 250 V by a dc/dc converter to match the battery voltage for optimum charging conditions and operation of the solar cells. The dc/dc conversion is performed by four units, each rated 25 kW. Depending on the instantaneous power transfer, one to four converters are in service.

Conversion to ac power is performed by three inverters, each rated 50 kW. The output voltage of 380 V is stepped up to 15 kV for connection to the island power grid. Although the arrays and conversion equipment are located adjacent to the Diesel generating plant of the island, operation of the photovoltaic system can be

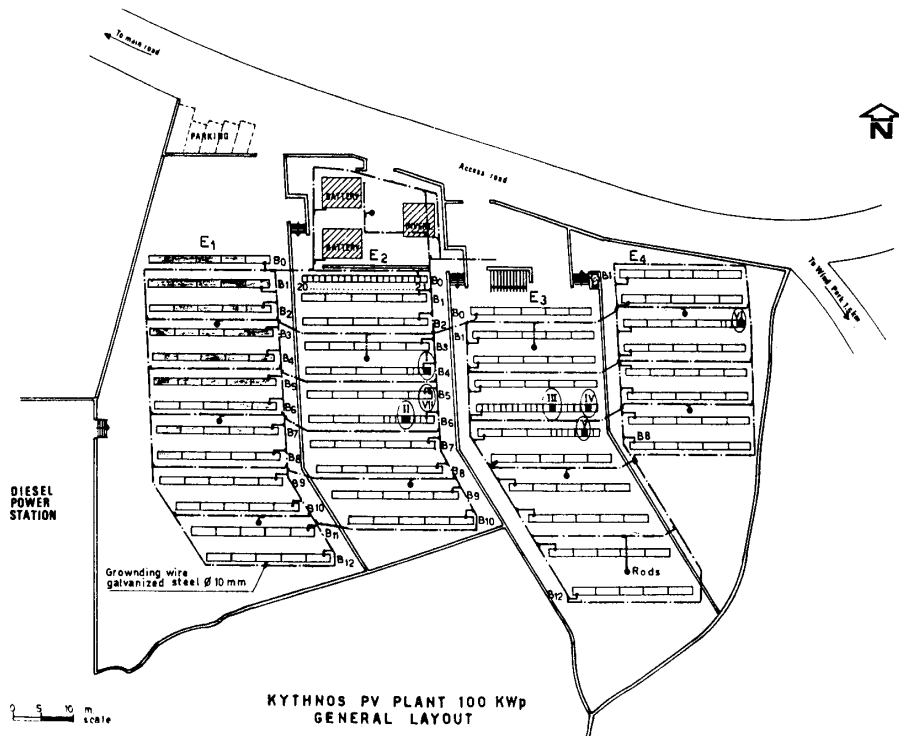

Figure 3-2. Location of ground cables, air terminals, and modules presumed damaged by lightning

Source: Kythnos records (Appendix B)

automatic, and does not require daily supervisory. Extensive monitoring and control of operating parameters is provided by a "Logistronic" control system and other controls incorporated in the design.

3.3 Grounding Practices

This site is located in the center part of the island next to the Diesel power plant, but with its ground grid isolated from that of the Diesel plant. This grid consists of several loops encircling each of the four groups of arrays. Part of the each loop follows the routing of the dc cables between the array junction boxes and the power conditioning cabin (Figure 3-2).

The perimeter of the field is defined by stone walls, in keeping with the prevailing island practice for marking boundaries between pastures and cultivated fields. Consequently, there is no metal fence around the photovoltaic field, and thus no perimeter grounding cable. The conductors are made of 10-mm diameter galva-

nized steel, buried directly at the bottom of a trench, with the dc cables above the ground conductors. There are no driven ground rods added to this grid. The choice of galvanized steel probably reflects the German practice, where concerns over corrosion effects by buried copper seem to deprecate the use of copper.

All the metal structures of the system, including the array supporting beams, junction boxes, lightning rods, and housings for the power conditioners and battery, are bonded to the ground grid. Connections are made using bolted connectors above ground (Photographs 3-3, 3-4, and 3-5), as well as under ground, with protection against corrosion being provided in accordance with the normal practices of the various manufacturers and contractors (these were not discussed during the visit).

The dc system is not grounded, but includes a ground fault detection circuit with fault indication available only in the control cubicle of the system. The separation of the photovoltaic ground grid from the Diesel plant ground grid

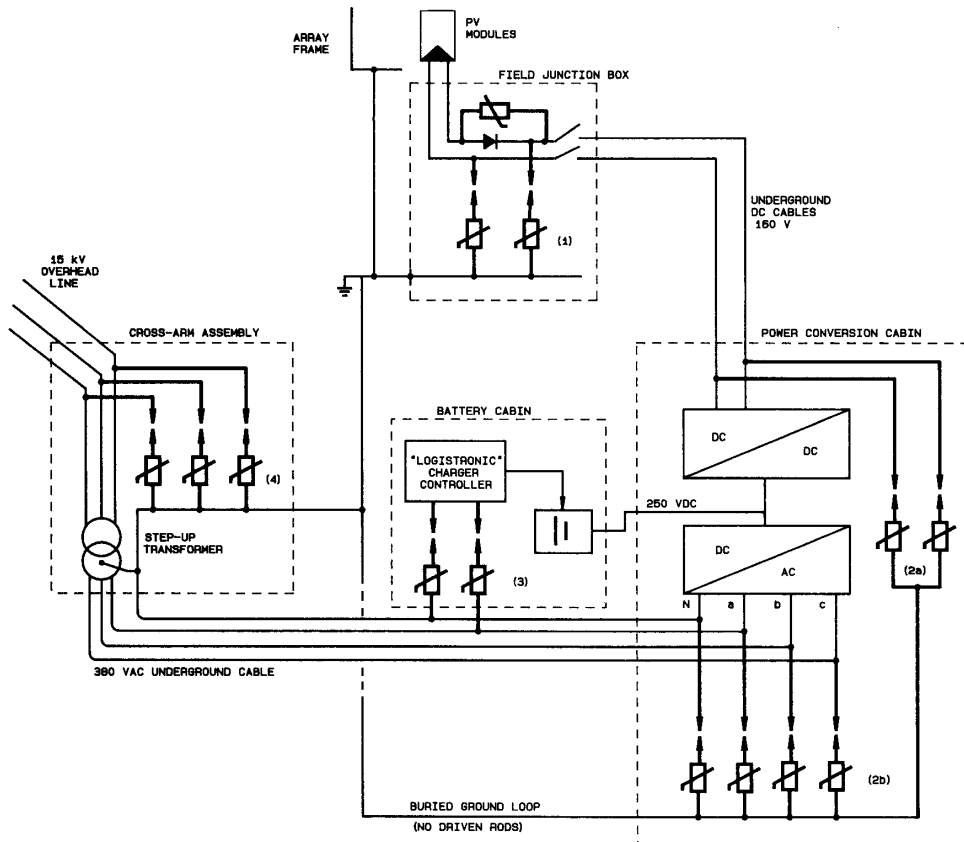

Figure 3-3. Overvoltage protection at system interfaces

raises the question of a possible difference of ground potential between these two systems during a lightning strike. If instrumentation or telemetering equipment spans across the two systems, the difference in ground potentials might become a problem. However, no such problem was identified at that site.

3.4 Surge Protection

This installation presents an interesting case history because it includes both lightning rods (air terminals) in the array and surge arresters in the circuits. Damage to several panels, presumably as a result of lightning over a period involving three separate occurrences, raises questions on the effectiveness of the protection against direct strikes. Damage to the surge arresters also occurred in one of the field junction boxes, but no damage occurred on the power conversion units. Some damage occurred in the control circuits of the battery charger during the initial period, when they did

not have surge arresters at their ac power input. After arresters were added to this ac input, no further damage events occurred but some upsets did still occur in the control system.

3.4.1 Air terminals

Air terminals (lightning rods) have been installed between rows of the array as shown on Photograph 3-6. The height of these air terminals is 10.5 m above grade level; the upper edge of the panels is 2 m above grade level, thus leaving a net elevation of the air terminals 8.5 m above the upper edges of the panels. Considering a 45° cone of protection, one of the classical criteria, the panel upper edges would then be "protected" within a radius of 8.5 m from each air terminal. Those panels located beyond that radius would be left unprotected. Reviewing the location of panels involved in the damage (Figure 3-2) shows the following horizontal distance from the nearest air terminal:

- Module E2/B4/1	- Location	10m
- Module E2/B6/5	- Location II	10m
- Module E3/B4/13	- Location III	10m
- Module E3/B4/19	- Location IV	12m
- Module E3/B5/18	- Location V	8m
- Module E4/B3/20	- Location VI	10m

Thus, five of the six damaged modules were beyond the 45° cone, and the sixth was on the fringe of the cone. Some panels in the array, not impacted by lightning, are further away from an air terminal, the greatest distance in the field being 15 meters. Another interesting statistic is the distribution of the panels with respect to being within a protected area of 8.5 meters radius (approximately 75%) or outside the protected area (25%).

Another protection criterion has been developed, that of the "rolling ball" [5], as discussed in section 3.5. According to that criterion, the protection radius would extend to 12 m so that all panels would have been expected to be in the protected zone.

According to yet another definition of the cone of protection, sometimes cited by less conservative designers, a 2:1 instead of a 1:1 ratio of radius to height may be considered. In such a case, one would expect all of the panels to be "protected" as the distance from the mast would increase to 17 m.

It is not known whether such a 2:1 cone, or the 1:1 (45°) cone, or the rolling ball with a 30-m radius was used in the initial layout of the air terminals. The design has been described as "installed according to VDE standards" (VDE is the acronym for Verein Deutscher Elektrotechniker) (see Appendix B).

3.4.2 Overvoltage protection

Overvoltage protection at the Kythnos installation is provided at four interfaces, numbered (1) through (4) in Figure 3-3:

(1) At the junction boxes in field - There are several slightly different types of junction boxes in the field. Some include termination for two or for three strings, while some also contain additional circuitry for the data collection system. Photograph 3-7 shows a typical three-circuit box (undamaged). One surge arrester is connected between each of the floating dc lines (+) and (-) and a ground bus inside the box. In turn, this bus is bonded to the footing by a copper cable (in parallel with the inherent bonding between the metallic junction box and the I beam of the footing).

These arresters appear similar to those for which the voltage response had been documented in a paper presented at the 1981 EMC Zürich Symposium (Appendix C). From the voltage response characteristic reported in that paper, it appears that the surge arrester consisted of a silicon-carbide varistor with a series gap. The presence of a series gap is significant in discussing the upset events cited for the control circuits at this site.

The string blocking diodes are mounted in the junction box and are protected by a metal-oxide varistor connected in parallel with each diode (Photograph 3-8). Photograph 3-9 shows another junction box with the additional data collection circuitry installed in the box cover. This particular box is the one where the lightning-suspected damage occurred, as shown in the close-up views of Photographs 3-10 and 3-11.

(2) At the power conversion units - The dc lines from the array are brought to the cabinets of the dc-dc converters where each of the four converter inputs is protected by two surge arresters (2a) (Photograph 3-12) connected between the (+) and (-) lines, and ground. This arrester is of the same type as that described for the array junction boxes.

Similarly, the ac outputs of the inverters are protected against surges from the ac grid by four arresters (2b); one is connected between each line (a,b,c) and ground, and one between neutral and ground (N) (Photograph 3-13). While the grounding connection of the 220/380 V system was not reviewed, presumably it follows the European practice of bonding to earth only at the secondary transformer, in this case the step-up transformer of the grid interface. This practice, different from that used in the United States, motivates and justifies the provision of the arrester between neutral and ground.

(3) At the Logistronic circuit power supply - The "Logistronic" circuit controlling the battery charger is powered from the 220 V ac line in the battery cabin. Thus, its power supply is exposed to surges that may occur on that supply. Initially, there was no protection on this ac supply; perhaps as a consequence, damage occurred three times in the early years of the system (Appendix B). Subsequently, two arresters were installed on the ac supply line ahead of the Logistronic input terminals (Photograph 3-14). After these ac arresters were installed, only upsets were recorded (four occurrences). This behavior is consistent with the voltage-limiting effect of the arresters but at the price of a steep voltage collapse when the gaps fire (Appendix C). This electromagnetic disturbance is a likely source of interference in nearby digital circuits.

(4) At the ac grid interface - Protection against surges coming from the island ac power grid is provided by the three distribution-type arresters mounted on a cross-arm above the transformer (Photograph 3-15). No information was available on these arresters; they are likely to be of the conventional design using a silicon carbide varistor with a series gap.

This type of arrester is perfectly adequate for protecting transformers against surges, but might not be sufficient for the electronic components on the 220/380 V side. For that reason, the secondary arresters described above are a good idea. However, gapless secondary arresters are now available that can offer a more comprehensive protection, including some degree of upset protection.

3.4.3 Examination of the damaged modules

3.4.3.1 Summary

At the date of the visit, the three modules damaged in 1986 had been replaced in the array. These modules were still kept in storage at the site, so that it was possible to examine them closely. The two modules damaged in 1987 and the one module damaged in 1988, however, were still in position in the array, as no spares were available. Detailed photographs and observations for each panel are given in the following paragraphs, in chronological order.

At this site, the arrays are only one module high, so that the long edge of the module reaches from the highest to the lowest edge of the array. In all six failed modules, there is damage evident at one or both upper corners, along one or both long edges, and at the bottom of the module. The panel is completely separated from the frame in some cases, while in other cases, only partial separation occurred. One of the modules has severe burn marks on the top corner of the frame, while on the other modules the damage ranges from none to some readily visible burn marks.

3.4.3.2 Detailed examinations

MODULE - 307 0423 This module was in storage and had been at location E2 B4 1 ("I" on Figure 3-2), 10 m from the nearest air terminal. There are burn marks along both long edges,

but not the complete length (Photograph 3-16). On the right side, the burns are mostly at the lower part of the edge, away from the most damaged corner (Photograph 3-17). On the left side, the burns are mostly in the upper part, with intriguing spots over some of the cells (Photograph 3-18). The top right corner shows some marks on the frame, with the most extensive damage at that corner (Photograph 3-19).

MODULE - 303 0267 This module was in storage and had been at location E3 B5 18 ("V" on Figure 3-2), 8 m from the nearest air terminal. There are burn marks along both vertical edges, but not over the complete length (Photograph 3-20). On the right side, the burns are mostly at the upper part of the module, with damage at both corners (Photographs 3-21 and 3-22). The top right corner (Photograph 3-21) shows heavy burn marks on the frame, while the top left corner (Photograph 3-23) shows light marks on the frame. It should be noted that this module, which has the heaviest burn marks on its frame among the six modules, is the only module that was located within the "cone of protection" of an air terminal. This remark will be discussed further in the next section.

MODULE - 304 0294 This module was in storage and had been at location E3 B5 19 ("IV" on Figure 3-2), 12 m from the nearest air terminal. There are burn marks along all of the right side, and part of the left side (Photograph 3-24). Both top corners show damage (Photographs 3-25 and 3-26). The top right corner (Photograph 3-25) shows light burn marks on the frame, while the top left corner (Photograph 3-26) hardly shows any burn marks on the frame. There is extensive separation of the panel from the frame along the right side (Photograph 3-27)

MODULE - 306 0417 This module is still in the array at location E2 B6 5 ("II" on Figure 3-2),

10 m from the nearest air terminal, and was found damaged on February 5, 1987. The bypass diode in the string allows the array to remain operational. The right edge shows burns (Photograph 3-28). Both right side corners show extensive destruction of panel material (Photographs 3-29 and 3-30), but the upper corner has no burn marks on the frame (Photograph 3-29).

MODULE - 304 0300 This module is still in the array at location E3 B4 13 ("III" on Figure 3-2), 10 m from the nearest air terminal, and was found damaged on February 5, 1987. The bypass diode in the string allows the array to remain operational. There is damage on three of the corners and some of the edges (Photographs 3-31, 3-32, and 3-33), but the heaviest damage is on the lower left corner (Photograph 3-34). The two upper corners shows surface degradation on the frame, but these do not appear to be burn marks (Photographs 3-32 and 3-33).

MODULE - 310 0592 This module is still in the array at location E4 B3 20 ("VI" on Figure 3-2), 10 m from the nearest air terminal, and was found damaged on February 25, 1988. The bypass diode in the string allows the array to remain operational. The damage is concentrated on the left edge of the module (Photographs 3-35 and 3-37). The panel is separated from the frame (Photograph 3-38). The apparent discoloration of the frame at the top left corner does not seem attributable to burns (Photograph 3-36).

3.5 Discussion

3.5.1 Effectiveness of air terminals

Lightning protection of solar arrays by air terminals is still a subject of debate (effectiveness, shadow effects, cost, appearance). The observations made at the Kythnos site do not bring

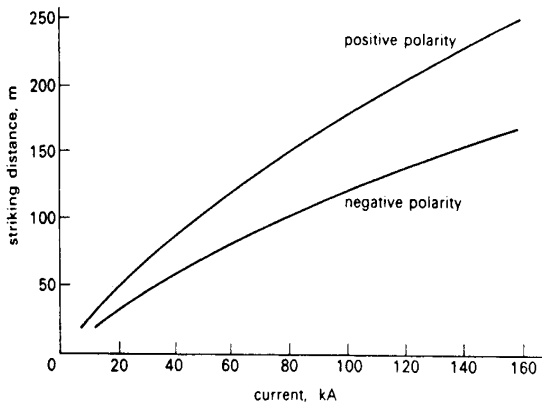

Figure 3-4. Relationship between potential current level of return stroke and striking distance
(Source: Reference [6])

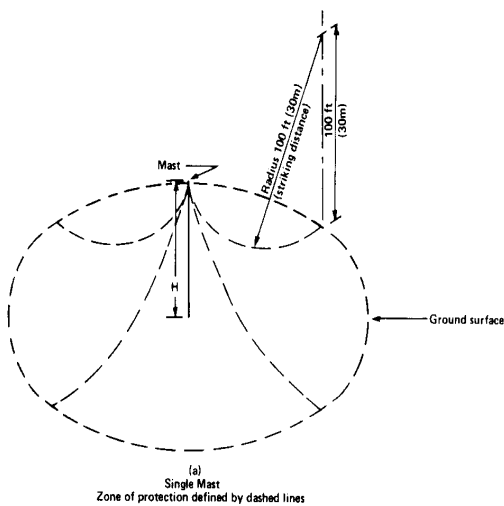

Figure 3-5. Rolling ball criterion
(Source: Reference [5])

conclusive evidence for or against the effectiveness of correctly designed air terminals, although they tend to weaken the case for providing air terminals.

The Kythnos experience involves points of (presumed) lightning termination that are at the edges of the zone of protection of several criteria, where this protection becomes more uncertain. Ironically, the most severe burn mark is found on the frame of the module that was

closest to an air terminal, and within the zone of protection as detailed in paragraph 3.4.1. Thus, a brief review of the uncertainties of the zone-of-protection concepts will provide the necessary perspective on the issue.

Indiscriminate application of the 45° cone of protection criterion to tall structures has led to contradictions. An example is occurrence of lightning strikes terminating on the side of tall buildings, within the cone of “protection”. The original concept of a cone of protection is now generally replaced by the rolling ball criterion, based on the striking distance theory. According to this striking distance theory [6], the striking distance at the tip of the descending stepped leader increases with the amount of charge in the leader. Thus, the leaders having the highest potential current level have the longest striking distance (Figure 3-4). Conversely, leaders having the lowest potential current level have the shortest striking distance. The point of termination of a lightning strike can be anywhere within the striking distance from the last point of advance of the descending stepped leader. This fact can be represented by imagining a sphere with a radius equal to the striking distance, which is determined by the charge in the lower part of the leader. Any point at ground potential penetrating that sphere is a candidate for emitting an upward streamer that will complete the path for the return stroke. Thus, points at ground potential outside of the sphere are still “protected” while the points inside the sphere are not.

Considering now the configuration of a vertical mast on the ground plane (Figure 3-5), rolling a ball on the ground until it touches the tip of the mast defines the limiting condition when the descending leader will terminate at the tip of the mast, thus leaving other points below the sphere uninvolved. Figure 3-6 shows

graphically the configuration for the 10.5 m masts used in Kythnos, with the upper edge of the panels at 2 m above the ground plane.

Figure 3-6 shows the zone of protection as defined by the traditional 45° cone of protection, as well as that defined by a rolling ball of 30 m radius, as specified in the Lightning Protection Code [5]. Simple geometry shows a distance of 8.5 m from the mast for the 45° cone, while the graphical solution for the rolling ball shows a distance of 12 m from the mast. It should be emphasized that the selection of a 30 m radius for the ball is somewhat arbitrary, in view of the data shown in Figure 3-4. From Figure 3-6, it is apparent that a pessimistic assumption would be a smaller radius for the rolling ball: such a smaller ball would roll closer to the mast and thus would reduce the “protected” distance from the mast.

This observation needs to be combined with the statistical distribution of lightning current amplitudes as stated by Cianos & Pierce [2] to appreciate that the 30 m radius is only a pragmatic

choice, not an absolute criterion. Therefore, observing points of presumed lightning termination at distances of 8.5 m to 12 m from the base of an air terminal is not startling, especially for low-current strokes. This observation shows how precarious the assurance of protection can be when only sparsely distributed air terminals are provided. In other words, increasing the degree of confidence that sufficient protection zones are established might require such a density of masts (or overhead wires) that the cost, appearance, and shadow effects would loom large in the overall trade-off.

3.5.2 Lightning current path

The resulting return stroke would then draw charges from the earth via the grounded structure, that is, the return current would come out of the grounding cable at the base of the column, and proceed by the shortest route toward the upper edge of the panel. This shortest path does not include the lower half of the panel

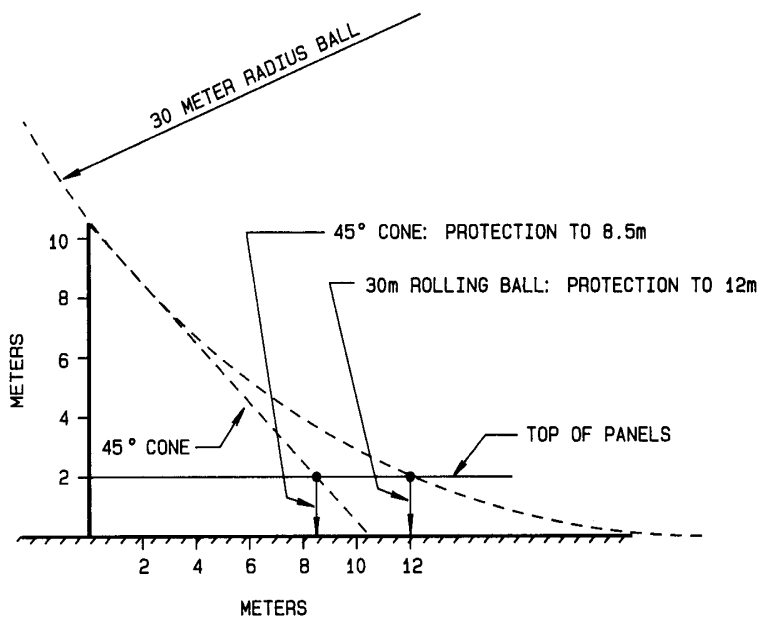

Figure 3-6. Cone-of-protection and rolling-ball criteria

edges, as it would require the lower panel brace plus the panel edge to become involved. While this path may still be somewhat involved, the major part of the current should only involve the upper half of the panel, a situation which is not reflected in the more or less even (or random) distribution of the damage observed on both upper and lower halves of the long edges of the modules.

3.5.3 Direct versus consequential effects

In the absence of definitive knowledge on the direct effect of a lightning current involving a module, only conjectures can be made on the failure mode of the panel. As discussed in the preceding paragraph, the presence of damage at the lower half of the panels is somewhat contradictory to the hypothesis of all the damage being done by the lightning current. This contradiction adds weight to the argument (also presented in the case of the Vulcano incident), that the observed damage may be the result of a dc fault current occurring after an initial insulation breakdown caused by an indirect lightning overvoltage induced in the dc circuit. The insulation breakdown would occur at the point of lowest withstand, not necessarily in the upper half of the panel, and the ensuing dc fault would proceed along the edge as the blow-torch effect associated with the high temperatures of the dc arc, lingering at the fault, would cause burning along the edges, similar to what was observed.

On the other hand, the extent of the damage in the E2 B5 box (Photographs 3-10 and 3-11) appears to be greater than what could be expected from the dc current alone. Damage caused by the occurrence of a lightning surge current is a more likely scenario in this case.

3.5.4 Mechanical effects

The top glass cover plates of the damaged modules generally had several cracks, but do not have the frosty appearance associated with the

tempered glass used in the Vulcano module. This difference may provide some clue about the sequence of the scenario, if it could be correlated with the mechanical characteristics of the glass. Damage to the glass during dc faults has been reported in the United States. However, no further detailed information is available in either case to pursue this line of thought. This subject could be part of a test program aimed at finding failure modes of PV modules related to dc faults and lightning (both direct and indirect).

3.5.6 Integrity of the grounding system

The grounding system has been implemented with galvanized steel conductors, in keeping with the standard German practice where concerns over cathodic corrosion have steered designers away from copper. In the salty environment of an island, questions may be raised on the long-term integrity of buried galvanized steel conductors. Even in the dry environment of the array footings, some signs of corrosion are apparent (Photograph 3-40).

3.6 Specific Conclusions from the Kythnos Case

The observed damage to the panels cannot be conclusively attributed to a direct lightning strike. The six reported incidents might involve a combination of effects, with one case involving a direct strike, and the others being an indirect effect. In other words, the evidence that might point to invalidating a particular scenario might not apply to the scenarios of other incidents. The surge-protective devices provided at the site performed well since no damage was inflicted to the electronics. Failure of one surge arrester in the performance of its protective duty can be viewed as the ultimate sacrifice of the device fulfilling its mission – but it raises the question of monitoring for failure of protective devices.

4. General Discussion

4.1 To protect or not to protect ?

The debate on whether to provide protection by air terminals or suffer the consequences of a direct strike is not settled by these case histories. In spite of the presence of air terminals at Kythnos, damage occurred. This damage may be a direct effect, or may be an indirect effect, or a combination of both. At Vulcano, with no air terminals, only one case of lightning-related damage has occurred, and this single case may be an indirect effect rather than a direct effect. Indirect effects are not eliminated by air terminals. A better argument could be made if a firm conclusion were reached on whether the damage was a direct or indirect effect.

If the damage is attributed to direct effects, then the conclusion is that the air terminals, at the spacing and height used at Kythnos, were ineffective. However, precisely because air terminals were distributed perhaps too sparsely, the Kythnos case history does not invalidate protection if it were ensured by appropriate air terminals with adequate height and density.

If the damage is attributed to an indirect effect, then one would argue that the air terminals cannot serve any useful purpose – the counter-argument being that the direct damage would have been even worse than what actually occurred.

4.2 Grounding practices

Differences in grounding practices leave many questions unanswered. On the materials aspects, there is the different approach of using copper or of using galvanized steel. On the circuitry aspects, there is the issue of grounding the dc circuit or leaving it floating (but with a ground fault detection scheme). This latter choice, however, raises questions on the implementation of a ground fault indication which is

available only to local operators. That design may raise concerns in the context of long-term operation where immediate action on a ground fault may not be perceived as important. This postponing of action may then lead to the occurrence of a second fault caused by lightning or by further pollution of insulation, with damage to components at that time.

4.3 Suggestions for further investigations

The ambiguity on the interpretation of the reported damage gives added weight to the desirability of consolidating all available data on panel failure modes, and eventually performing lightning simulation tests, as well as insulation failure (tracking) tests. Evidence from the lightning damage incident that occurred at the photovoltaic installation of the Sacramento Municipal Utility District (SMUD PV1) in California [7] should be compared to the damage observed at Vulcano and Kythnos.

The conjectural scenario of a nearby lightning strike inducing sparkover at points of weak insulation, followed by damage caused by the dc current, could be more credible if knowledge were available on two parameters: (1) dielectric withstand of the insulation between the modules and their frame, under various conditions of contamination, and (2) levels of the overvoltages that could be induced in the circuits. The first parameter would require tests on the actual configurations, and might be impractical in view of the large number of possible configurations. The second parameter might be evaluated by theoretical analysis, such as that reported Stolte [8].

The ambiguity in the post-mortem may be resolved by further study of the failure modes of a panel (module within its frame) under simulated lightning and under dc stress with

surface contamination. The value of such tests would be to determine the need of further protection or design improvements in the panels to avoid damage, or to better understand the mechanism of the failure in order to settle the dilemma on the exact scenario leading to the observed damage. Ultimately, the knowledge would also provide the basis for an informed decision on the cost-effectiveness of air terminals.

5. General Conclusions

The two case histories presented in this report demonstrate that it is possible to provide protection for the power conversion electronics in the face of inescapable lightning strikes to the array field. In several instances, damage was limited to the modules; the surge protective devices performed their function with no damage to themselves. In one instance, damage was inflicted to the surge protective devices, but even while failing, they protected the expensive downstream circuitry. Depending on the point of view, achieving protection at the cost of a failed protective device may be considered successful, while an alternate view might be to expect protection with no sacrifice of the protective device.

The observations made at these two sites, the evidence collected before the visits, and the preceding discussions lead to a set of conclusions, some still in the form of conjectures, some in the form of firm conclusions. Furthermore, implementation of the recommendations presented here may validate the conjectures and elevate them to the status of firm conclusions. A most important point to bear in mind, however, is that the unpredictability of lightning occurrences make it a risky business to draw sweeping conclusions based on only a few years of observation [6].

Protection against lightning damage to the array modules is a more difficult and less clear-cut issue than operation and survival of protective devices incorporated in the circuit:

- First, there is still some ambiguity in attributing all of the observed damage either to a direct effect of lightning, or to an indirect effect.
- Second, there is no sufficient evidence and long-term data on the effects and costs of a

presumed direct strike to rule out air terminals, although their cost-effectiveness appears questionable.

5.1 Conjectural conclusions

A likely scenario to explain the observed effect is a combination of lightning-induced overvoltages with low insulation withstand. This low withstand may be an inherent limitation of the photovoltaic module layout, or may be the result of pollution or moisture.

The evidence at Vulcano tends to point away from a simple direct lightning strike because the reported damage was limited to the lower part of the array. However, no direct inspection of the failed module was possible in this case.

The overvoltages associated with the one incident at Vulcano were successfully suppressed as no damage was inflicted to either the surge suppressor themselves, the first line of defense, or to the power conversion electronics, the potential victim equipment. However, since the amplitude of the lightning stroke in that incident is not known, the conclusion should not be that protection has been achieved for any level of severity.

The effectiveness of lightning rods appears questionable in view of the several incidents at Kythnos. However, a higher density of rods, or greater height, might have reduced the damage. Nevertheless, the scenario of possible damage by indirect effects leaves in doubt the justification for the expense and disadvantages of providing lightning rods.

5.2 Firm conclusions

The one obvious conclusion, not unexpected, is that lightning does represent a threat to photovoltaic arrays, either by direct damage or by indirect damage.

Good evidence has been provided that surge-protective devices with appropriate ratings (coordinated protection with the equipment to be protected, adequate surge current handling capability, and not excessively low clamping voltage for the systems voltage conditions) can protect the electronic equipment.

The one case of failure of a surge protective device that occurred shows that with suitable failure mode (i.e., short-circuit), protection of the electronics can be obtained for the first incident. However, if the protective devices are associated with fuses, as in the case of Vulcano, failure of the protective device would result in blowing the fuse and, unless an indication of that situation were provided, the equipment would then be left unprotected for the next occurrence.

5.3 Recommendations

The ambiguity in attributing the damage to a direct lightning strike may be reduced if the suggestions proposed in this report for simulated lightning tests and study of failure modes were implemented:

- Establish a common, world-wide data base summarizing all observations of documented or suspected lightning damage to panels.
- Establish a common, world-wide data base summarizing all observations of damage to surge protective devices
- Establish a common, world-wide data base summarizing all observations of documented dc insulation faults on panels.
- Perform laboratory simulation of lightning attachment to panel frames and to module surfaces.

In view of the prevalent practice, with apparent success, among European designers of not grounding the dc system, the quasi-axiomatic

practice by U.S. designers of multiple-point grounding should be re-examined, and a dialogue initiated between the two parties.

Operating procedures associated with the occurrence of the first fault in an isolated dc system should be reviewed and clearly defined.

An intriguing although not crucial question is that of the nature (and thus cost) of the materials used for the ground grid. The Italian practice calls for copper, while the German practice applied in Kythnos calls for galvanized steel. The question of copper versus galvanized steel in this context should be re-examined by specialists of cathodic protection schemes.

6. Acknowledgements

The two site visits described in this report were made possible by the cooperation and hospitality of A. Previ and V. Messina of ENEL, and of J. Chadjivassiliadis and A. Grielas of Public Power. T.S. Key provided insights in reviewing the draft of this report. Funding for this project was provided by the Sandia National Laboratories for the U.S. Department of Energy.

7. References

- [1] Previ, A., "The Vulcano Project," *Int. J. Solar Energy*, 1985, Vol 3, pp 124-141.
- [2] Cianos, N. and Pierce, E.T. "*A ground-lightning environment for engineering usage.*" Stanford Research Institute, Menlo Park, Ca, 1972.
- [3] Martzloff, F.D., "Matching Surge Protective Devices to their Environment," *IEEE Transactions*, Vol IA-21, No.1, January/February 1985.
- [4] Shirakawa, S., F. Endo, H. Kitajima, S. Kobayashi, and K. Kurita, Maintenance of Surge Arrester by a Portable Arrester Leakage Current Detector," *IEEE Transactions*, Vol PD-3, No. 3, July 1988.
- [5] NFPA 78 "*Lightning Protection Code*," National Fire Protection Association, Boston, MA, 1986.
- [6] Golde, R.H., "*Lightning Protection*," Chemical Publishing Company, New York, NY, 1975.
- [7] Collier, D.E., and Key, T.S., "Electrical Fault Protection for a Large Photovoltaic Plant Inverter," *Proceedings, 20th IEEE Photovoltaic Specialist Conference*, September 1988.
- [8] Stolte, W.J., "*Photovoltaic System Grounding and Fault Protection Guidelines*," Contractor Report SAND83-7025, National Technical Information Service, 1985.

U.S. DEPT. OF COMM. BIBLIOGRAPHIC DATA SHEET (See instructions)		1. PUBLICATION OR REPORT NO. NISTIR 89-4113	2. Performing Organ. Report No.	3. Publication Date JUNE 1989
4. TITLE AND SUBTITLE Lightning and Surge Protection of Photovoltaic Installations Two Case Histories: Vulcano and Kythnos				
5. AUTHOR(S) Francois D. Martzloff				
6. PERFORMING ORGANIZATION (If joint or other than NBS, see instructions) U.S. DEPARTMENT OF COMMERCE NATIONAL INSTITUTE OF STANDARDS AND TECHNOLOGY GAITHERSBURG, MD 20899			7. Contract/Grant No.	8. Type of Report & Period Covered
9. SPONSORING ORGANIZATION NAME AND COMPLETE ADDRESS (Street, City, State, ZIP) Sandia National Laboratories Albuquerque, NM 87185-5800				
10. SUPPLEMENTARY NOTES <input type="checkbox"/> Document describes a computer program; SF-185, FIPS Software Summary, is attached.				
11. ABSTRACT (A 200-word or less factual summary of most significant information. If document includes a significant bibliography or literature survey, mention it here) Two installations of photovoltaic systems were damaged during lightning storms. The two sites were visited and the damaged equipment that was still available on the site was examined for analysis of the suspected occurrence. The evidence, however, is insufficient to conclude that all the observed damage was caused by the direct effect of a lightning flash. A possible scenario may be that lightning-induced overvoltages caused insulation breakdown at the edges of the photovoltaic modules, with subsequent damage done by the dc current of the array. Other surge protection considerations are also addressed, and suggestions presented for further investigations.				
12. KEY WORDS (Six to twelve entries; alphabetical order; capitalize only proper names; and separate key words by semicolons) lightning; photovoltaic; surge; varistors				
13. AVAILABILITY <input checked="" type="checkbox"/> Unlimited <input type="checkbox"/> For Official Distribution. Do Not Release to NTIS <input type="checkbox"/> Order From Superintendent of Documents, U.S. Government Printing Office, Washington, D.C. 20402. <input checked="" type="checkbox"/> Order From National Technical Information Service (NTIS), Springfield, VA. 22161			14. NO. OF PRINTED PAGES 76	
			15. Price \$14.95	