

**NATIONAL  
LIGHTING  
PRODUCT  
INFORMATION  
PROGRAM**

# Specifier Reports

## Dimming Electronic Ballasts

High-frequency dimming electronic ballasts designed to operate linear and compact fluorescent lamps

Volume 7 Number 3

October 1999

### Program Sponsors

Energy Center of Wisconsin  
Iowa Energy Center  
Lighting Research Center  
New York State Energy Research  
and Development Authority  
Northwest Energy Efficiency Alliance  
United States Department of Energy  
United States Environmental  
Protection Agency  
United States General Services  
Administration

### Introduction

Dimming electronic ballasts for fluorescent lamps can save energy and increase the range of illuminances provided by a lighting system. A dimming system saves energy relative to a non-dimming system, assuming lamps are dimmed and both systems are operating for similar periods of time. Most dimming electronic ballasts are silent and cause no perceptible flicker. They represent a significant improvement over dimming magnetic ballasts, many of which hum and may cause dimmed lamps to flicker. Control devices for dimming electronic ballasts include automatic and manual dimmers, photo-sensors to dim lamps when daylight is available, and energy management systems that dim lamps during peak demand hours or at night.

### NLPIP Online

NLPIP Online is a service of the Lighting Research Center (LRC). The Web site ([www.lrc.rpi.edu](http://www.lrc.rpi.edu)) contains a full library of NLPIP publications, including *Specifier Reports*, *Lighting Answers*, and searchable manufacturers' data and NLPIP test results. When NLPIP tests new dimming electronic ballasts, the data will be updated online.

**Figure 1. Dimming Electronic Ballasts, Control Devices, and Fluorescent Lamps**



### Contents

Introduction.....	1
Ballast Technology.....	2
Control Signal Circuitry.....	3
Control Devices.....	3
Performance Characteristics.....	4
Alternative Technologies.....	6
Performance Evaluations.....	8
Further Information.....	12
Data Table Terms and Definitions.....	13
Data Tables	
Manufacturer-Supplied Data.....	14
NLPIP Evaluations.....	22
Manufacturer Contact Information.....	22

Dimming electronic ballasts are available for linear fluorescent lamps and compact fluorescent lamps (CFLs). All linear lamps used with dimming electronic ballasts must have the bi-pin bases typical of rapid-start lamps because dimming electronic ballasts supply heating voltage to the lamp electrodes during lamp starting and operation. For the same reason, CFLs used with dimming electronic ballasts require a four-pin base.

Lamp manufacturers offer two types of CFLs: amalgam and non-amalgam. Amalgam CFLs use a mercury amalgam instead of liquid mercury, allowing them to achieve a relatively constant light output over a wide range of temperatures and in different operating positions. However, amalgam CFLs require a longer time to reach full light output after they are switched on and have unpredictable light output under dimmed conditions. The National Lighting Product Information Program (NLPPI) tested both amalgam and non-amalgam CFLs for this report. Table 1 on p. 8 lists the types of lamps used in testing.

Dimming electronic ballasts can be especially cost efficient when combined with controls such as photosensors. In order to calculate life-cycle costs, specifiers must first make application-specific assumptions such as how long, how often, and to what percent lamps will be dimmed. Using these values, total annual energy use and the respective annual costs can be estimated and compared to the estimated energy use and costs for a non-dimming system.

In November 1995, NLPPI published *Specifier Reports: Dimming Electronic Ballasts*, which covered dimming electronic ballasts for linear fluorescent lamps. This report supersedes the 1995 publication. In this issue of *Specifier Reports*, NLPPI addresses the effects of dimming on electrical and photometric parameters of fluorescent lighting systems and provides manufacturer-supplied information and NLPPI testing data for continuous dimming electronic ballasts for 4-foot (ft) [1.2-meter (m)] linear T8 fluorescent lamps and CFQ13, CFQ18, CFQ26, CFM26, CFM32, CFS38, and CFM42 CFLs. This report specifically focuses on ballast-lamp interaction and presents information specifiers need to design systems.

## Ballast Technology

A ballast for a fluorescent lamp has two primary functions: it provides a high initial voltage to start the lamp, and it regulates lamp current during operation. Magnetic ballasts typically operate lamps at 60 hertz (Hz). Common electronic ballasts convert 60-Hz line voltage to a much higher frequency, between 19 and 100 kilohertz (kHz). With the advent of highly efficient electronic ballasts, the fluorescent lighting industry is rapidly progressing toward high-frequency operation of fluorescent lamps. The primary advantage of high-frequency fluorescent lighting is the improvement in efficacy relative to lighting systems with 60-Hz magnetic ballasts. High-frequency operation also reduces the possibility of perceptible lamp flicker that is sometimes associated with low-frequency ballasts because the lamp phosphors are refreshed more often.

### Ballast Types

Ballasts use one of three starting methods, as defined by the American National Standards Institute (ANSI). These are preheat, rapid, or instant. Preheat starting is used primarily by magnetic ballasts for specialty lamps such as 2-ft (0.6-m) fluorescent lamps. Rapid-start ballasts supply electrode-heating voltage during starting and operation. Instant-start ballasts do not provide electrode-heating voltage during starting or operation. All dimming electronic ballasts identified by NLPPI for this report are rapid-start. ANSI does not provide standards for dimming electronic ballasts as of this date.

Rapid-start ballasts provide low voltage of approximately 3.5 volts alternating current (Vac) to the electrodes, heating them to approximately 1800° Fahrenheit (F) [1000° Celsius (C)] in 1 to 2 seconds. Then the ballast applies a starting voltage of 200 to 300 Vac to strike the arc. Rapid-start ballasts start lamps with a brief delay, but without flashing. Recently, a number of ballast manufacturers have introduced ballasts that preheat the lamp electrodes before applying the starting voltage and control the electrical operation during the starting period more accurately than traditional rapid-start ballasts. These

ballasts are generically referred to as *programmed-start* ballasts, but ANSI has not officially adopted a definition for this term. Manufacturers are also developing other rapid-start technologies that have names such as modified rapid-start and controlled rapid-start.

Rapid-start ballasts dim lamps by reducing the effective lamp current. Electrode voltage is concurrently increased to maintain electrode heating. During lamp operation, lamp electrodes should be maintained at a temperature between 1100 and 1800°F (600 and 1000°C) to maximize lamp life. At higher temperatures the emissive coating on lamp electrodes evaporates, and at lower temperatures the electrodes may lose their emissive coating through sputtering.

## Control Signal Circuitry

Dimming electronic ballasts contain one of two types of control circuits: low voltage or high voltage. The control signal range is the range of the electrical signal (in volts) that a control device uses to signal the dimming level to a ballast. Each ballast is designed for a particular control signal range; Tables 2 and 3 list ballasts and their associated control signal ranges.

In addition to their power supply wires, low-voltage dimming electronic ballasts have two wires for a low-voltage control circuit, often rated at 0 to 10 volts direct current (Vdc). The ballast supplies voltage to a control device, such as a photosensor. For full light output on this circuit, the control device returns the maximum control signal to the dimming ballast. For less than full light output, the control device reduces the voltage across the control wires, causing the ballast to dim the lamps. As the control voltage approaches 0 Vdc, the ballast dims the lamps to the lowest light output possible for that system.

High-voltage dimming electronic ballasts do not have additional control wires. Instead, high-voltage control devices such as manual dimmers are typically installed between the electrical supply and the “hot” lead of the ballast and can be used to replace light switches.

## Control Devices

Control devices (shown in Figure 2) are available for a wide variety of applications. Many dimming control devices can operate more than one ballast simultaneously. Manual dimmers are designed to replace standard wall switches. Automatic timers are control devices that can automatically dim lights at predetermined hours. Automated control devices operate with or without regular user control.

Photosensors can be used when daylight is available in a space or for lumen maintenance control. The photosensor detects the light in a space, then adjusts the control signal to maintain a relatively constant level of light. Occupancy sensors are sometimes used to provide automatic two-level control: maximum light output when they detect motion and reduced light output when they detect no motion. (See *Specifier Reports: Photosensors*, 1998; *Occupancy Sensors*, 1997).

### Programmed-Start Ballasts

Similar to rapid-start ballasts, programmed-start ballasts preheat the lamp electrodes before starting the lamp. These ballasts provide very low lamp starting voltage during the preheat time. This low level of lamp starting voltage helps to reduce glow current and minimize sputtering during lamp starting to better maintain lamp life. After the preheating period, lamp voltage increases to strike the lamp arc.

Figure 2. Control Devices

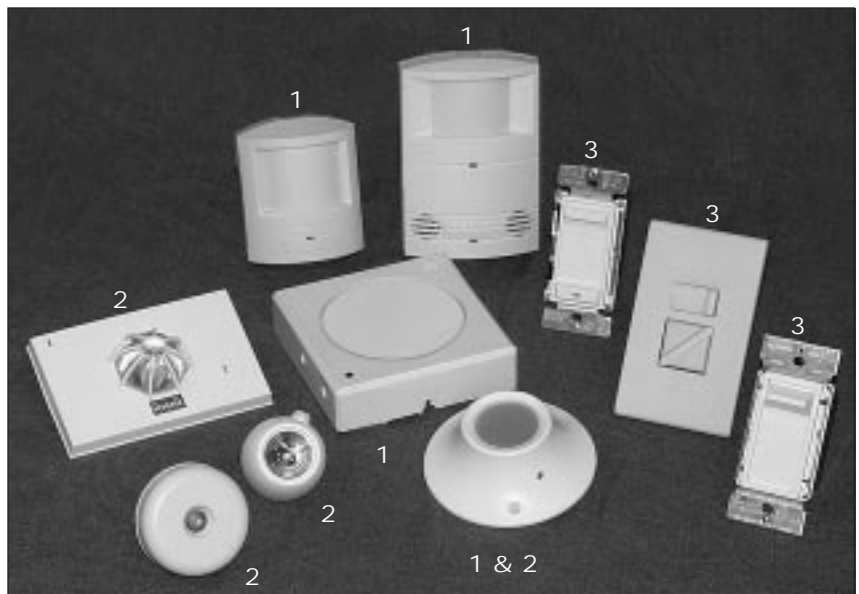

1 occupancy sensors; 2 photosensors; 3 manual dimmers.

## Certifications

### CBM Seal

The Certified Ballast Manufacturers (CBM) consists of manufacturers of fluorescent lamp ballasts who participate in a certification program that requires independent laboratory examination and certification. To bear a CBM seal, a ballast must meet ANSI specifications.

### UL

Underwriters Laboratories (UL) sets safety standards for building materials, electrical appliances, and other products. To be UL listed, the ballast must meet all UL safety requirements.

### CSA

The CSA mark means that the ballast is certified for the Canadian market, following the applicable Canadian standards.

### C-UL

The C-UL listing mark is applied to products for the Canadian market. Products with this mark have been evaluated and found to conform to Canadian safety requirements for the Canadian market.

NLPIP recommends that specifiers select dimming electronic ballasts and control devices that are either made by the same manufacturer or listed in manufacturers' literature as being compatible. Control signal range is key to ballast/control device compatibility and is often reported in manufacturer information. Always specify a control device with a control signal range as close as possible to that of the ballast. A device with a wider control signal range is a better selection than one with a control signal range that does not completely encompass the ballast's effective dimming control range. If the control device's signal range is too great, however, much of its range may produce no response from the ballast and precise control of light output may be more difficult. If the control signal range is less than a ballast's effective dimming control range, the ballast's full dimming range will not be usable.

## Performance Characteristics

### Dimming Operation

Dimming can be described in terms of percentage of maximum light output, measured illuminance, and perceived brightness. Perceived brightness accounts

for the adaptability of the human eye when exposed to different amounts of light. For example, a space with the system dimmed to 25% of maximum light output may be perceived as being almost half as bright as the same space with the system at maximum light output. Figure 3 illustrates the theoretical relationship between measured illuminance and perceived brightness.

NLPIP observed some variations in dimming operation during the testing of dimming electronic ballast systems. All dimmers were supplied by the ballast manufacturers. The manufacturers' information for all of the ballasts tested indicates that each product provides continuous dimming. NLPIP researchers observed "step" dimming characteristics for some systems, in which the light output changed in discrete (and noticeable) steps rather than continuously.

Also, the mechanical range of the slide dimmers used by NLPIP in testing sometimes did not exactly coincide with the dimming range of the lamps and ballasts. The lamps in some cases extinguished before the slide dimmer was at its lowest setting. NLPIP recommends that specifiers obtain samples of the lamps, ballasts, and control devices being considered. These samples should be evaluated in a mock-up before the system is specified and installed.

**Figure 3. "Square Law" Curve: Theoretical Relationship Between Measured Illuminance and Perceived Brightness**

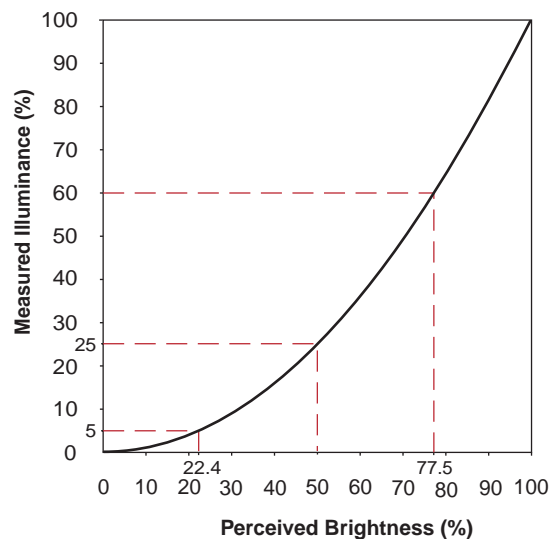

(Adapted from the *Lighting Handbook*, 8th edition)

## Dimming Range

The dimming range of a lighting system varies with different dimming ballasts. NLRIP found that a few of the dimming ballasts tested could dim lamps to less than 5% of maximum light output and that most could dim lamps to less than 20% of maximum light output. The dimming range required for a specific installation depends on the application. A ballast that dims to 20% of maximum light output is adequate for many photosensor applications. Ballasts with a broader dimming range may be preferable for applications where dimming is needed to accommodate audiovisual needs or to create architectural effects.

## Power Quality

Dimming devices can, in some instances, affect power quality. Power quality describes the extent to which a specific electronic device distorts the voltage or current waveform and/or changes the phase relationship between them. A device with ideal power quality characteristics neither distorts the supply voltage nor affects the voltage-current phase relationship. NLRIP evaluated power quality for dimming electronic ballasts by measuring power factor and current total harmonic distortion (THD).

Power factor is defined as the ratio of active power [in watts (W)] to apparent power [in volt-amperes (VA)]. Apparent power is the product of root-mean-square (rms) voltage and rms current. Power factor ranges from 0 to 1. A power factor of 1 means that the current voltage waveforms are in phase and neither waveform is distorted. In other words, when power factor is 1, apparent power and active power are equal.

Any distortion of the current wave shape causes distorted current to flow through the electrical distribution system, thus reducing power factor. These distortions are expressed by current THD. Distorted currents may have other effects, including interference with the operation of electronic equipment, both nearby and remote. High current THD levels can cause overheating in conductors and transformers. For more information, see *Lighting Answers: Electromagnetic Interference Involving Fluorescent Lighting Systems*, 1995, and *Lighting Answers: Power Quality*, 1995.

## Ballast Life

Ballast life is listed in Tables 2 and 3, and ranges from 10 to 20 years. Ballast life depends upon maximum ballast case temperature and operating voltage. High temperatures or high peak voltage can damage electronic components or shorten their lives. Tables 2 and 3 list maximum rated ballast case temperatures for all dimming electronic ballasts supplied by manufacturers. These range from 104 to 185°F (40 to 85°C). If ballasts are operated at temperatures higher than those recommended, warranties could become void. NLRIP did not test ballast case temperatures.

---

### Definition and Standards for Harmonic Distortion

Current THD is a measure of the amount of distortion in a current's wave shape: the higher the THD value, the greater the distortion. American National Standards Institute (ANSI) Standard C82.11 sets a limit of 32% current harmonic factor for electronic ballast systems. The United States Department of Energy has proposed limiting current THD to 20% on all lighting equipment. Many utilities only include ballasts that have THD less than 20% in their energy-efficiency programs.

Harmonics that are odd triple multiples of the fundamental frequency (3rd, 9th, 15th, ...) have the greatest potential impact on electrical systems because the current from these harmonics flows on the neutral conductor and may overload it. ANSI C82.11 also sets limits for odd triple multiples and other harmonics.

In this report, NLRIP uses the definition of the Institute of Electrical and Electronic Engineers (IEEE 519-1992) because that is how ballast manufacturers typically report it. This definition coincides with the definition of harmonic factor used by ANSI, Canadian Standards Association (CSA) and the International Electrotechnical Commission (IEC).

$$\text{THD} = \sqrt{\frac{I_2^2 + I_3^2 + I_4^2 + \dots}{I_1^2}} \times 100$$

where

$I_1$  = fundamental current,  
 $I_2$  = current in second harmonic,  
 $I_3$  = current in third harmonic,  
 $I_4$  = current in fourth harmonic,  
etc.

ANSI, CSA, and IEC define THD as the ratio of the harmonic content to the rms value of the periodic current (all of the harmonic components including the fundamental), which is expressed as

$$\text{THD} = \sqrt{\frac{I_2^2 + I_3^2 + I_4^2 + \dots}{I_1^2 + I_2^2 + I_3^2 + I_4^2 + \dots}} \times 100$$

---

---

## PLC Transmitters and Electronic Ballasts

Interference from high-frequency electronic ballasts may disrupt some power-line carrier (PLC) signals. PLCs are systems that transmit high frequency (50 to 500 kHz) signals via the power lines of a building. These signals control devices such as synchronized clocks or contain voice transmissions such as intercom messages. Some commercial and residential energy management systems also use PLCs. Specifiers should consult the manufacturers of both the PLC device and the electronic ballast to ensure compatibility.

---

## Lamp Starting

Rapid-start ballasts (including dimming electronic ballasts) can reduce lamp life if they do not heat the electrodes enough before starting the lamp. Because electrode temperature cannot be measured directly, the lighting industry uses two related metrics: electrode preheat time and electrode-heating voltage. ANSI specifies a minimum preheat time of 0.5 seconds (s) for rapid-start ballasts and an electrode-heating voltage of 2.5 to 4.4 Vac for non-dimming ballasts operating F32T8 lamps. All dimming electronic ballasts tested by NLPPI preheated lamp electrodes for at least 0.5 s. NLPPI found that at maximum light output, most dimming electronic ballasts provided electrode-heating voltage within the range specified by ANSI.

When lamps are dimmed, the electron flow in the arc decreases. To compensate for this decrease, most ballasts tested by NLPPI exceeded 4.4 Vac of electrode-heating voltage when operating at the minimum light output setting.

In addition to electrode-heating voltage and preheat time, NLPPI has found evidence to support the use of another metric to predict lamp and ballast compatibility for rapid-start electronic ballasts (Davis and Ji 1998).  $R_H/R_C$  is the ratio of hot electrode resistance to cold electrode resistance for each lamp-ballast system as a way to estimate electrode temperature just before a lamp is started (Hammer 1995). An  $R_H/R_C$  value of 4.25 equates to a lamp electrode temperature of 1300°F (700°C), which lamp experts consider the minimum temperature for proper lamp starting. ANSI is currently considering  $R_H/R_C$  as a new metric for determining whether rapid-start lamp-ballast systems adequately heat lamp electrodes before starting. To find out more about  $R_H/R_C$ , see the sidebar on the facing page or NLPPI's *Guide to Selecting Frequently Switched T8 Fluorescent Lamp-Ballast Systems*, 1998.

## Lamp Operation

Ballast factor (BF) is the ratio of the light output of a lamp or lamps operated by a specific ballast to the light output of the same lamp(s) operated by a reference ballast. Most electronic ballasts have BFs less than 1.0, although some electronic ballasts have BFs greater than 1.0 to provide high light output. An electronic ballast with a BF of 1.0 requires less power than a reference ballast, even though they both produce the same light output.

Lamp current crest factor (CCF) is the ratio of peak lamp current to rms lamp current and so is a measure of current wave shape. A high lamp CCF indicates high peaks in the current wave shape that can reduce lamp life. CCF is determined by the ballast. The CCF for a sine wave is 1.41. ANSI specifies CCF less than 1.7 to ensure rated lamp life (ANSI 1993).

## Alternative Technologies

### Lighting Circuit Power Reducers

Lighting circuit power reducers are retrofit devices designed to reduce the energy use of a lighting circuit. These power reducers are installed at electrical panels between a circuit breaker and the lighting load to reduce the active power of the entire lighting circuit. The end result is less power, less illuminance for the space, and in some instances, reduced system efficacy. Specifiers considering this type of retrofit for existing lighting applications should see *Specifier Reports: Lighting Circuit Power Reducers*, 1998.

### Step-Dimming

Another alternative to a continuously dimming electronic ballast is a step-dimming electronic ballast with a built-in switch for selecting preset dim settings. The ballast must be physically accessed to change the settings, so it cannot be remotely controlled. Many controls can be used to step-dim ballasts in a two-level mode (either maximum or reduced light output).

## Fluorescent System Reliability

The rated life of a fluorescent lamp is the number of hours at which half the lamps in a large test group have failed (IESNA 1987). Lamp life testing is performed in a controlled open-air environment. The lamps are cycled continuously on for three hours and off for twenty minutes. This is known as the standard cycling rate. Previous research (Vorlander and Raddin 1950) has shown that starting a lamp more frequently decreases lamp life, while starting it less frequently increases lamp life.

A T8 linear fluorescent lamp typically has a rated life of 20,000 hours. Using the standard cycling rate, it would take three to four years to test these lamps. As a result, when new lamps or ballasts are developed, there is a long delay before a determination can be made about the longevity of a fluorescent system. For this reason, there is interest in developing a life-predicting technique. The technique could be used to test lamp and ballast combinations and determine their compatibility.

One technique that has been used with rapid-start fluorescent systems for the past ten years or more is  $R_H/R_C$ .  $R_H/R_C$  is the ratio of the hot electrode resistance to the cold (or ambient) electrode resistance. The ratio is part of an equation that allows the researcher or designer to predict the temperature of the electrode during starting just before the lamp arc is established. Before starting the lamp, the ballast should heat the electrodes to at least 1300°F (700°C), which equates to an  $R_H/R_C$  value of 4.25. If the electrodes are not heated enough, sputtering will occur, but if they are over-

heated, too much of the emissive coating may evaporate. The relationship between  $R_H/R_C$  and electrode overheating is not known at this time.

Cold electrode resistance can be measured using an ohmmeter capable of measuring low resistances, such as a few ohms. Hot electrode resistance cannot be measured directly. It must be calculated by measuring the voltage applied to the electrode and the electrode current during starting. It is critical to make these measurements just before the lamp arc is established. Several methods of measuring this hot electrode resistance have been presented, most of which are similar in technique.

For this testing, NLPIP used a measurement technique similar to Mortimer (1996). The  $R_C$  was measured at a room temperature of  $77 \pm 2^\circ\text{F}$  ( $25 \pm 1^\circ\text{C}$ ). For the  $R_H$  measurement, the electrode-heating voltage and electrode-heating current values were measured immediately before the lamp's transition from glow to arc. NLPIP calculated the  $R_H$  value and the  $R_H/R_C$  ratio based on these values.

NLPIP measured  $R_H/R_C$  for two different ballasts that were tested in this report. One ballast operated two 26-W CFLs and the other ballast operated one 32-W CFL. For each ballast, nine lamps (three from each of three different lamp manufacturers) were tested. This test demonstrates that  $R_H/R_C$  is dependent on which lamp is used with a particular ballast. However, the data suggest that the differences between ballasts are greater than the differences between lamps. The results are shown in the following table.

Ballast	Lamp	Mean $R_H/R_C$	Range	Standard Deviation
<b>Lutron</b> FDB-CF26-120-2-E	26-W (GE Lighting)	4.08	1.20	0.324
	26-W (OSRAM SYLVANIA)	4.44	0.61	0.177
	26-W (Philips Lighting)	3.64	1.40	0.357
	<b>Average For All 26-W Lamps</b>	<b>4.05</b>		
<b>Prescolite</b> PUV-T13RS-D	32-W (GE Lighting)	5.44	0.66	0.270
	32-W (OSRAM SYLVANIA)	4.55	0.07	0.030
	32-W (Philips Lighting)	5.93	0.88	0.351
	<b>Average For All 32-W Lamps</b>	<b>5.30</b>		

## Switch-Dimming

A third alternative, useful for new construction applications or for extensive lighting renovations, is to wire lamps within luminaires to different control circuits. For example, two of the lamps in a three-lamp luminaire can be wired to a control circuit separate from the third lamp. Depending on which circuits are switched on, one, two, or all three lamps can be operated.

## Performance Evaluations

NLPIP tested 120-Vac ballasts for two 32-W T8 lamps (F32T8), two 18-W quad tube lamps (CFQ18), two 26-W quad tube lamps (CFQ26), and one 32-W triple tube lamp (CFM32). NLPIP conducted all testing at the LRC's laboratory in Watervliet, New York, from March to June 1997 and from April to July 1999.

Table 1 contains product information for lamps and luminaires used in NLPIP's testing. Tables 2 and 3 contain manufacturer-supplied product information for dimming electronic ballasts for linear fluorescent and compact fluorescent lamps, respectively. Table 4 contains the results of NLPIP's testing. Table 5 contains a list of manufacturers along with contact information.

### NLPIP Testing Procedure for Dimming Ballasts for T8 Lamps

NLPIP requested three samples of dimming electronic ballasts for two F32T8 lamps and one dimmer from each manufacturer. The dimmers used were not necessarily manufactured by the ballast manufacturers but

were supplied to NLPIP by them. When possible, NLPIP purchased an additional ballast from a local vendor for each manufacturer. One randomly selected ballast from each set was tested with the manufacturer-supplied dimmer. NLPIP used lamps from a single manufacturer (listed in Table 1) to test all the ballasts for a particular lamp type. All lamps were seasoned for at least 100 hours (h) and then operated for at least 15 h immediately before the first measurements. Ambient temperature was maintained at  $77\pm 2^{\circ}\text{F}$  ( $25\pm 1^{\circ}\text{C}$ ) and input voltage at  $120\pm 0.12$  Vac.

Figure 4 illustrates the apparatus for testing dimming ballasts for T8 lamps. NLPIP used a partitioned lamp rack to perform simultaneous electrical and light output measurements. Each lamp compartment was painted black inside and designed to hold one 4-ft (1.2-m) lamp and one illuminance detector so that the light output from each lamp could be measured independently. The illuminances from both detectors were added to give the total light output for the system.

NLPIP first took electrical and illuminance measurements at the maximum light output setting of the supplied dimmer for each ballast tested. Then the system was manually dimmed to 80% ( $\pm 3\%$ ) of the maximum illuminance. The same set of measurements was taken after the light output stabilized. NLPIP continuously monitored light output and considered it stabilized when the variation over a five-minute period was less than 2%. This procedure required at least 30 minutes for each measurement. The procedure was repeated with the following light output

**Table 1. Lamps and Luminaires Used in NLPIP Testing**

Lamp Type	Lamp Used		Amalgam (Y/N)	Luminaire Used		
	Manufacturer	Catalog Number		Manufacturer	Housing	Reflector
F32T8	OSRAM SYLVANIA	F32T8/741	N	NA	NA	NA
CFQ18	GE Lighting	F18DBX/SPX27/4P	N	Lightolier	7218F120	8056CLW
CFQ26	OSRAM SYLVANIA	CF26DD/E/827	N	Lightolier	7226F120	8056CLW
CFM32	Philips Lighting	PL-T 32W/30/4P	Y	Lightolier	7132E120	8050CLW

NA = not applicable



levels ( $\pm 3\%$ ) in order: 60%, 40%, 20%, the minimum level (if lower than 20%) achievable with the supplied dimmer, 20%, 40%, 60%, 80%, and finally, the maximum light output level. The values were the same when lamps were measured from minimum to maximum light output and from maximum to minimum light output.

Dimming range, which had an upper limit of 100%, was calculated for each individual ballast. Each ballast's minimum dimmed level is reported as a percentage of its maximum light output in Table 4.

## Results

Table 4 contains data obtained at maximum light output, minimum light output, and 40% of maximum light output. The 40% level was chosen to provide a benchmark to compare dimmed performance. This is the lowest dimmed level that all ballasts met.

## Relative Light Output

To calculate maximum relative light output (RLO), NLRIP normalized the data for all the F32T8 systems to the highest maximum light output measured. This value was assigned an RLO of 100%, and the other data were scaled accordingly. For example, in Table 4, within the F32T8 lamp group, the system using the Philips Lighting ballast with catalog number ECD-120-2/32T had the highest light output, so its RLO was 100%. The light output from the other systems for F32T8 lamps were normalized to this RLO.

RLO correlates with ballast factor because they are both based on light output. For example, the NLRIP-measured data in Table 4 for two F32T8 120-Vac lamps shows that RLO ranged from 100 to 72%. This range correlates with manufacturer-supplied information in Table 2 for the same lamp types, for which ballast factor ranged from 1.00 to 0.74.

## Relative System Efficacy

The efficacy of a lighting system is the ratio of the light output to the active power, calculated in lumens per watt (LPW). For fluorescent lighting systems, system efficacy can range from approximately 60 to 100 LPW. System efficacy depends on the characteristics of individual systems and therefore varies with each application.

Researchers computed relative system efficacy as the ratio of RLO to system active power. Researchers then normalized these relative system efficacy data to the highest value at the maximum light output level, which was assigned a relative system efficacy value of 100%. Figure 5 on p. 10 illustrates the overlapping range of RLOs as the ballasts dim the lamps. These test results were similar for all the ballasts.

**Figure 4. Testing Apparatus for Linear T8 Fluorescent Lamps**

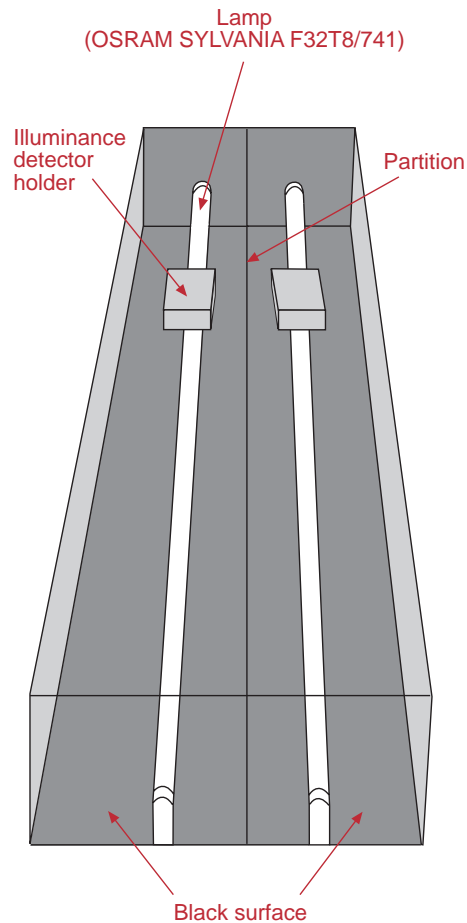

Dimensions: 48 in. (L)  $\times$  18 in. (W)  $\times$  10 $\frac{1}{2}$  in. (H)  
 Each lamp compartment was 9 in. wide  
 1 cm = 0.394 in.

---

### Constraints on Length of Ballast Leads for CFL Products

NLPIP originally planned to test the CFL ballasts with the lamps inside an integrating sphere. However, some CFL ballast manufacturers print lead length constraints on their ballast labels. In the course of discussions with manufacturers, NLPIP learned that the lead length required between the lamp(s) and the ballast is usually less than or equal to 3 ft (0.9 m) and that the proper length leads are usually sent to the customers with the ballasts. According to the manufacturers, longer or shorter leads alter the lamp signal because of varying capacitance, affecting the dimming and starting capability of the lamp.

To evaluate this effect, NLPIP conducted a pilot study with one of the two-lamp dimming electronic ballasts for CFLs. Results showed that when the leads were 3 ft (0.9 m) long, the dimming range was as claimed by the manufacturer (5 to 100% light output). When the leads were 20 ft (6.2 m) long, the lamps extinguished at about 20% light output. At this length, the light output changed considerably when researchers simply moved the wires relative to each other. This lead length constraint made the sphere testing plan impractical and led to NLPIP's decision to test the lamps and ballasts within a luminaire.

---

### NLPIP Testing Procedure for Dimming Electronic Ballasts for CFLs

For commercial applications, dimming systems for CFLs are usually sold as a package including the lamp, ballast, luminaire, and control. For testing purposes, NLPIP researchers selected common downlights for two CFQ18 lamps, two CFQ26 lamps, and one CFM32 lamp. Researchers asked each manufacturer to submit two ballast samples and one dimmer. NLPIP purchased one additional ballast for each manufacturer from an electrical distributor when possible.

Because of maximum lead length constraints (see the sidebar “Constraints on Length of Ballast Leads for CFL Products”), researchers tested the compact fluorescent lamps and dimming ballasts installed in a recessed downlight in a test chamber. Figure 6 shows the simulated ceiling chamber used by NLPIP for testing CFLs.

During testing, NLPIP researchers held the relative positions of the downlight, lamp or lamps, and five illuminance detectors constant. Researchers used the illuminance measurement at the center illuminance detector (see Figure 6) to calculate the RLO for the lamp-ballast

system being tested. Measurements from the other illuminance detectors were monitored to ensure that the luminaire location and the light distribution remained constant. All lamps were seasoned for at least 100 h and then operated for at least 15 h, except for the 32-W amalgam lamp, which was operated for more than 100 h before the first measurements were made. Ambient temperature was maintained at  $77\pm 2^\circ\text{F}$  ( $25\pm 1^\circ\text{C}$ ), and input voltage at  $120\pm 0.12$  Vac.

For each ballast tested that operated non-amalgam lamps, NLPIP researchers followed the same procedure for electrical and light output measurements as those described for the ballasts for T8 lamps. For each ballast tested with the amalgam 32-W CFM lamp, researchers initially used the same testing procedure, but the results were non-repeatable for the middle dimmed levels. Therefore, researchers decided to perform measurements only at the maximum and minimum light outputs achievable with the supplied dimmers.

For CFL dimming electronic ballasts, researchers calculated RLO and relative system efficacy using the method described in testing procedures for T8 lamp ballasts.

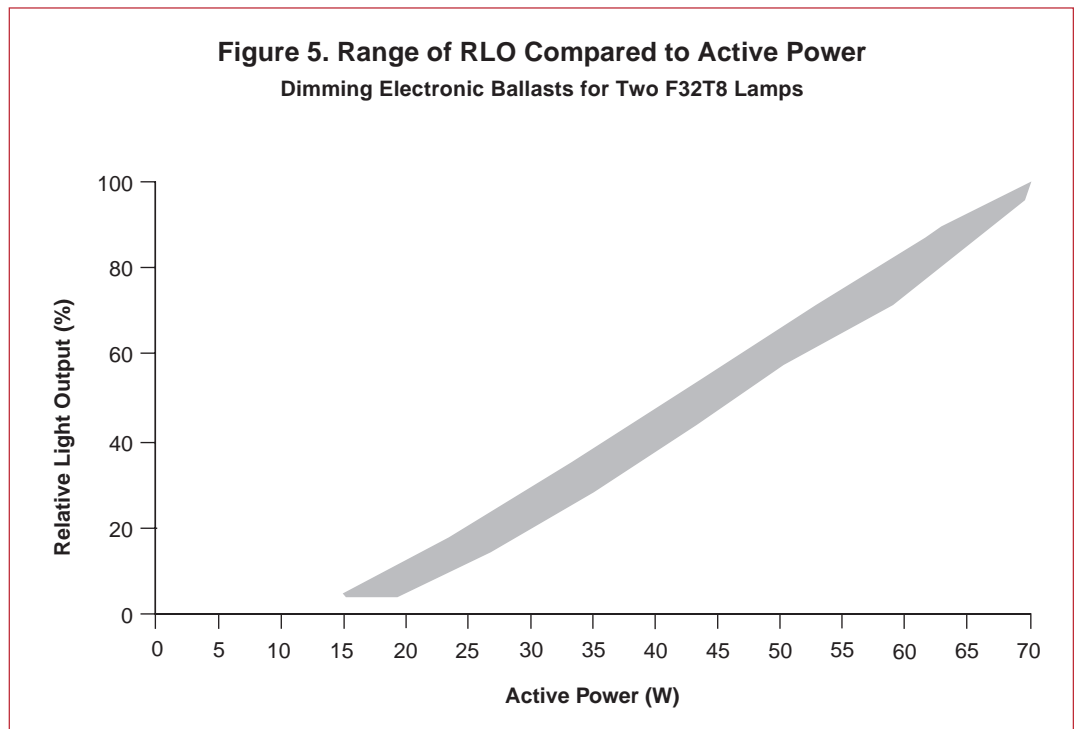

## Results

### Minimum Dimmed Level

In one case (Energy Savings ballast ES-1-CFH-42-120-G-DIM-E), the lamps extinguished before reaching the reported minimum light output level. In another case (Lutron Electronics ballast FDB-CF26-120-2-E), the lamps flickered at the minimum level. For these products, NLPPI reports the measured data at the minimum level achievable without flicker during testing.

### Relative System Efficacy

As reported in Table 4 and shown in Figures 7 and 8, the CFL ballasts tested by NLPPI differed from each other in relative system efficacy. Figure 8 shows the relationship between RLO and active power for the ballasts operating two CFQ26 lamps. This figure illustrates that for the same power, the products tested varied in the light output they produced, resulting in different relative system efficacies. The difference is greater at higher active powers.

As shown in Table 4, dimming electronic ballasts for CFLs tested at maximum light output showed relative system efficacies that ranged from 71 to 100%. Those tested at 40% of maximum showed relative system efficacies that ranged from 70% to 86%. Those tested at minimum light output showed relative system efficacies that ranged from 8 to 62%.

### THD and Power Factor

NLPPI found that the THD produced by a few dimming ballasts increased significantly at dimmed levels. This increase in THD produced a corresponding decrease in power factor. Power factor during dimming ranged from greater than 0.99 at maximum light output to 0.29 at minimum light output. Because THD is expressed as a percentage of the fundamental current, a high THD at low light output levels (and low fundamental current levels) may not be a concern, as the actual distorted current is small. Current THD ranged from 6 to 18% at maximum light output, from 5 to 69% at 40% of maximum, and from 7 to 158% at minimum light output.

**Figure 6. Simulated Ceiling Chamber Used by NLPPI for Testing CFLs**

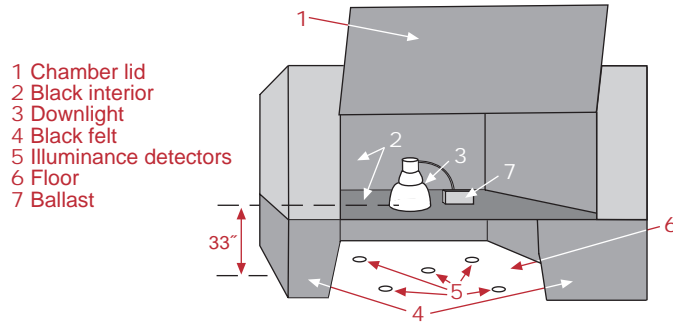

Chamber dimensions: 8 ft (L) × 4 ft (W) × 4 ft (H) and 33 in. above floor  
1 cm = 0.394 in. = 0.0328 ft

**Figure 7. RLO as a Function of Active Power  
Dimming Electronic Ballasts for Two CFQ18 Lamps**

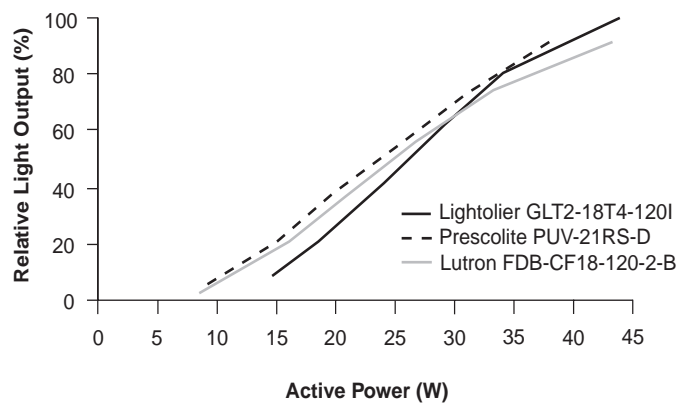

**Figure 8. RLO as a Function of Active Power  
Dimming Electronic Ballasts for Two CFQ26 Lamps**

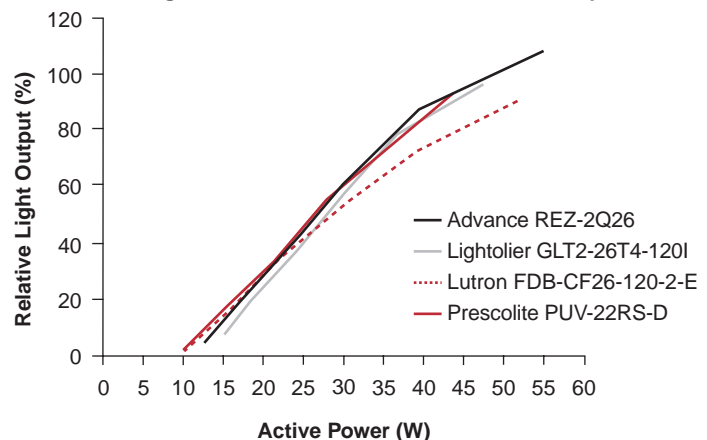

## Further Information

- Abesamis, R.S., P. Black, and J. Kessel. 1990. Field experience with high-frequency ballasts. *IEEE Transactions on Industry Applications* 26(5):810–811.
- American National Standards Institute. 1997. *Lamp ballast – Line frequency fluorescent lamp ballast*, ANSI C82.1-1997. New York, NY: ANSI.
- . 1995. *Fluorescent lamp ballasts: Methods of measurement*, ANSI C82.2-1984 R1995. New York, NY: ANSI.
- . 1993. *High-frequency lamp ballasts*, ANSI C82.11-1993. New York, NY: ANSI.
- Audin, L. 1993. All About Ballasts. *Architectural Record (Lighting Supplement)* 181(2):13.
- Berutti, A., and R.M. Waggoner, eds. 1996. *Practical guide to power quality for sensitive electronic equipment*, 4th edition. Overland Park, KS: Intertec Electrical Group.
- Buddenberg, A., and R. Wolsey. 1995. Compatibility test of dimming electronic ballasts used in daylighting and environment controls. In *Illuminating Engineering Society of North America Annual Conference: Proceedings*, New York, NY, July 30–August 2, 1995. New York, NY: IESNA. pp. 1–9.
- Canadian Standards Association. 1999. *Canadian electrical code - Part 1: Safety for electrical installations*, CSA-C22.1-1999. Toronto, Ontario: Canadian Electrical Association.
- Davis, R.G. and Y. Ji. 1998. *Fluorescent lamp-ballast systems*. Prepared for Empire State Electric Energy Research Corporation. Troy, NY: Lighting Research Center, Rensselaer Polytechnic Institute.
- Electric Power Research Institute, California Energy Commission, and U.S. Department of Energy. 1993. *Advanced lighting guidelines: 1993*, EPRI TR-101022, R1. Palo Alto, CA: EPRI.
- Hammer, E.E. 1995. Cathode fall voltage relationship with fluorescent lamps. *Journal of the Illuminating Engineering Society* 24(1):116–122.
- Illuminating Engineering Society of North America. 1993. *Lighting handbook: Reference & application*, 8<sup>th</sup> ed. Edited by M.S. Rea. New York, NY: IESNA.
- Illuminating Engineering Society Testing Procedures Committee. Subcommittee on Photometry of Light Sources. 1987. *IES approved method for life performance testing of fluorescent lamps*, IES LM-40-1987. New York, NY: Illuminating Engineering Society.
- Institute of Electrical and Electronics Engineers. 1992. *Recommended practices and requirements for harmonic control in electric power systems*, IEEE 519-1992. Piscataway, NJ: IEEE.
- Ji, Y., and R.G. Davis. 1994. *Fluorescent lamp/ballast compatibility*. Troy, NY: Lighting Research Center, Rensselaer Polytechnic Institute.
- Key, T.S. 1979. Diagnosing power quality-related computer problems. *IEEE Transactions on Industry Applications* IA-15(4):381–393.
- Mortimer, G.W. Real-time measurement of dynamic filament resistance. In *Illuminating Engineering Society of North America Annual Conference: Proceedings*, Cleveland, OH, August 5–7, 1996. New York, NY: IESNA. pp. 419–430.
- National Fire Protection Association. 1999. *1999 National electrical code*, NFPA 70. Quincy, MA: NFPA.
- . 1999. *1999 National electrical code handbook*. Quincy, MA: NFPA.
- Underwriters Laboratories. 1998. *Standard for safety: Fluorescent lamp ballasts*, UL-935. 9<sup>th</sup> ed. Northbrook, IL: UL.
- U.S. Bureau of the Census. 1999. Current industrial reports: Fluorescent lamp ballasts summary 1998, Q36C(98). Available at [www.census.gov/ftp/pub/industry/1/mq36c985.pdf](http://www.census.gov/ftp/pub/industry/1/mq36c985.pdf). Accessed 9/9/99.
- U.S. Congress. 1992. *Energy policy act of 1992*. Public Law 102-486. 102<sup>nd</sup> Cong. 24 October 1992.
- . 1988. *An act to amend the energy policy and conservation act to provide for federal energy conservation standards for fluorescent lamp ballasts*. Public Law 100-357. 100<sup>th</sup> Cong. 28 June 1988.
- U.S. Environmental Protection Agency, Green Lights Program. 1998. *Lighting upgrade manual: Lighting waste disposal*. Available at [www.epa.gov/buildings/esbhome/tools/wastedi.pdf](http://www.epa.gov/buildings/esbhome/tools/wastedi.pdf). Accessed 9/9/99.

U.S. Federal Communications Commission. [Latest issue]. *Industrial, scientific, and medical equipment*, 47 CFR 18.

Verderber, R.R., O. Morse, and F. Rubinstein. 1985. Effect of filament power removal on a fluorescent lamp system. 1985 Industry Applications Society Annual Meeting, Toronto, Canada, October 6–11, 1985. New York, NY: IEEE. pp. xxii, 1786.

Vorlander, F.J., and E.H. Raddin. 1950. The effect of operating cycles on fluorescent lamp performance. *Illuminating Engineering* 40(1): 21–27.

## Data Table Terms and Definitions

The following data tables present product information supplied by NLPPI and by manufacturers. The column headings are defined in this section.

Note that for many of the column headings in Tables 2, 3, and 4, there are two sub-headings: Max and Min. The Max column contains data obtained at each dimmer's maximum light output setting. The Min column contains data obtained at each dimmer's minimum setting. Table 4 also contains data obtained at 40% of each dimmer's maximum setting.

**Active power.** The input power (in watts) for a lamp and ballast combination.

**BEF (Ballast efficacy factor).** The ratio of the ballast factor (as a percentage) to the active power (in watts). For example, if the ballast factor of a ballast is 0.88 and its active power is 33W, the ballast's BEF is  $88 \div 33 = 2.67\%/W$ .

**BF (Ballast factor).** The ratio of the light output of a fluorescent lamp operated by a particular ballast to the light output of the same lamp operated by a reference ballast under standard testing conditions, given as a percentage.

**CCF (Current crest factor).** The peak lamp current divided by the root-mean-square (rms) lamp current. CCF ranges from 1.0 to infinity. ANSI requires CCF to be less than 1.7; lamp manufacturers usually will not warranty their lamps if operated on ballasts with CCFs greater than 1.7.

**Control signal range.** The range of the electrical signal (in volts) that a control

device uses to signal the dimming level to a ballast.

**Current THD.** A measure of the degree to which the current waveform deviates from sinusoidal, expressed as a percentage.

**Glow current.** The current that flows from the lamp electrodes during the electrode preheat period while the lamp starting voltage is applied.

**Lamp current.** The current flowing between the lamp electrodes during operation.

**Low-voltage circuit protection.** Protection for the ballast's low-voltage control circuit from high voltage spikes. Does not apply to high-voltage controls.

**Maximum ballast case temperature.** The maximum temperature of the ballast case for which the manufacturer's life rating is valid.

**Maximum relative light output.** The illuminance measured at a fixed distance from the lamps. For each lamp type, the maximum relative light output was normalized to the highest value at the maximum light output level, which was assigned a value of 100%.

**Minimum dimmed level.** The lowest dimmed level achieved by the ballast, expressed as a percentage of that ballast's maximum light output.

**Minimum starting temperature.** The minimum ambient temperature at which the ballast will reliably start fluorescent lamps.

**Operating electrode voltage.** The voltage that the ballast supplies to the lamp electrodes while the lamp is operating.

**Power factor.** The ratio of active power (in watts) to apparent power (in rms volt-amperes).

**Relative system efficacy.** The ratio of relative light output (RLO) to system active power. For each lamp type, relative system efficacy was normalized to the highest value at the maximum light output level, which was assigned a relative system efficacy value of 100%.

**Starting method.** All the dimming electronic ballasts in this report use one of these starting methods: rapid-start (RS), programmed-start (PS), or controlled rapid-start (CRS).

**Table 2. Manufacturer-Supplied Data: Dimming Electronic Ballasts for Linear Fluorescent Lamps**

Manufacturer	Trade Name	Catalog Number <sup>a</sup>	Electrical Data								
			Power Factor		Current THD		Active Power		Starting Method	Operating Electrode Voltage	
			Max.	Min.	Max. (%)	Min. (%)	Max. (W)	Min. (W)		Max. (Vac)	Min. (Vac)
<b>One F32T8 Lamp, 120 Vac</b>											
Advance Transformer	Mark VII	RZT-132	>0.98	>0.90	<10	<25	33	9	PS	2.0–4.0	4.0–4.8
	Mark X	REZ-132	>0.98	NA <sup>b</sup>	<10	NA <sup>b</sup>	35	9	PS	2.5–4.5	2.5–5.0
MagneTek	Ballastar	B132R120V20	0.99	0.95	8	15	33	12	RS	3.1–3.2	4.4–5.0
Motorola Lighting	Helios	M1-RN-T8-10C-120	0.99	0.98	<10	<25	34	10	RS	NS	NS
Philips Lighting	Ecotron	ECD-120-1/32T	>0.98	NA <sup>b</sup>	<10	NA <sup>b</sup>	35	9	PS	<4.4	>3.6
<b>One F32T8 Lamp, 277 Vac</b>											
Advance Transformer	Mark VII	VZT-132	>0.98	>0.90	<10	<25	33	9	PS	2.0–4.0	4.0–4.8
	Mark X	VEZ-132	>0.98	NA <sup>b</sup>	<10	NA <sup>b</sup>	35	9	PS	2.0–4.0	4.0–4.8
MagneTek	Ballastar	B132R277V20	0.98	0.94	8	15	33	12	RS	3.1–3.2	4.4–5.0
Motorola Lighting	Helios	M1-RN-T8-10C-277	0.99	0.98	<10	<25	33	10	RS	NS	NS
Philips Lighting	Ecotron	ECD-277-1/32T	>0.98	NA <sup>b</sup>	<10	NA <sup>b</sup>	35	9	PS	<4.4	>3.6
<b>Two F32T8 Lamps, 120 Vac</b>											
Advance Transformer	Mark VII	RZT-2S32	>0.98	>0.90	<10	<25	64	15	PS	2.0–4.0	4.0–4.8
	Mark X	REZ-2S32	>0.98	NA <sup>b</sup>	<10	NA <sup>b</sup>	70	15	PS	2.0–4.0	4.0–4.8
Electronic Lighting	SmartStart Series 700	D232-C120	0.99	0.93	12	33	58	23	CRS	4.0–4.5	4.5–5.0
	SmartStart Series 700 PowerPlus	D232-C120-P3	0.99	0.92	12	37	61	21	CRS	4.0–4.5	4.5–5.0
	SmartStart Series 700 PowerPlus	D232-C120-P3 <sup>c</sup>	0.99	0.94	12	32	61	22	CRS	4.0–4.5	4.5–5.0
Energy Savings	SuperSlim	ES-2-T8-32-120-A-DIM-E	0.99	NS	3	<110	57	15	PS	4.0–5.0	4.0–5.0
Lutron Electronics	ECO-10	ECO-T832-120-2	0.99	0.98	3	13	64	18	RS	3.5–4.5	3.7–4.2
	ECO-10	TVE-T832-120-2	0.99	0.92	8	14	68	17	RS	3.9–4.0	4.0–4.2
	Hilume	FDB-4827-120-2	0.99	0.82	8	16	68	9	RS	3.9–4.0	3.3–3.6
MagneTek	Ballastar	B232SR120V20	>0.99	0.96	5	12	63	20	RS	3.1–3.5	4.0–5.0
Motorola Lighting	Helios	M2-RN-T8-10C-120	0.99	0.98	<10	<25	65	20	RS	NS	NS
Philips Lighting	Ecotron	ECD-120-2/32T	>0.98	NA <sup>b</sup>	<10	NA <sup>b</sup>	70	16	PS	<4.4	>3.6

NA = not applicable

NS = not supplied

°C =  $\frac{5}{9}(\text{°F}-32)$

1 kg = 2.2 lb

<sup>a</sup> Catalog numbers in red indicate products tested by NLPPIP.

<sup>b</sup> Manufacturer claims that power factor at minimum light output, current THD at minimum light output, and control signal range do not depend on the ballast alone; they also depend on the control device used.

<sup>c</sup> Operated with the dimming module MP3 (allows dimming to 10%).

<sup>d</sup> Prices are retail for small quantity orders.

Electrical Data							Photometric Data			Life			Listed/ Certified By	Min. Start Temp. (°F)	List Price (\$US)	Weight (lb)
Lamp Current		Glow Current (mA)	CCF		Control Signal Range (V)	Low-Voltage Circuit Protection	BF	BEF (%/W)	Min. Dimmed Level (%)	Rated (yr)	Max. Case Temp. (°F)	Warranty (yr)				
Max. (mA)	Min. (mA)		Max.	Min.												
NS	NS	<15	<1.6	<1.6	0-10	NS	0.88	2.67	5	15-20	158	5	UL/CSA	50	70	1.6
NS	NS	NS	<1.7	<1.7	NA <sup>b</sup>	NA	1.00	2.86	5	15-20	158	5	UL/CSA	50	65	1.6
185	33	10	1.4	1.5	0-10	Y	0.88	2.67	20	12-15	167	5	UL/CSA	50	45-50	2.5
180	17	<10	1.4	1.5	0-10	N	0.88	1.36	10	20	104	5	UL/CSA	50	50 <sup>d</sup>	1.3
NS	NS	NS	<1.7	<1.7	NA <sup>b</sup>	NA	1.00	2.86	5	15-20	158	5	UL/CSA	50	NS	1.6
NS	NS	<15	<1.6	<1.6	0-10	NS	0.88	2.67	5	15-20	158	5	UL/CSA	50	74	1.6
NS	NS	<15	<1.6	<1.6	NA <sup>b</sup>	NA	1.00	2.86	5	15-20	158	5	UL/CSA	50	68	1.6
185	33	10	1.4	1.5	0-10	Y	0.88	2.67	20	12-15	167	5	UL/CSA	50	45-50	2.5
180	17	<10	1.4	1.5	0-10	N	0.88	1.36	10	20	104	5	UL/CSA	50	50 <sup>d</sup>	1.3
NS	NS	NS	<1.7	<1.7	NA <sup>b</sup>	NA	1.00	2.86	5	15-20	158	5	UL/CSA	50	NS	1.6
NS	NS	<16	<1.6	<1.6	0-10	NS	0.88	1.36	5	15-20	158	5	UL/CSA	50	67	1.6
NS	NS	<15	<1.6	<1.6	NA <sup>b</sup>	NA	1.00	1.43	5	15-20	158	5	UL/CSA	50	63	1.6
186	33	4	1.7	1.5	0-10	Y	0.86	1.41	20	18	113	5	UL/C-UL	50	35-40	1.3
184	23	4	1.7	1.5	0-10	Y	0.86	1.43	20	18	113	5	UL/C-UL	50	35-40	1.3
184	28	4	1.7	1.4	0-10	Y	0.86	1.43	10	18	115	5	UL/C-UL	50	35-40	1.3
150	20	0	<1.6	<1.6	40-120	NA	0.74	1.29	10	15	185	3	UL/CSA	0	<30	0.5
175	22	<20	1.4	1.4	57-112	NA	0.85	1.33	10	10	167	3	UL/CSA	50	>75	1.0
190	21	<20	1.5	1.8	1-9	Y	0.91	1.34	10	10	167	3	UL/CSA	50	>75	1.0
190	5	<20	1.5	2.5	57-112	NA	0.91	1.34	1	10	167	3	UL/CSA	50	>75	1.0
185	35	10	1.4	1.6	0-10	Y	0.88	1.40	20	12-15	167	5	UL/CSA	50	45-50	2.5
180	17	<10	1.4	1.5	0-10	N	0.88	1.36	10	20	104	5	UL/CSA	50	50 <sup>d</sup>	1.3
NS	NS	NS	<1.7	<1.7	NA <sup>b</sup>	NA	1.00	1.43	5	15-20	158	5	UL/CSA	50	NS	1.6

**Table 2 (continued). Manufacturer-Supplied Data: Dimming Electronic Ballasts for Linear Fluorescent Lamps**

Manufacturer	Trade Name	Catalog Number <sup>a</sup>	Electrical Data								
			Power Factor		Current THD		Active Power		Starting Method	Operating Electrode Voltage	
			Max.	Min.	Max. (%)	Min. (%)	Max. (W)	Min. (W)		Max. (Vac)	Min. (Vac)
<b>Two F32T8 Lamps, 277 Vac</b>											
Advance Transformer	Mark VII	VZT-2S32	>0.98	>0.90	<10	<25	64	15	PS	2.0–4.0	4.0–4.8
	Mark X	VEZ-2S32	>0.98	NA <sup>b</sup>	<10	NA <sup>b</sup>	70	15	PS	2.0–4.0	4.8–4.8
Electronic Lighting	SmartStart Series 700	D232-C277	0.99	0.92	13	34	60	22	CRS	4.0–4.5	4.5–5.0
	SmartStart Series 700 PowerPlus	D232-C277-P3	0.98	0.94	12	28	61	26	CRS	4.0–4.5	4.5–5.0
	SmartStart Series 700 PowerPlus	D232-C277-P3 <sup>c</sup>	0.98	0.93	12	32	61	22	CRS	4.0–4.5	4.5–5.0
MagneTek	Ballastar	B232SR277V20	0.99	0.94	5	12	63	20	RS	3.1–3.5	4.0–5.0
Motorola Lighting	Helios	M2-RN-T8-10C-277	0.99	0.98	<10	<25	65	20	RS	NS	NS
Philips Lighting	Ecotron	ECD-277-2/32T	>0.98	NA <sup>b</sup>	<10	NA <sup>b</sup>	70	16	PS	<4.4	>3.6
<b>Three F32T8 Lamps, 120 Vac</b>											
Advance Transformer	Mark VII	RZT-3S32	>0.98	>0.90	<10	<25	93	20	PS	1.0–4.0	4.0–4.8
	Mark X	REZ-3S32	>0.98	NA <sup>b</sup>	<10	NA <sup>b</sup>	104	20	PS	2.0–4.0	4.0–4.8
Lutron Electronics	ECO-10	ECO-T832-120-3	0.99	0.95	7	13	95	23	RS	4.1–4.2	4.1–4.3
	ECO-10	TVE-T832-120-3	0.99	0.95	7	13	95	23	RS	4.1–4.2	4.1–4.3
	Hilume	FDB-4827-120-3	0.99	0.91	7	15	95	15	RS	4.1–4.2	3.9–4.1
Philips Lighting	Ecotron	ECD-120-3/32T	>0.98	NA <sup>b</sup>	<10	NA <sup>b</sup>	104	20	PS	<4.4	>3.6
<b>Three F32T8 Lamps, 277 Vac</b>											
Advance Transformer	Mark VII	VZT-3S32	>0.98	>0.90	<10	<25	93	20	PS	2.0–4.0	4.0–4.8
	Mark X	VEZ-3S32	>0.98	NA <sup>b</sup>	<10	NA <sup>b</sup>	104	20	PS	2.0–4.0	4.0–4.8
Philips Lighting	Ecotron	ECD-277-3/32T	>0.98	NA <sup>b</sup>	<10	NA <sup>b</sup>	104	20	PS	<4.4	>3.6

NA = not applicable

NS = not supplied

°C =  $\frac{5}{9}(\text{°F}-32)$

1 kg = 2.2 lb

<sup>a</sup> Catalog numbers in red indicate products tested by NLP/IP.

<sup>b</sup> Manufacturer claims that power factor at minimum light output, current THD at minimum light output, and control signal range do not depend on the ballast alone; they also depend on the control device used.

<sup>c</sup> Operated with the dimming module MP3 (allows dimming to 10%).

<sup>d</sup> Prices are retail for small quantity orders.



Electrical Data							Photometric Data			Life			Listed/ Certified By	Min. Start Temp. (°F)	List Price (\$US)	Weight (lb)
Lamp Current		Glow Current (mA)	CCF		Control Signal Range (V)	Low-Voltage Circuit Protection	BF	BEF (%/W)	Min. Dimmed Level (%)	Rated (yr)	Max. Case Temp. (°F)	Warranty (yr)				
Max. (mA)	Min. (mA)		Max.	Min.												
NS	NS	<16	<1.6	<1.6	0–10	NS	0.88	1.38	5	15–20	158	5	UL/CSA	50	70	1.6
NS	NS	<15	<1.6	<1.6	NA <sup>b</sup>	NA	1.00	1.43	5	15–20	158	5	UL/CSA	50	66	1.6
186	34	4	1.7	1.5	0–10	Y	0.86	1.44	20	18	113	5	UL/C-UL	50	35–40	1.3
184	38	4	1.7	1.3	0–10	Y	0.86	1.40	20	18	115	5	UL/C-UL	50	35–40	1.3
184	26	4	1.7	1.4	0–10	Y	0.86	1.40	10	18	115	5	UL/C-UL	50	35–40	1.3
185	35	10	1.4	1.6	0–10	Y	0.88	1.40	20	12–15	167	5	UL/CSA	50	45–50	2.5
180	17	<10	1.4	1.5	0–10	N	0.88	1.36	10	20	104	5	UL/CSA	50	50 <sup>d</sup>	1.3
NS	NS	NS	<1.7	<1.7	NA <sup>b</sup>	NA	1.00	1.43	5	15–20	158	5	UL/CSA	50	NS	1.6
NS	NS	<15	<1.6	<1.6	0–10	NS	0.88	0.95	5	15–20	158	5	UL/CSA	50	80	1.9
NS	NS	<15	<1.6	<1.6	NA <sup>b</sup>	NA	1.00	0.96	5	15–20	158	5	UL/CSA	50	75	1.9
185	21	<20	1.4	1.9	57–112	NA	0.87	0.92	10	10	167	3	UL/CSA	50	>75	1.0
185	21	<20	1.4	1.9	1–9	Y	0.87	0.92	10	10	167	3	UL/CSA	50	>75	1.0
185	8	<20	1.4	2.5	57–112	NA	0.87	0.92	1	10	167	3	UL/CSA	50	>75	1.0
NS	NS	NS	<1.6	<1.7	NA <sup>b</sup>	NA	1.00	0.96	5	15–20	158	5	UL/CSA	50	NS	1.9
NS	NS	<15	<1.6	<1.6	0–10	NS	0.88	0.95	5	15–20	158	5	UL/CSA	50	84	1.9
NS	NS	<15	<1.6	<1.6	NA <sup>b</sup>	NA	1.00	0.96	5	15–20	158	5	UL/CSA	50	79	1.9
NS	NS	NS	<1.7	<1.7	NA <sup>b</sup>	NA	1.00	0.96	5	15–20	158	5	UL/CSA	50	NS	1.9

**Table 3. Manufacturer-Supplied Data: Dimming Electronic Ballasts for Compact Fluorescent Lamps**

Manufacturer	Trade Name	Catalog Number <sup>a</sup>	Electrical Data								
			Power Factor		Current THD		Active Power		Starting Method	Operating Electrode Voltage	
			Max.	Min.	Max. (%)	Min. (%)	Max. (W)	Min. (W)		Max. (Vac)	Min. (Vac)
<b>One CFQ13 Lamp, 120 Vac</b>											
Prescolite	Intelect	PUV-10RS-D	>0.95	>0.95	<10	<10	18	6	RS	3.8–5.5	4.2–6.1
<b>Two CFQ13 Lamps, 120 Vac</b>											
Lightolier	Powerspec	GLT2-13T4-120I	>0.95	0.73	<15	<20	29	10	RS	2.5–3.2	4.4–5.3
Prescolite	Intelect	PUV-20RS-D	>0.95	>0.95	<10	<10	30	NA	RS	3.8–5.5	4.2–6.1
<b>Two CFQ13 Lamps, 277 Vac</b>											
Lightolier	Powerspec	GLT2-13T4-277I	>0.95	>0.95	<15	<20	29	11	RS	2.5–3.2	4.4–5.3
<b>One CFQ18 Lamp, 120 Vac</b>											
Prescolite	Intelect	PUV-11RS-D	>0.95	>0.95	<10	<10	21	7	RS	3.8–5.5	4.2–6.1
<b>Two CFQ18 Lamps, 120 Vac</b>											
Lightolier	Powerspec	GLT2-18T4-120I	>0.95	0.82	<15	<20	35	15	RS	1.2–2.0	2.9–3.8
Lutron Electronics	Hilume	FDB-CF18-120-2-B	0.98	0.80	12	18	38	9	RS	4.6–4.7	4.9–5.0
Prescolite	Intelect	PUV-21RS-D	>0.99	>0.95	<10	<10	37	13	RS	3.8–5.5	4.2–6.1
<b>Two CFQ18 Lamps, 277 Vac</b>											
Lightolier	Powerspec	GLT2-18T4-277I	>0.95	0.84	<15	<20	36	13	RS	1.2–2.0	2.9–3.8
<b>One CFQ26 Lamp, 120 Vac</b>											
Lightolier	Powerspec	GLT1-26T4-120I	>0.95	0.78	<15	<20	26	11	RS	0.8–1.5	2.0–2.6
Prescolite	Intelect	PUV-12RS-D	>0.95	>0.95	<10	<10	23	8	RS	2.7–3.8	3.0–4.2
<b>One CFQ26 Lamp, 277 Vac</b>											
Lightolier	Powerspec	GLT1-26T4-277I	>0.95	0.77	<15	<20	27	11	RS	0.8–1.5	2.0–2.6
<b>Two CFQ26 Lamps, 120 Vac</b>											
Advance Transformer	Mark X	REZ-2Q26	>0.98	NA <sup>b</sup>	<10	NA <sup>b</sup>	58	12	PS	1.5–2.5	>3.6–4.4
Lightolier	Powerspec	GLT2-26T4-120I	>0.95	0.84	<15	<20	48	15	RS	0.8–1.5	2.0–2.6
Lutron Electronics	Hilume	FDB-CF26-120-2-E	0.98	0.84	9	15	49	11	RS	4.0–4.0	3.4–3.5
Prescolite	Intelect	PUV-22RS-D	>0.95	>0.95	<10	<10	42	15	RS	2.7–3.8	3.0–4.2
<b>Two CFQ26 Lamps, 277 Vac</b>											
Advance Transformer	Mark X	VEZ-2Q26	>0.98	NA <sup>b</sup>	<10	NA <sup>b</sup>	58	12	PS	1.5–2.5	>3.6–4.4
Lightolier	Powerspec	GLT2-26T4-277I	>0.95	0.88	<15	<20	46	18	RS	0.8–1.5	2.0–2.6

NA = not applicable

NS = not supplied

°C =  $\frac{5}{9}(\text{°F}-32)$

1 kg = 2.2 lb

<sup>a</sup> Catalog numbers in red indicate products tested by NLIPI.

<sup>b</sup> Manufacturer claims that power factor at minimum light output, current THD at minimum light output, and control signal range do not depend on the ballast alone; they also depend on the control device used.

<sup>c</sup> Data were not supplied for this product because the company is no longer in operation.

Electrical Data							Photometric Data				Life					
Lamp Current		Glow Current (mA)	CCF		Control Signal Range (V)	Low Voltage Circuit Protection (Y/N)	BF	BEF (%/W)	Min. Dimmed Level (%)	Rated (yr)	Max. Case Temp. (°F)	Warranty (yr)	Listed/Certified By	Min. Start Temp. (°F)	List Price (\$US)	Weight (lb)
Max. (mA)	Min. (mA)		Max.	Min.												
168	NS	NS	1.4	1.4	3-10	Y	0.88	4.89	5	20	140	5	UL/CSA	32	NS	0.35
148	8	NS	<1.7	3.1	0-90	NA	NS	NS	10	10	126	3	UL/CSA	50	90-99	1.85
165	NS	NS	1.4	1.4	3-10	Y	0.90	3.00	5	20	140	5	UL/CSA	32	NS	0.35
150	NS	NS	<1.7	<1.5	0-90	NA	NS	NS	10	10	126	3	UL/CSA	50	90-99	1.85
170	NS	NS	1.4	1.4	3-10	Y	0.97	4.61	5	20	140	5	UL/CSA	32	NS	0.35
184	23	NS	<1.7	2.5	0-90	NA	NS	NS	10	10	126	3	UL/CSA	50	90-99	1.85
185	5	<10	1.7	1.6	57-112	NA	0.95	2.50	5	10	164	3	UL/CSA	50	>75	1.00
165	NS	NS	1.4	1.4	3-10	Y	0.97	2.62	5	20	140	5	UL/CSA	32	NS	0.35
118	13	NS	<1.7	1.5	0-90	NA	NS	NS	10	10	126	3	UL/CSA	50	90-99	1.85
238	45	NS	<1.7	1.5	0-90	NA	NS	NS	10	10	126	3	UL/CSA	50	90-99	1.85
170	NS	NS	1.4	1.4	3-10	Y	NS	NS	5	20	140	5	UL/CSA	32	NS	0.35
176	23	NS	<1.7	1.5	0-90	NA	NS	NS	10	10	126	3	UL/CSA	50	90-99	1.85
NS	NS	<5	<1.6	<1.6	NA <sup>b</sup>	NA	1.00	1.72	5	15-20	158	5	UL/CSA	50	65	1.60
188	55	NS	<1.7	3.0	0-90	NA	NS	NS	10	10	126	3	NS	50	90-99	1.85
200	5	<10	1.6	2.0	57-112	NA	0.80	1.63	5	10	167	3	UL/CSA	50	>75	1.00
166	NS	NS	1.4	1.4	3-10	Y	NS	NS	5	20	140	5	UL/CSA	32	NS	0.35
NS	NS	<5	<1.6	<1.6	NA <sup>b</sup>	NA	1.00	1.72	5	15-20	158	5	UL/CSA	50	65	1.60
212	28	NS	<1.7	1.5	0-90	NA	NS	NS	15	10	126	3	NS	50	90-99	1.85

**Table 3 (continued). Manufacturer-Supplied Data: Dimming Electronic Ballasts for Compact Fluorescent Lamps**

Manufacturer	Trade Name	Catalog Number <sup>a</sup>	Electrical Data								
			Power Factor		Current THD		Active Power		Starting Method	Operating Electrode Voltage	
			Max.	Min.	Max. (%)	Min. (%)	Max. (W)	Min. (W)		Max. (Vac)	Min. (Vac)
<b>One CFM26 Lamp, 120 Vac</b>											
Advance Transformer	Mark X	REZ-1T32	>0.98	NA <sup>b</sup>	<10	NA <sup>b</sup>	31	9	PS	1.5–2.5	>3.6–4.4
Energy Savings	SuperMini	ES-1-CFH-42-120-G-DIM-E	0.98	NS	15	<110	27	7	PS	1.2–2.0	4.0–5.0
Prescolite	Intelect	PUV-T13RS-D	>0.95	>0.95	<10	<11	32	6	RS	2.7–4.5	2.7–4.5
<b>One CFM26 Lamp, 277 Vac</b>											
Advance Transformer	Mark X	VEZ-1T32	>0.98	NA <sup>b</sup>	<10	NA <sup>b</sup>	32	9	PS	1.5–2.5	>3.6–4.4
Prescolite	Intelect	PUV-T13RS-D	>0.95	>0.57	<10	<45	31	7	RS	2.7–4.5	2.7–4.5
<b>One CFM32 Lamp, 120 Vac</b>											
Advance Transformer	Mark X	REZ-1T32	>0.98	NA <sup>b</sup>	<10	NA <sup>b</sup>	38	10	PS	1.5–2.5	>3.6–4.4
Energy Savings	SuperMini	ES-1-CFH-32-120-G-DIM-E	0.99	NS	10	<110	31	8	PS	1.2–2.0	4.0–5.0
Lutron Electronics	ECO-10	TVE-CT32-120-1	0.97	0.82	10	15	37	10	RS	4.0–4.2	3.2–3.3
	Hilume	FDB-CT32-120-1-E	0.97	0.77	10	16	37	8	RS	4.0–4.2	3.5–3.6
Prescolite	Intelect	PUV-T13RS-D	>0.95	>0.96	<10	<10	38	8	RS	2.7–4.5	2.7–4.5
Solium <sup>c</sup>	NS	31426	NS	NS	NS	NS	NS	NS	NS	NS	NS
<b>One CFM32 Lamp, 277 Vac</b>											
Advance Transformer	Mark X	VEZ-1T32	>0.98	NA <sup>b</sup>	<10	NA <sup>b</sup>	38	10	PS	1.5–2.5	>3.6–4.4
Prescolite	Intelect	PUV-T13RS-D	>0.95	>0.63	<10	<41	37	9	RS	2.7–4.5	2.7–4.5
<b>One CFS38 Lamp, 120 Vac</b>											
Energy Savings	SuperSlim	ES-1-CFT-39-120-A-DIM-E	0.99	NS	5	<110	40	9	PS	1.5–2.0	3.5–4.0
<b>One CFM42 Lamp, 120 Vac</b>											
Advance Transformer	Mark X	REZ-1T42	>0.98	NA <sup>b</sup>	<10	NA <sup>b</sup>	49	11	PS	1.5–2.5	>3.6–4.4
Energy Savings	SuperMini	ES-1-CFH-42-120-G-DIM-E	0.99	NS	7	<110	43	9	PS	0.5–1.0	4.0–5.0
Prescolite	Intelect	PUV-T13RS-D	>0.95	NS	<10	8	44	8	RS	2.7–4.5	2.7–4.5
<b>One CFM42 Lamp, 277 Vac</b>											
Advance Transformer	Mark X	VEZ-1T42	>0.98	NA <sup>b</sup>	<10	NA <sup>b</sup>	49	10	PS	1.5–2.5	>3.6–4.4
Prescolite	Intelect	PUV-T13RS-D	>0.95	NS	<10	45	42	8	RS	2.7–4.5	2.7–4.5

NA = not applicable

NS = not supplied

°C =  $\frac{5}{9}(\text{°F}-32)$

1 kg = 2.2 lb

<sup>a</sup> Catalog numbers in red indicate products tested by NLPPI.

<sup>b</sup> Manufacturer claims that power factor at minimum light output, current THD at minimum light output, and control signal range do not depend on the ballast alone; they also depend on the control device used.

<sup>c</sup> Data were not supplied for this product because the company is no longer in operation.

Electrical Data							Photometric Data				Life					
Lamp Current		Glow Current (mA)	CCF		Control Signal Range (V)	Low Voltage Circuit Protection	BF	BEF (%/W)	Min. Dimmed Level (%)	Rated (yr)	Max. Case Temp. (°F)	Warranty (yr)	Listed/Certified By	Min. Start Temp. (°F)	List Price (\$US)	Weight (lb)
Max. (mA)	Min. (mA)		Max.	Min.												
NS	NS	NS	<1.6	<1.6	NA <sup>b</sup>	NA	1.00	3.23	5	15–20	158	5	UL/CSA	50	65	1.60
275	12	0	<1.6	<1.6	40–120	NA	NS	NS	10	15	140	3	UL/CSA	0	<30	0.39
276	7	NS	1.5	1.3	3–12	Y	0.95	2.96	5	20	140	5	UL/CSA	32	NS	0.35
NS	NS	<5	<1.6	<1.6	NA <sup>b</sup>	NA	1.00	3.13	5	15–20	158	5	UL/CSA	50	65	1.60
274	7	NS	1.5	1.3	3–12	Y	0.95	3.06	5	20	140	5	UL/CSA	32	NS	0.39
NS	NS	<5	1.6	<1.6	NA <sup>b</sup>	NA	1.00	2.63	5	15–20	158	5	UL/CSA	50	65	1.60
272	13	0	<1.6	<1.6	40–120	NA	NS	NS	10	15	140	3	UL/CSA	0	<30	0.39
305	28	<10	1.9	1.4	1–9	Y	0.90	2.40	10	10	167	3	UL/CSA	50	>75	1.00
305	15	<10	1.9	2.0	57–112	NA	0.90	2.40	5	10	167	3	UL/CSA	50	>75	1.00
272	7	NA	1.5	1.4	3–12	Y	0.91	2.44	5	20	140	5	UL/CSA	32	NS	0.35
NS	NS	NS	NS	NS	NS	NS	NS	NS	NS	NS	NS	NS	NS	NS	NS	NS
NS	NS	<5	1.6	<1.6	NA <sup>b</sup>	NA	1.00	2.63	5	15–20	158	5	UL/CSA	50	65	1.60
270	7	NS	1.5	1.3	3–12	Y	0.92	2.55	5	20	140	5	UL/CSA	32	NS	0.35
350	13	0	<1.6	<1.6	40–120	NA	NS	NS	10	15	140	3	UL/CSA	0	<30	0.44
NS	NS	<5	1.6	<1.6	NA <sup>b</sup>	NA	1.00	2.04	5	15–20	158	5	UL/CSA	50	70	1.60
253	16	0	<1.6	<1.6	40–120	NA	NS	NS	10	15	140	3	UL/CSA	0	<30	0.39
275	5	NS	1.5	1.4	3–12	Y	NS	NS	5	20	140	5	UL/CSA	32	NS	0.35
NS	NS	<5	1.6	<1.6	NA <sup>b</sup>	NA	1.00	2.04	5	15–20	158	5	UL/CSA	50	70	1.60
275	5	NS	1.5	1.4	3–12	Y	NS	NS	5	20	140	5	UL/CSA	32	NS	0.35

**Table 4. NLP-IP-Measured Data: Dimming Electronic Ballasts for Compact and Linear Fluorescent Lamps**

Manufacturer	Catalog Number	Minimum Dimmed Level (%)	Active Power		
			Max. (W)	40% of Max. (W)	Min. (W)
<b>Two F32T8 Lamps, 120 Vac</b>					
Advance Transformer	RZT-2S32	6	59	31	13
	REZ-2S32	6	66	35	14
Electronic Lighting	D232-C120	41	59	32	32
	D232-C120-P3	39	60	33	33
Energy Savings	ES-2-T8-32-120-A-DIM-E	6	57	33	17
Lutron Electronics	ECO-T832-120-2	12	63	33	17
	FDB-4827-120-2	5	67	34	13
MagneTek	B232SR120V20	21	60	31	21
Motorola Lighting	M2-RN-T8-10C-120	10	62	35	19
Philips Lighting	ECD-120-2/32T	5	67	35	14
<b>Two CFQ18 Lamps, 120 Vac</b>					
Lightolier	GLT2-18T4-120I	7	43	24	15
Lutron Electronics	FDB-CF18-120-2-B	2	42	21	9
Prescolite	PUV-21RS-D	4	37	20	9
<b>Two CFQ26 Lamps, 120 Vac</b>					
Advance Transformer	REZ-2Q26	5	56	25	13
Lightolier	GLT2-26T4-120I	9	48	25	16
Lutron Electronics	FDB-CF26-120-2-E	3	53	22	11
Prescolite	PUV-22RS-D	6	44	23	12
<b>One CFM32 Lamp, 120 Vac</b>					
Energy Savings	ES-1-CFH-42-120-G-DIM-E	21	33	NT	12
Lutron Electronics	FDB-CT32-120-1-E	2	40	NT	7
Prescolite	PUV-T13RS-D	5	36	NT	8
Solium <sup>a</sup>	31426	34	33	NT	17

NT = not tested due to unstable light output with amalgam lamps.

<sup>a</sup> Manufacturer-supplied data were not supplied for this product because the company is no longer in operation.

**Table 5. Manufacturer Contact Information**

Manufacturer	Telephone Number	Fax Number	Web Site
Advance Transformer	(847) 390-5000 or (800) 322-2086	(847) 390-5109	www.advancetransformer.com
Electronic Lighting	(510) 795-8555	(510) 795-0870	www.elinet.com
Energy Savings	(847) 925-8400	(847) 925-8490	NA
Lightolier	(508) 679-8131	(508) 674-4710	www.lightolier.com
Lutron Electronics	(610) 282-3800	(610) 282-3769	www.lutron.com
MagneTek	(800) 624-6383	(615) 316-5165	www.magnetek.com
Motorola Lighting	(847) 215-6300 or (800) 654-0089	(847) 215-6311	www.mot.com
Philips Lighting	(800) 555-0050	(732) 563-3125	www.lighting.philips.com
Prescolite	(510) 562-3500	(510) 577-5026	www.prescolite.com

NA = not available

Max. Relative Light Output (%)	Relative System Efficacy			Power Factor			Current THD		
	Max. (%)	40% of Max. (%)	Min. (%)	Max. (%)	40% of Max. (%)	Min. (%)	Max. (%)	40% of Max. (%)	Min. (%)
87	99	76	26	>0.99	0.99	0.98	6	11	20
98	99	75	25	0.99	0.72	0.52	13	65	92
86	98	73	73	0.99	0.96	0.96	12	24	24
86	96	70	70	0.99	0.97	0.97	12	21	21
72	85	58	17	0.98	0.62	0.43	9	67	93
87	93	72	40	>0.99	0.99	0.98	2	4	14
96	96	78	24	0.99	0.97	0.87	6	7	9
89	99	77	58	0.99	0.98	0.95	4	6	6
84	92	66	31	0.99	0.97	0.92	10	21	32
100	100	76	24	0.99	0.72	0.47	13	65	98
100	95	71	21	0.96	0.87	0.74	14	25	35
91	88	70	8	0.98	0.95	0.83	6	8	11
91	100	77	14	0.98	0.93	0.85	8	6	7
100	93	86	20	0.99	0.71	0.47	13	69	102
90	97	77	29	0.97	0.90	0.78	12	20	33
84	83	76	14	0.99	0.96	0.86	7	9	12
85	100	77	20	0.97	0.96	0.90	9	5	7
100	100	NT	59	0.99	NT	0.29	7	NT	124
85	71	NT	10	0.98	NT	0.75	8	NT	13
94	87	NT	21	0.98	NT	0.82	6	NT	9
92	93	NT	62	0.98	NT	0.35	18	NT	158

# NATIONAL LIGHTING PRODUCT INFORMATION PROGRAM

## Specifier Reports

### Dimming Electronic Ballasts

Volume 7, Number 3  
October 1999

Principal Investigator: Conan O'Rourke  
Technical Writer: Julie Harrell  
Technical Editor: Alma Taylor  
Program Director: Rick Cobello  
Production Managers: James Gross,  
Susan Mahar  
Graphics and Photography: James Gross,  
Susan Mahar

The following people provided technical review: P. Banwell, U.S. Environmental Protection Agency; F. Barwig, Iowa Energy Center; R. Davis, University of Colorado; D. Grant, Lighting Design Lab; N. Olson, Iowa Energy Center; S. Pigg, Energy Center of Wisconsin; W. VonNeida, U.S. Environmental Protection Agency; and M. Walton, New York State Energy Research and Development Authority. Reviewers are listed to acknowledge their contributions to the final publication. Their approval or endorsement of this report is not necessarily implied.

Production of this report involved important contributions from many staff members at the LRC: S. Hayes, K. Heslin, H. Huang, R. Leslie, M. Morgan, N. Narendran, M. Nickleson, M. Rea, S. Sechrist, S. Vasconez, and K. Wilwol. Special acknowledgment to W. Chen, R. Davis, and Y. Ji for their contributions to this publication.

No portion of this publication or the information contained herein may be duplicated or excerpted in any way in other publications, databases, or any other medium without express written permission of Rensselaer Polytechnic Institute. Making copies of all or part of this publication for any purpose other than for undistributed personal use is a violation of United States copyright laws. It is against the law to inaccurately present information extracted from *Specifier Reports* for product publicity purposes.

The products described herein have not been tested for safety. The Lighting Research Center and Rensselaer Polytechnic Institute make no representations whatsoever with regard to safety of products, in whatever form or combination used, and the results of testing set forth for your information cannot be regarded as a representation that the products are or are not safe to use in any specific situation or that the particular product you purchase will conform to the results found in this report.

© 1999 Rensselaer Polytechnic Institute.  
All Rights Reserved.

## The National Lighting Product Information Program

The National Lighting Product Information Program (NLPIP) was established in 1990 and is administered by the Lighting Research Center at Rensselaer Polytechnic Institute. The Lighting Research Center is a nonprofit educational and research organization dedicated to the advancement of lighting knowledge.

NLPIP's mission is to rapidly provide the best information available on energy-efficient lighting products. NLPIP strives to provide complete, current, and valuable manufacturer-specific performance data in useful formats to guide lighting decisions. Priority is given to information not available or easily accessible from other sources.

NLPIP tests lighting products according to accepted industry procedures. If procedures are not available or applicable, NLPIP develops interim tests, focusing on those performance issues that are important to the lighting specifier and end user. The program does not accept funding from manufacturers.

### Publications:

*Guide to Fluorescent Lamp-Ballast Compatibility*, 1996  
*Guide to Specifying High-Frequency Electronic Ballasts*, 1996  
*Guide to Selecting Frequently Switched T8 Fluorescent Lamp-Ballast Systems*, 1998

### Specifier Reports

*Power Reducers*, 1992; *Specular Reflectors*, 1992; *Parking Lot Luminaires*, 1993; *Cathode-Disconnect Ballasts*, 1993; *Exit Signs*, 1994; *Electronic Ballasts*, 1994; *Reflector Lamps*, 1994; *CFL Downlights*, 1995; *HID Accent Lighting Systems*, 1996; *Occupancy Sensors*, 1997; *Photosensors*, 1998; *Lighting Circuit Power Reducers*, 1998; *Screwbase Compact Fluorescent Lamp Products*, 1999; *Energy-Efficient Ceiling-Mounted Residential Luminaires*, 1999

### Specifier Reports Supplements

*Exit Signs*, 1995, 1998; *Electronic Ballasts*, 1995, 1996, 1997

### Lighting Answers

*T8 Fluorescent Lamps*, 1993; *Multilayer Polarizer Panels*, 1993; *Task Lighting for Offices*, 1994; *Dimming Systems for High-Intensity Discharge Lamps*, 1994; *Electromagnetic Interference Involving Fluorescent Lighting Systems*, 1995; *Power Quality*, 1995; *Thermal Effects in 2'x4' Fluorescent Lighting Systems*, 1995; *T10 and T9 Fluorescent Lamps*, 1995; *T5FT Lamps and Ballasts*, 1996; *Controlling Lighting with Building Automation Systems*, 1997

To view or order publications online, visit the LRC Web site:

[www.lrc.rpi.edu](http://www.lrc.rpi.edu)

or contact:

Lighting Research Center  
Rensselaer Polytechnic Institute  
Troy, NY 12180-3590  
Phone: (518) 276-8717  
Fax: (518) 276-4835  
Email: [lrc@rpi.edu](mailto:lrc@rpi.edu)

# LRC

Lighting Research Center



# Rensselaer



50%  
TOTAL RECYCLED FIBER  
10% POST-CONSUMER FIBER

ISSN 1067-2451