

4. Germanium Resistance Thermometers

Although germanium resistance thermometers are no longer the only, or necessarily the best, choice for high quality temperature measurements below 30 K, they are still widely used and there exists a large literature on their performance which is summarized here. The principal current commercial manufacturers of germanium thermometers are listed in Appendix C.

4.1 Principles and Range of Use

The thermometric quantity is the electrical resistance of a small single-crystal element of doped germanium. The element is mounted so as to permit a four-wire measurement of resistance through very small diameter gold leads bonded to the crystal. The resistivity (ρ) of an intrinsic semi-conductor follows an exponential law but in practice a semi-conductor is rarely intrinsic. It contains donor and acceptor atoms, the relative proportions of which determine the mode of conduction. This leads to a general resistance/temperature relationship with four distinct zones as shown schematically in Fig. 4.1. The useful range of germanium thermometers comprises the two zones below roughly 100 K. The conduction is controlled by the thermal excitation of free carriers. From 1 to 10 K (zone 1) the excitation is from one impurity state to another; from 10 to 100 K (zone 2) it is from impurity states into the conduction band. For details of the basics of germanium thermometers see Kunzler et al. (1962), Lindenfeld (1962), and Blakemore (1962), (1972).

4.2 Fabrication

The relatively low melting point ($\sim 937^\circ\text{C}$) of germanium assures the easy growing of crystals of very high purity. The addition of controlled amounts of impurities (usually arsenic, antimony, or gallium) permits the manufacture of thermometers having approximately the desired resistance for the temperature range of use. In general, type-n thermometers have a more regular resistance/temperature (R/T) characteristic than type-p, as shown in Fig. 4.2. Unfortunately, the germanium resistivity is so sensitive to the impurity concentration that close resistance tolerances in manufacture are not yet achieved; interchangeability, therefore, is not usual with germanium thermometers.

A typical germanium element in a thermometer of current manufacture is shown in Fig. 4.3. Other, and smaller, thermometers with different configuration are also

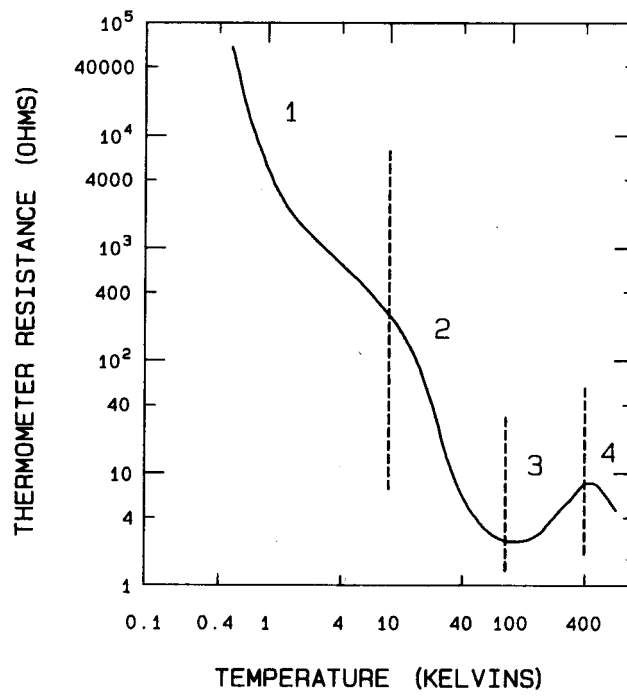

Fig. 4.1: Typical resistance versus temperature response for a germanium resistance thermometer [after Halverson and Johns (1972)].

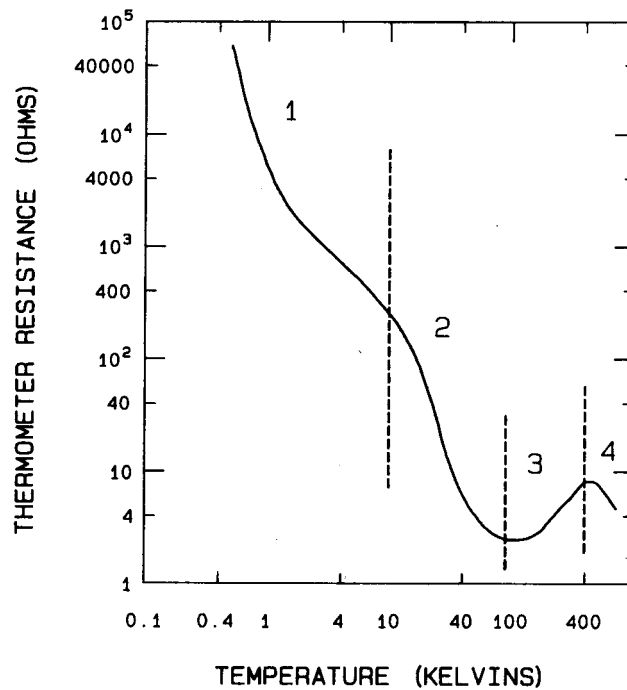

Fig. 4.2: Typical resistance versus temperature response for: (a) n-type germanium (arsenic-doped); (b) p-type germanium [after Blakemore (1972)].

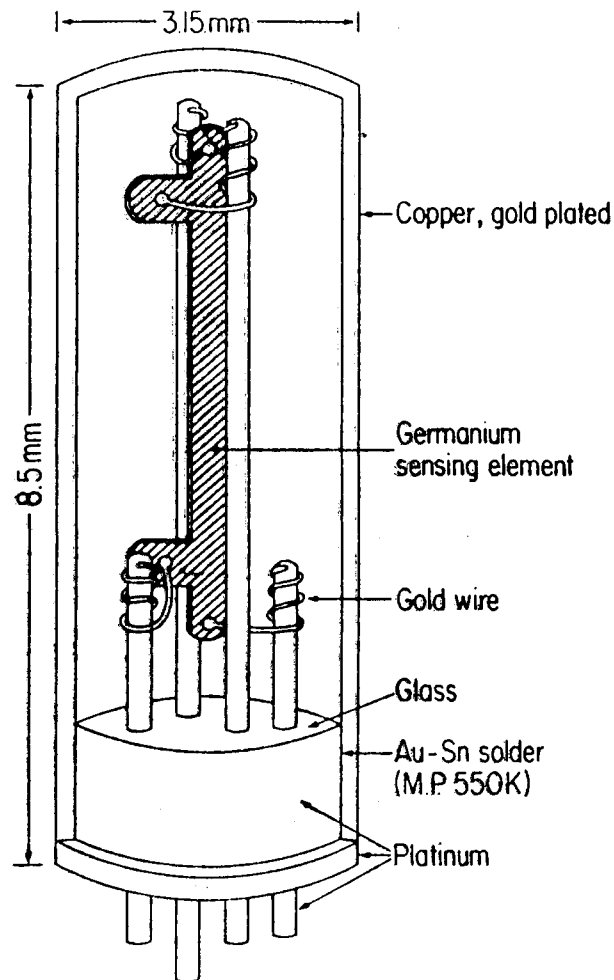

Fig. 4.3: Example of the II-type construction of a germanium thermometer. The germanium is in the form of a bridge, with current contacts on the ends and potential contacts on side arms [Blakemore (1972)].

commercially available. The dimensions are always smaller than 1 cm and the mass less than 1 g, giving the thermometer a small thermal capacity and short response time. Germanium being strongly piezoelectric, it is essential that the element be mounted without mechanical constraints, and this requirement becomes more stringent with higher impurity concentrations. The four electrical leads to the crystal are small diameter gold wires which, because of the fragility of the contacts, are bonded directly to the element. The germanium element is mounted strain-free in a metal capsule that is filled with ^4He or ^3He to improve thermal contact between the element and the surrounds of the capsule. In spite of this, more than two-thirds of the heat exchange is by the leads, so that the indicated temperature is largely a function of their thermal anchoring [Hust (1970)].

4.3 Electrical Characteristics

4.3.1 Method of Measurement

The thermometer resistance is measured either by a potentiometric method or with a resistance bridge. The lead resistances, inherent to the construction of the thermometer, are of the order of 20% to 40% of that of the thermometer itself at a given temperature, and vary with T in the same manner. These can cause systematic temperature-dependent errors associated with the shunting effect of the large-but-finite input impedances of ac bridges. Such errors do not occur with a potentiometer [Swenson and Wolfendale (1973)].

With germanium thermometers, differences occur between the results of ac and dc measurements [Swenson and Wolfendale (1973), Kirby and Laubitz (1973), Anderson and Swenson (1978), and Anderson et al. (1976)]. Resistances measured with alternating current are always smaller than with direct current at a given temperature. This effect, intrinsic to the thermometer and dependent upon its geometry, is due to the Peltier heating and cooling at the current lead contacts to the germanium element. With continuous current it produces temperature gradients between the two ends of the sensor resulting in the development of a thermal emf between the potential contacts. For most applications where millikelvin uncertainty is tolerable, either ac or dc calibrations can be used below 40 K, the effect being of the same order as that due to typical self-heating (see Sec. 4.4.1).

Kirby and Laubitz (1973) on the basis of both a theoretical model and measurements in the range 15 to 1500 Hz, show that the Peltier heating component is damped exponentially with the exponent being proportional to \sqrt{f} . Since the error term is dependent upon the positions of the potential contacts, there is also a difference in the magnitude of the error between 2-lead and 4-lead thermometers. The magnitudes of the errors measured by Swenson and Wolfendale (1973) agree roughly with those of Kirby and Laubitz (1973). The differences between ac (30 Hz) and dc measurements with typical thermometers below 80 K are shown in Fig. 4.4 [Anderson and Swenson (1978)]. The relative differences between ac and dc measurement of resistance are roughly 0.7% at 300 K, 0.2% at 80 K, 0.02% at 50 K, and 0.0001 % below 10 K, with any Peltier error being greater for the dc measurement. If not compensated for, this corresponds to temperature errors of about 0.2 K at 100 K down to 0.1 mK at 20 K. If very precise measurements are needed, the model proposed by Kirby and Laubitz (1973) allows prediction of the systematic errors providing one knows the thermal conductivity and electrical resistivity of the germanium element and the Seebeck coefficient of germanium relative to the material of the leads.

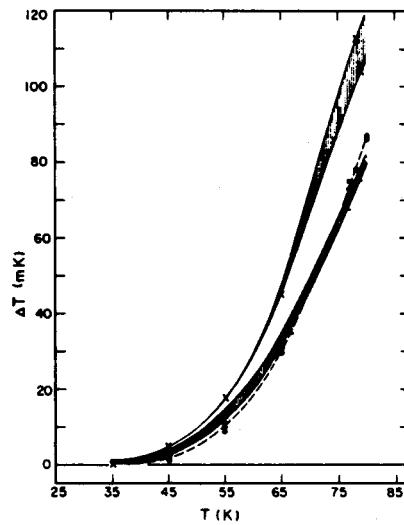

Fig. 4.4: Differences between dc and ac (30 Hz) calibrations for typical germanium thermometers from Minneapolis Honeywell (upper hatched group, 250 to 1250 Ω at 4.2 K), Lake Shore Cryotronics (lower hatched group, 500 Ω at 4.2 K), and CryoCal (dashed curve, 500 Ω at 4.2 K) [after Anderson and Swenson (1978)].

4.3.2 Resistance/Temperature Characteristics and Sensitivity

Typical examples of the variation of resistance (R) with T for commercial germanium thermometers are shown in Fig. 4.5. The resistance at 1 K can be as high as $10^6 \Omega$ and at 100 K as low as 1 Ω , but these are extreme values. For a typical thermometer suited to the temperature range 1 K to 30 K, R ranges from 1000 Ω at 4.2 K to less than 10 Ω at 77 K. The sensitivity (dR/dT) at 4.2 K is about $-500 \Omega K^{-1}$.

In practice the power dissipated in the sensor must be much less than 1 μW , corresponding to a maximum current of 30 μA with a 1000 Ω thermometer, or a voltage across the sensor of 30 mV (see Section 4.4.1 and Fig. 4.8). In order to measure temperatures near 4 K to within 0.01 % (0.5 mK), that would require instrumentation having microvolt resolution. Even lower sensor voltages are desirable, 2 to 4 mV being usual. Commonly, a potentiometric method is used to measure the resistance because of the high resistances involved. At every temperature the current is adjusted to maintain the voltage across the potential terminals as high as compatible with self-heating. This allows one to take advantage of the maximum sensitivity provided by the equipment. Where this procedure is inconvenient, a constant measuring voltage can be used over a wide range and correction made for self-heating (see Sec. 4.4.1).

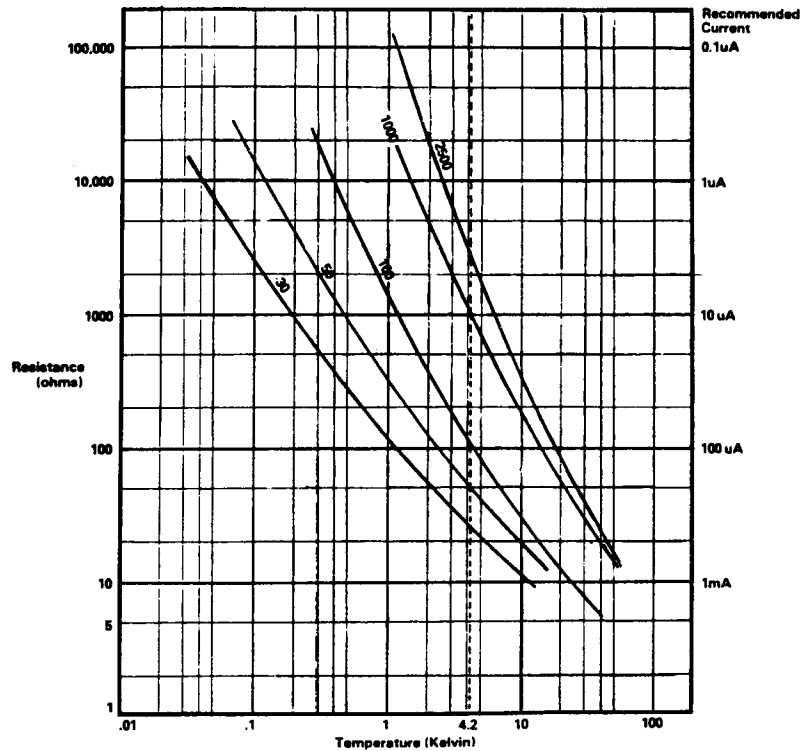

Fig. 4.5: Some typical resistance versus temperature response curves for germanium thermometers.

At very low temperatures the resistance can easily surpass $10^5 \Omega$ so that the measuring current will be of the order of tens of nanoamperes if the power dissipated is to remain tolerable; the tolerable leakage current due to lack of insulation or from the measuring instrument itself must be much smaller. That necessitates a measuring system with excellent signal-to-noise ratio. The very large sensitivity and its rapid change with temperature has both advantages (high precision of measurement) and disadvantages (rather small practical temperature range for any one thermometer).

The complicated behaviour of R and $\frac{1}{R} \frac{dR}{dT}$ as functions of temperature, resulting

from changes in the conduction mechanism in germanium, prevents their being expressed by simple functions. On the other hand, since both the resistivity and its temperature coefficient are strongly influenced by doping, one can obtain thermometers especially adapted to particular uses. For example:

- n-doped thermometers have a relatively smoothly-changing sensitivity, and so a fairly wide temperature range.

- conversely, p-doped thermometers are preferred for use in narrow temperature ranges within which the resistance can be represented precisely by a relation of the form $\ln R = f(\ln T)$ (see Sec. 4.5). The limits of the temperature range can be chosen by suitable control of the doping which, in turn, controls the temperature at which the conduction mode changes (the hump in curve b in Fig. 4.2).

The value of R becomes inconveniently large at very low temperatures. It can be reduced by changing the doping, so it is possible in principle to have a thermometer with 100Ω resistance at 0.1 K, but manufacture becomes more difficult [Halverson and Johns (1972)]. Also, the high magnetoresistance of germanium is often restrictive (see Chapter 17).

4.3.3 Stability

Individual germanium thermometers can exhibit good stability, but many do not. Instabilities are generally not large enough to be significant in applications where an accuracy within 10 mK at 20 K is sufficient. For experiments where $\pm 0.05\%$ uncertainty in temperature is tolerable one can have confidence in the stability of the initial calibration.

Some detailed measurements of instability by Plumb et al. (1977), Besley and Plumb (1978), and Besley (1978), (1980) on about 80 thermometers from 3 manufacturers have shown that a considerable variation in instability occurs during thermal cycling between 20 K and room temperature. Thermometers maintained at a constant temperature can be remarkably stable (much better than 1 mK) but, of course, this type of situation would represent an extremely rare application. After thermal cycling, a variety of types of instability occur, ranging in magnitude from less than a millikelvin to tens of millikelvins. Some thermometer resistances drift slowly but regularly; some can be relatively stable, then jump abruptly by large amounts; some remain stable after a jump but others jump back; some are generally erratic.

It is not possible, a priori, to select stable thermometers. Thermal cycling 10 to 30 times consistent with the eventual use of the thermometer (i.e. rapid cycling if the thermometer will undergo rapid temperature changes; slow cycling otherwise) should routinely be used to detect many unstable ones, but it is not guaranteed that all will be detected. It is obviously useful (and not especially costly) to conserve several of them for periodic intercomparisons with working thermometers so as to identify unstable thermometers. Clearly, also, several thermometers should be used together.

The causes of instability have not been definitively elucidated. There is some suggestion that n-type germanium may be more stable than p-type. However, much of the instability, especially the abrupt jumps, is associated with mechanical shocks; the attachment of the leads to the germanium crystal is particularly vulnerable to damage. Thus it is highly likely that instabilities are geometrical in nature (due especially to change in the geometry of the lead arrangement) and are not caused by fundamental changes in the resistivity of the element. A one-temperature recalibration will not recover the original calibration of an unstable thermometer.

4.3.4 External Influences

- a) Hydrostatic pressure: No change larger than 0.1% in resistance for pressures up to 2×10^5 Pa has been observed [Low (1961)].
- b) Radio frequency fields: Electromagnetic fields in the frequency range 30 to 300 MHz can have a considerable effect on semiconductor thermometers. In the temperature range 70 K to 300 K this can cause a relative error in $\Delta T/T$ of up to 30% [Zawadzki and Sujak (1983)] that varies with frequency and temperature (see Fig. 4.6). Unfortunately, the electromagnetic field strengths for which these data were taken were not reported. At lower temperatures the effect is equally important, but detailed measurements of the magnitude of the error are unavailable. However, at 4 K for example, the thermometer resistance can increase 0.3% in the field of a nearby television transmitter. Obviously, radio frequency shielding is necessary, and the thermometer should be placed perpendicular to the electrical field. For work down to 1 K and germanium thermometer resistances up to $10^5 \Omega$, special precautions are normally unnecessary. Occasionally, however, a thermometer will have a rectifying lead, leading to an extremely noisy off-balance signal. In such a case the thermometer must be discarded.
- c) Magnetic fields: see Chapter 19.

4.4 Thermal Properties

4.4.1 Self-heating and Thermal Anchoring

The passage of current can, by Joule heating, raise the temperature of the sensor above that of the medium in which it is immersed. The increase in temperature is proportional to the Joule heating and inversely proportional to the thermal resistance between the thermometer and the medium. Figure 4.7 shows typical values of the magnitudes of the

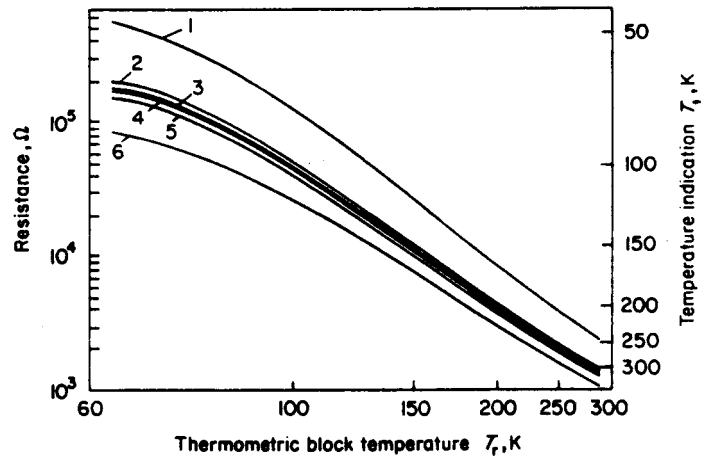

Fig. 4.6: Effect of a radio-frequency electromagnetic field on the response of a germanium thermometer. Curves 1-6 are for external fields of frequency 149 MHz, 170 MHz, no field, 100-200 MHz, 300 MHz, 63 MHz respectively [after Zawadzki and Sujak (1983)].

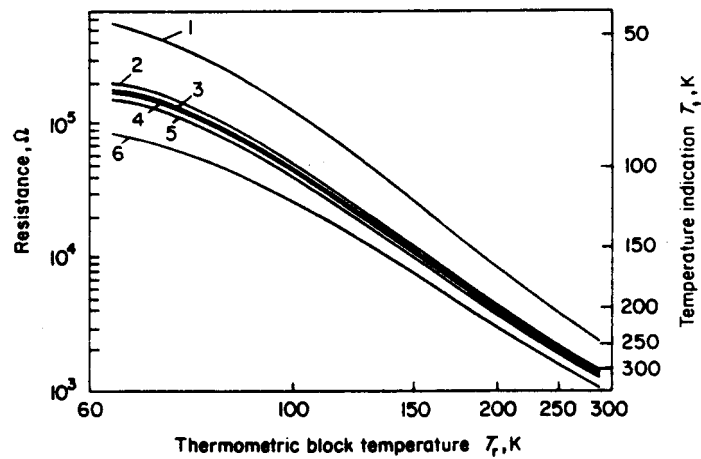

Fig. 4.7: Calibration errors due to self-heating for a germanium resistance thermometer for both constant current and constant voltage operation [Anderson and Swenson (1978)].

effect on temperature measurements under various conditions, indicating that operation at constant voltage rather than at constant current is preferable. As long as the Kapitza resistance can be neglected, the effect varies linearly with the power dissipated and depends upon the effectiveness of the thermal exchange with the environment. When the voltage drop across the potential leads is kept constant, the temperature change due to self-heating varies roughly linearly with temperature below 30 K (Fig. 4.7), independent of thermometer resistance. Rather than calculate powers when the current is changed, it is simpler to maintain a constant voltage and use Fig. 4.7. This is a useful technique when, for example, determining how much self-heating can be tolerated in calorimetric measurements. Another (related) rule-of-thumb can be deduced from Figs. 4.5 and 4.7: for many germanium thermometers, the electrical characteristics are such that $\delta T/T \sim -1/2 \delta V/V$, and so the sensitivity is roughly $1 \mu\text{V}/\text{mK}$.

Figure 4.8 shows the self-heating observed in a large group of thermometers [Besley and Kemp (1977)]. It can be used for any particular thermometer to estimate the self-heating after the values at two or more points have been found. To limit the effect to 1 mK at 4 K, the power dissipated must be less than $0.2 \mu\text{W}$ for a thermometer immersed in liquid helium and less than $0.02 \mu\text{W}$ if it is immersed in helium vapour. The quality of the thermal anchoring can be estimated through the experimental determination of the self-heating effect.

In order to ensure good thermal contact between the thermometer and the body whose temperature is to be measured, several general rules should be followed that depend essentially upon the geometric configuration of the interior of the cryostat. One of the simplest is to provide a well or hole just large enough to accommodate the thermometer so

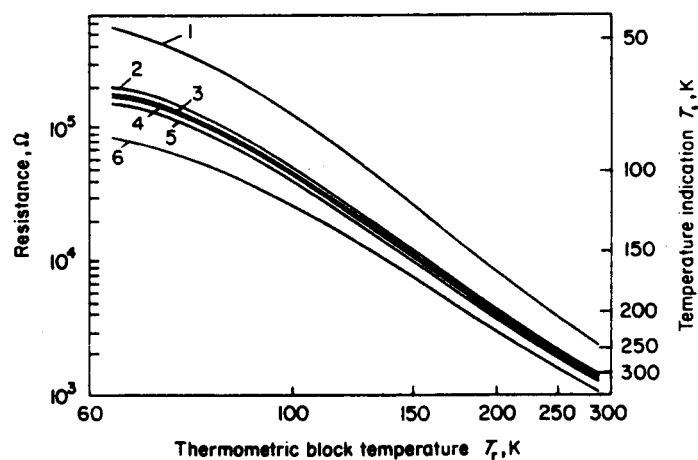

Fig. 4.8: Range of values of self-heating observed with a variety of germanium thermometers [Besley and Kemp (1977)].

that it will not be subject to mechanical constraints, and to fill the remaining gap with a suitable material that allows good heat transfer, such as one of a variety of greases, motor oil, Wood's metal, etc. Anything containing a solvent that can damage the sheath or its seals (which may be an epoxy) should be avoided and, as well, the material should be oxide-free. It is also essential to thermally anchor the leads to the body, or to a shield maintained at the temperature of the body. The leads should be of small diameter (≤ 0.1 mm), electrically insulated, and a considerable length should be attached to the body with, for example, varnish or nail polish [Hust (1970)]. Generally, the largest thermal leak is via the leads.

4.4.2 Time Constant

The value of the time constant depends upon the temperature, the environment, the thermal contact with the environment, and the thermal conductivity of the sheath, lead wires, and other components of the thermometer. It can only be measured in situ. Some typical time constants for germanium thermometers of various types under different conditions are given in Table 4.1 [Blakemore (1972), Halverson and Johns (1972)]. Note that the dimensions and masses of the thermometers do not account for all of the time constant variations. On abruptly cooling a thermometer from 300 K to 4.2 K, about 20 s is required for the thermometer to reach equilibrium.

The time constant increases with temperature because of the rapid increase of the thermal capacity of the thermometer with respect to the thermal conductivity. To minimize the time constant of a germanium thermometer one must ensure that the lead wires are properly thermally anchored as near as possible to the thermometer itself.

4.5 Calibration and Interpolation Formulae

A description of the resistance/temperature characteristics of germanium resistance thermometers is not possible by simple formulae based on theoretical considerations. As the characteristics can be very different from thermometer to thermometer, individual calibrations at a large number of points are necessary. To approximate the characteristic with the minimum possible uncertainty from the experimental data, a suitable fitting method has to be used. Furthermore, the calibration itself should already take into account any peculiarities of the fitting method [Powell et al. (1972)]. The results and conclusions in the literature concerning the efficiency of various fitting methods are obscure and, in some cases, contradictory because

Table 4.1: Typical Time Constants in Helium Liquid and Vapour for Various Germanium Thermometers.

Manufacturer	Thermometer Characteristics	Time Constant (s) in liquid helium	Time Constant (s) in helium vapour at 1.27 cm above the liquid level
Scientific Instruments type p- 1000 Ω at 4.2 K	Mass 0.081 g Length 4.75 mm Diameter 2.36 mm	0.010	0.180
CryoCal type CR1000 type n- 857 Ω at 4.2 K	Mass 0.290 g Length 11 mm Diameter 3.1 mm	0.03	0.200
Honeywell type II (circa 1963)	Mass 0.5 g Length 11 mm Diameter 3.5 mm	0.05	(at 3 cm) 0.38

- only in a few cases are different methods compared directly;
- the results obtained are valid only for the individual thermometer types investigated;
- the uncertainties of the input data are very different in the various papers;
- some questions (for example weighting and smoothing with spline functions) are not sufficiently investigated;
- the mathematical bases are often incompletely described.

Hence it is not possible to give here a recipe which can be applied in all cases. A classification of the various least squares fitting methods with general remarks on their efficiency was made by Fellmuth (1986), (1987). Only one method is recommended here; it allows the characteristics of all germanium resistance thermometers mentioned in Appendix C to be approximated in the temperature range from about 1 K to 30 K with high precision (uncertainty less than 1 mK). The features of this method are:

(i) interpolation equations:

$$\ln T = \sum_{i=0}^n A_i \left(\frac{\ln R - M}{N} \right)^i \quad (4.1)$$

$$\ln R = \sum_{i=0}^n B_i \left(\frac{\ln T - P}{S} \right)^i \quad (4.2)$$

where R is the thermometer resistance, T is the temperature, M and P are origin-shifting constants, N and S are scaling constants, and A_i and B_j are coefficients resulting from the curve fitting.

- (ii) approximation of the characteristic in two subranges which overlap several kelvins (range of overlap about 5 K to 10 K)
- (iii) value of n is about 12 for a range 1 to 30 K, but may be about 5 for the range 1 to 5 K for the same accuracy
- (iv) number of calibration points greater than about $3n$, or $2n$ if the distribution of points is carefully controlled
- (v) calibration points at nearly equal intervals in $\ln T$ except near the ends of any calibration range (and perhaps in the range of overlap), where there should be a distinctly higher density of points. An ideal spacing is such that the m points are distributed according to the formula

$$\frac{x_m + x_1}{2} + \frac{x_m - x_1}{2} \cos\left(\frac{i-1}{m-1}p\right), \quad (i = 1 \text{ to } m)$$

where x_1 and x_m are the lower and upper limits respectively of the independent variable ($\ln R$ or $\ln T$ in equations 4.1 and 4.2 respectively).

Using this method, the errors introduced by spurious oscillations are comparable with the uncertainty of the input data. For the selection of the optimum degree several criteria must be applied (Fellmuth (1986), (1987)], which is easy if orthogonal functions are used.

It is possible that the number of calibrations points can be greatly reduced if the general behaviour of the characteristic of the individual thermometer is known or if a larger uncertainty is tolerable. Unfortunately, in the literature, only isolated data on this matter are available. It must be emphasized that a direct application of literature techniques is only possible if the same type of thermometer is used; and that special interpolation equations can approximate the characteristics of particular types of thermometers sufficiently closely with a lower degree than would result from application of Eq. (4.1) or (4.2), but their use can cause considerable difficulty if these equations are not matched to the characteristic of the individual thermometer to be calibrated.