

LCD screens don't flicker - or do they?

When comparing CRT to LCD screens, one of the most popular differences is the issue of flicker. It is a common assumption that CRT screens flicker while LCD screens do not. In truth, both screens have some amount of flicker. The mechanisms are different and methods for correction have varying amounts of success. This appnote presents the cause of flicker in LCD screens and offers a solution for avoiding flicker by using our ISL45041/2 LCD Module Calibrator in LCD panels.

LCD screens have an array of pixels constantly lit by a backlight. The constancy of the light removes the type of flicker found in CRT screens (phosphors pulsing with each refresh cycle). Instead, an LCD pixel has upper and lower plates with grooves cut perpendicular to each other as in Figure 1. These grooves align the crystals to form channels for the backlight to pass through to the front of the panel. The amount of light emitted depends upon the orientation of the liquid crystals and is proportional to the applied voltage.

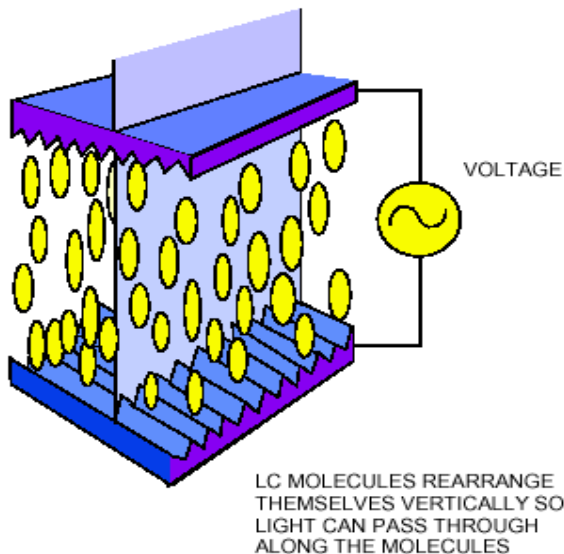

FIGURE 1. SINGLE LCD PIXEL WITH TWO GROOVED PLATES AND LIQUID CRYSTAL MOLECULES

The circuit driving a single LCD pixel is shown in Figure 2. The gate voltage acts as a switch and is commonly amplified to become -5V to 20V. The video source, typically ranging from 0V and 10V, provides the intensity information that appears across the pixel. The bottom of the pixel is commonly connected to the backplane of the panel. The voltage at this node is Vcom.

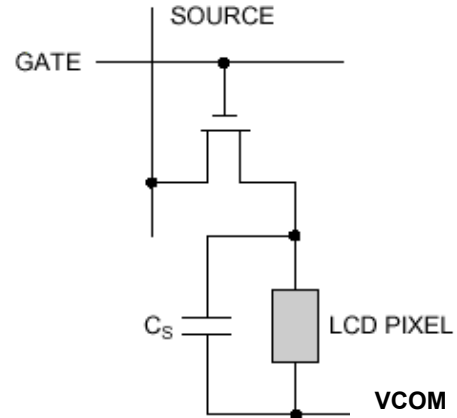

FIGURE 2. CIRCUIT DIAGRAM FOR SINGLE LCD PIXEL

While this set-up is functional, it reduces panel lifetime. Assuming the Vcom voltage is at ground, the voltage across the pixel varies from 0V to 10V. Assuming an average of 5V, there is substantial DC voltage across each pixel. This DC voltage causes charge storage, or memory. In the long term, it is a form of aging, degrading the pixels by electroplating ion impurities onto one of the electrodes of the pixel. This contributes to image retention, commonly known as a sticking image.

The construction of the LCD panel is symmetrical (Figure 1) and either a positive or a negative voltage can be used to align the crystals. One can capitalize on this aspect by moving the common voltage (Figure 2) to the midpoint of the video signal, 5V. Now the video signal swings above and below the common voltage (Vcom), creating a net zero effect on the pixel. This net zero effect on the liquid crystal eliminates the aging and image retention issues. The trade-off for this technique is resolution, since the video signal travels 5V to full brightness instead of 10V.

The Vcom voltage needs to be placed exactly at the midpoint of the video signal to avoid flicker. To illustrate why a panel will flicker, let's assume that due to manufacturing of the panel the Vcom is 5.5V. If the video signal swings between 0V and 10V, the full-scale voltage will be different on each field. On one field, the full-scale voltage will be 4.5V and on the other, the full-scale voltage will be 5.5V. This difference in full-scale voltage translates to a difference in intensity, experienced as flicker.

Due to the variations in construction of each panel, the optimal Vcom voltage can differ from panel to panel or across a single panel. Original Equipment Manufacturers must therefore adjust each of the panels coming out of the

factory to eliminate flicker. For small screens where the backplane can be considered a low-impedance ground, a single potentiometer can be added for common voltage adjustment. Traditionally, this was achieved by using mechanical potentiometers that required additional man-hours (Figure 3). This is acceptable for small panels, even though it is big in size, has low precision, and could easily break during assembly—requiring the replacement of the whole module.

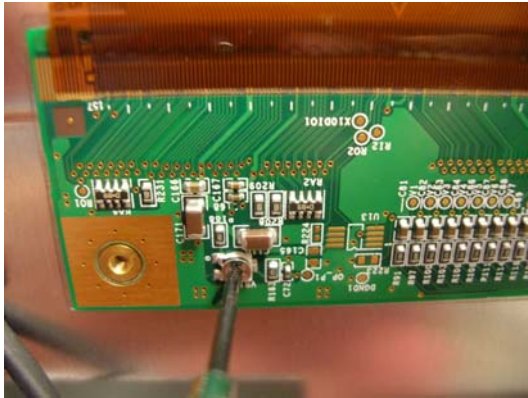

FIGURE 3. ADJUSTMENT OF POTENTIOMETER TO REDUCE FLICKER

For panels exceeding 19", the backplane cannot be considered a single low-impedance node. Multiple corrections are needed in various locations of the screen. There may be up to 5 localized compensation networks, four

in the corners and one in the center. In this case, Digitally Controlled Potentiometers (DCPs) allow the manufacturer to automate the process, a necessity for larger panels where a manual adjustment is not practical.

The system implementation and conversion from a mechanical POT to a DCP is simple. Figure 4 illustrates the system application implementation of a buffered DCP Vcom driver. The ISL45041/2 is a current output, non-volatile DCP that can operate with an AVDD of up to 20V. The ISL45041/2 uses a two-wire, up and down interface. It is an extremely accurate 7-bit device with a resolution of 128 steps. The desired Vcom value can be stored in an on-board EEPROM. The digital circuit voltage range is from 2.25V to 3.6V, this enables it to interface with many controllers used today. The analog voltage supply, running the analog resistor ladder of the device, can operate from 4.5V to 20V. This is an important characteristic for small panels that typically require less than 10V of analog supply, as well as the large panels that may require supply greater than 15V. The DCP output voltage is buffered to the Vcom bus through the EL5111 (180mA output current) amplifier.

Contrary to popular belief, LCD panels do exhibit flicker. Simple potentiometer adjustments can be made to minimize the effect since LCD flicker arises from an offset of the common voltage, not a refresh signal. As LCDs grow in popularity and in size, manual adjustment of a single point on the backplane is no longer possible. Using ISL45041/2 DCP and EL5411 Vcom buffer allow automatic correction of Vcom offsets at multiple sites on the backplane.

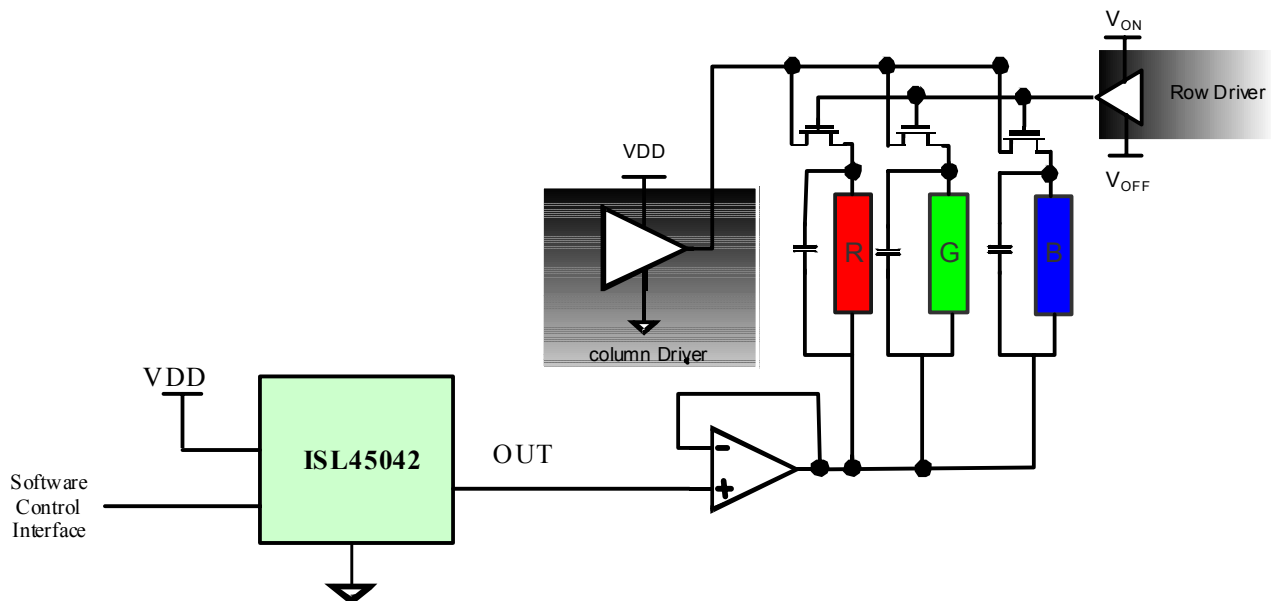

FIGURE 4. DCP SOFTWARE PROGRAMMABLE VCOM IMPLEMENTATION

Intersil Corporation reserves the right to make changes in circuit design, software and/or specifications at any time without notice. Accordingly, the reader is cautioned to verify that the Application Note or Technical Brief is current before proceeding.

For information regarding Intersil Corporation and its products, see www.intersil.com