

Thermistor temperature transducer-to-ADC application

By John Bishop

Applications Specialist, Advanced Analog Products/Op Amp Applications

Introduction

One of the applications of op amps is converting and conditioning signals from transducers into signals that other devices, including analog-to-digital converters (ADCs), can use. The reason any conversion or conditioning is necessary is that the range and offset of the transducer and the ADC are almost never the same.

A very inexpensive temperature transducer uses a diode whose forward-biased junction voltage changes with temperature. When higher repeatability between devices and/or better linearity is needed, other types of transducers, such as the interchangeable thermistor, should be considered.

This application uses an interchangeable negative temperature coefficient (NTC) thermistor device. Because NTC thermistor devices are inherently nonlinear, multiple vendors supply thermistors that contain more than one device, designed for a linear change of resistance with temperature. Since these thermistors are precisely calibrated, they can also be replaced by a part of the same type and still retain their accuracy—in other words, they are interchangeable.

Transducer information

The sensor selected for this application is a thermistor with the part number ACC-004, manufactured by RTI. It has a resistance of 32,650 ohms at 0°C and 678.3 ohms at 100°C.

This part's precision is $\pm 0.2^\circ\text{C}$ (from 0°C to 70°C), but parts are available at a lower cost when less accuracy is required. For instance, part number ACC-024 is a $\pm 1^\circ\text{C}$ part. The specifications for this and similar devices may be found at www.rtie.rti-corp.com/accurv.htm. Another manufacturer of similar devices is Alpha Sensors Inc. Their devices are introduced at www.alphasensors.com/interchange.html.

Current source information

A simple method of obtaining a voltage signal from a thermistor is to measure its resistance by connecting a dc power source through a resistor to the thermistor. The voltage developed across the device will be its resistance times the current through the device (Ohm's law). This method is flawed because the amount of current through the thermistor changes when its resistance changes. Another consideration when designing a thermistor circuit is that when too much current is delivered to the thermistor it "self heats," causing an error in the temperature measurement.

To overcome these errors, a regulated low current (100 μA) is supplied through a current regulator. The one chosen for this circuit is a Texas Instruments REF200. This device contains two current regulators and a current mirror (the current mirror will not be used). It is useful for configuring regulated current sources of varying magnitudes for many applications. A data sheet for this device can be found by searching for REF200 at www.ti.com.

Figure 1. Op amp circuit

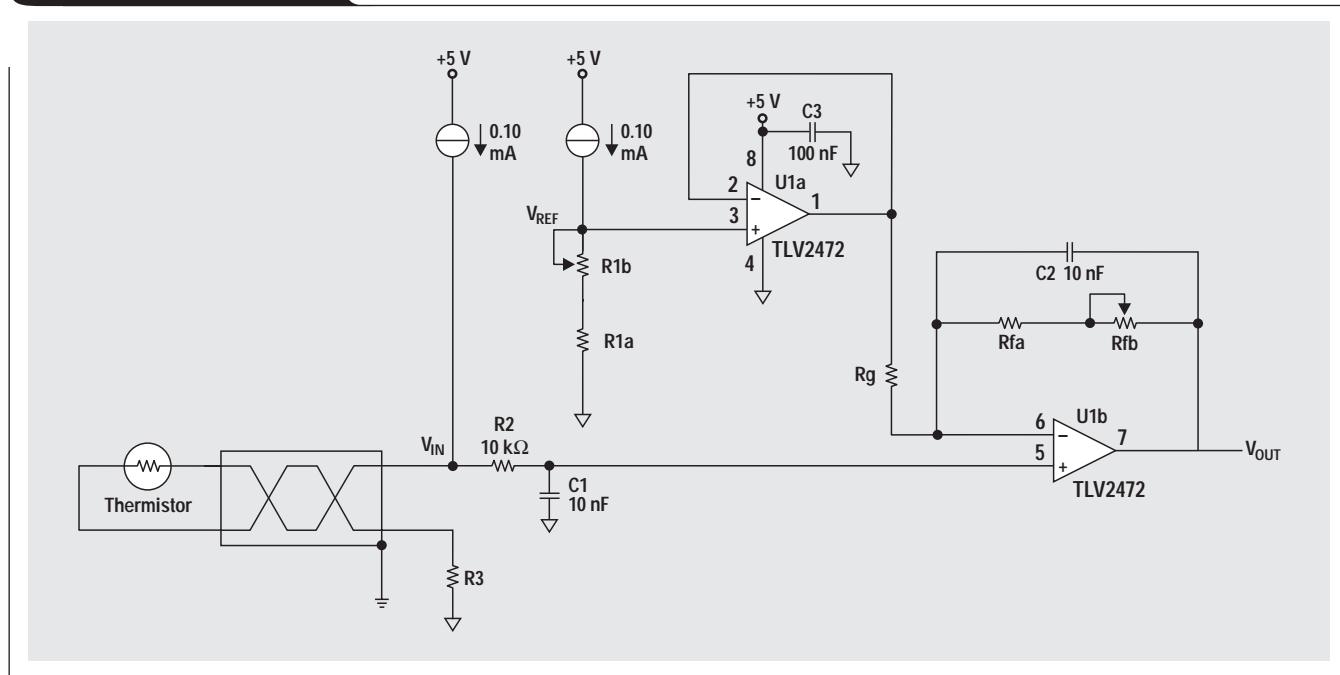

One of the two current regulators supplies $100\ \mu\text{A} \pm 0.5\%$ to the thermistor. From resistance and current information, the thermistor voltage is $0.06783\ \text{V}$ for 100°C and $3.265\ \text{V}$ for 0°C .

Since any current used by the input of the amplifier affects the measured signal, an amplifier with high input impedance is necessary. The number of components in a circuit should be kept to a minimum, because each component that is added increases cost, circuit errors, and complexity. Since fewer components are required to make a noninverting amplifier with high input impedance than an inverting amplifier with high input impedance, the non-inverting configuration was chosen. The output of the ADC will be fed into a digital signal processor (DSP) and inverted there if needed.

The other current source is used to establish the reference voltage in combination with R_1 and $U1a$.

ADC information

Systems engineering selected the TLV2544 ADC for this application. The device is a single-supply unit with an analog input range of 0 to 5 V. The amplified sensor signal should completely fill this span. The voltage required to power this device is from a single 5-V supply. Other ADC devices could be used with corresponding changes in input range, resolution, and input impedance considerations. See "Related Web sites" at the end of this article to locate the data sheet for the TLV2544.

The TLV2544 is a 12-bit ADC, and the voltage value of each bit is calculated as $1.22\ \text{mV/bit}$:

$$\frac{\text{Input}}{\text{Resolution}} = \frac{5}{2^{12} - 1} = 1.22 \frac{\text{mV}}{\text{bit}} \quad (1)$$

Op amp choice

Since the analog input range for this ADC is 0 to 5 V and the power available is a single 5-V supply, a rail-to-rail output (RRO) device is required for best performance. The op amp chosen for this application, TI's TLV2472, will also be able to handle the full input range of the transducer because it is also a rail-to-rail input (RRI) device. See "Related Web sites" at the end of this article to locate the data sheet for this op amp.

In this application, the voltage supplied to the ADC is to be a single 5-V dc. The analog input of the ADC is 0 to 5 V. When a single supply is used, the output range will not quite be able to reach these limits, even on a rail-to-rail op amp. The high output voltage with a $2\text{-k}\Omega$ load is $4.85\ \text{V}$ minimum and $4.96\ \text{V}$ nominal. The low output voltage with a $2\text{-k}\Omega$ load is $150\ \text{mV}$ maximum and $70\ \text{mV}$ nominal. Because the actual load of the ADC is about $20\ \text{k}\Omega$, the actual limits are likely to be better than the nominal limits. Using the nominal limits, the number of codes that will be sacrificed at the high output is $.04/.00122 \approx 33$ bits and at the low output is $.07/.00122 \approx 57$ bits, a total of 90 bits out of 4094 bits. It will allow each $^\circ\text{C}$ to be broken into 40 codes, which is much more resolution than the transducer's accuracy of $\pm 0.2^\circ\text{C}$.

Basic equations

With the previous data, the gain of the circuit can be calculated by dividing the output voltage range by the input voltage range:

$$m = \frac{\text{Output}_{\text{MAX}} - \text{Output}_{\text{MIN}}}{R_{0^\circ\text{C}} I_{\text{SENSOR}} - R_{100^\circ\text{C}} I_{\text{SENSOR}}} = 1.564. \quad (2)$$

Defining the circuit

Figure 1 is a schematic of the op amp circuit for this application.

The temperature of the thermistor is converted into a voltage that is increased by R_3 and amplified by $U1b$. The resistor R_3 is used because it allows for a higher reference voltage. This reference voltage is developed by R_1 and buffered by $U1a$. This higher reference voltage causes the output to move closer to the negative rail at the 100°C point.

Op amp $U1a$ is a unity gain amplifier whose output is the same voltage (but at a lower impedance) as its input. The nominal voltage for V_{REF} is 0.06783 (thermistor voltage at 100°C) plus V_{R_3} (the resistance of R_3 multiplied by $100\ \mu\text{A}$). With R_3 set at $3.01\ \text{k}\Omega$, V_{REF} is calculated as $0.406\ \text{V}$.

The basic voltage signals and resistors in Figure 1 are defined in Equations 3, 4, and 5.

The other op amp, $U1b$, is used to amplify and filter the signal from the thermistor. Equation 3 defines the gain of this op amp:

$$|m| = \frac{R_F}{R_G} + 1. \quad (3)$$

Using the gain of 1.569 and letting $R_G = 26.7\ \text{k}\Omega$ (a 1% value), we can calculate R_F in Equation 3 as $15.056\ \text{k}\Omega$. The closest 1% value for R_F is $15\ \text{k}\Omega$.

Using the equation for a basic voltage divider, we can calculate V_{REF} at a temperature of 100°C :

$$\frac{R_{100^\circ\text{C}} - V_{\text{REF}} - I_{\text{SENSOR}}}{V_{\text{REF}} - \text{Output}_{100^\circ\text{C}}} = \left(\frac{R_F + R_G}{R_G} \right). \quad (4)$$

Substituting values for $R_{100^\circ\text{C}}$, I_{SENSOR} , $\text{Output}_{100^\circ\text{C}}$, R_G , and R_F into Equation 4 yields $V_{\text{REF}} = 0.406\ \text{V}$. Using Ohm's law, we can calculate the value of R_1 :

$$R_1 = \frac{V_{\text{REF}}}{I_{V_{\text{REF}}}} = 4.59\ \text{k}\Omega \text{ (1\% resistor)}. \quad (5)$$

Calibration devices

Because the temperature coefficient of potentiometers is higher (worse) than that of resistors, it is wise to replace R_1 and R_F with a potentiometer in series with a resistor. These parts are designated R_{1A} and R_{FA} for the fixed resistors and R_{1B} and R_{1B} for the potentiometers. In addition, when a fixed resistor is used in series with a potentiometer, adjustment is less critical.

Component values will drift as the components age. Therefore, when the values of R_F and R_1 are calculated, the life expectancy of the application should be taken into account.

Continued on next page

Continued from previous page

Long-life applications

Resistors designated to have 1% tolerance may drift about 3%. The current regulators, temperature sensor, and op amps will drift too. The resistances R_1 and R_F are 4020 Ω and 15 k Ω , respectively, but because of the drift in circuit components, they each must be able to absorb a total of $\pm 9\%$ (3% + 3% + 3%) drift. This is done in each case by using a fixed resistor for 91% of the resistance and a small pot to permit adjustment for the 9% drift. To ensure that the ability to compensate is always possible, the size of the pots is doubled. Gain is scaled with R_F and offset is zeroed with R_1 using the fixed and variable resistance values shown in Equations 6–9. The fixed resistors are selected to the nearest 1% values, and potentiometers to the next higher value:

$$R_{FA} = 0.91 \times R_F = 13.7 \text{ k}\Omega \text{ (1\% resistor)} \quad (6)$$

$$R_{FB} = 2 \times 0.09 \times R_F = 5 \text{ k}\Omega \text{ (Cermet potentiometer)} \quad (7)$$

$$R_{1A} = 0.91 \times R_1 = 3.65 \text{ k}\Omega \text{ (1\% resistor)} \quad (8)$$

$$R_{1B} = 2 \times 0.09 \times R_1 = 1 \text{ k}\Omega \text{ (Cermet potentiometer)} \quad (9)$$

Short-life applications

If the design life of the circuit is significantly shorter than the theoretical end-of-life of the devices, the tolerances of the devices themselves ($\pm 1\%$) can be used for the calculations. The reference diode, temperature sensor, and op amp will drift less as well. Allow 2% for errors not caused by resistors for a maximum total possible drift of $\pm 4\%$ (1% + 1% + 2%). Again, if gain is adjusted with R_F and offset with R_1 , values for the new resistors and potentiometers can be calculated with Equations 10–13, where fixed resistors have been selected for the nearest 1% values, and the potentiometers for the next higher value:

$$R_{FA} = 0.96 \times R_F = 14.3 \text{ k}\Omega \text{ (1\% resistor selection)} \quad (10)$$

$$R_{FB} = 2 \times 0.04 \times R_F = 2 \text{ k}\Omega \text{ (Cermet potentiometer)} \quad (11)$$

$$R_{1A} = 0.96 \times R_1 = 3.92 \text{ k}\Omega \text{ (1\% resistor selection)} \quad (12)$$

$$R_{1B} = 2 \times 0.04 \times R_1 = 500 \Omega \text{ (Cermet potentiometer)} \quad (13)$$

Calibration

To calibrate the circuit, a resistance decade box (or individual resistors or potentiometers) is connected in place of the thermistor. This calibration device is adjusted to the resistance corresponding to various temperatures. Calibration is done by adjusting first the gain and then the reference voltage. There is some interaction between these adjustments. Because both the lowest (0°C) and highest (100°C) temperatures in the range coincide with the power rail, the adjustments should be made at 5°C and 95°C. Linearity can be checked at 25°C, 50°C, and 75°C. Repeating this sequence provides verification of the calibration's precision.

Signal filtering

When a transducer is connected to an input, the wiring is subjected to noise signals because of the electrical and magnetic environment surrounding the transducer and wiring. To prevent this noise from interfering with the desired signals, some shielding is necessary. Using a twisted pair from the transducer to the conversion circuit and

shielding this pair (grounding the shield only at the instrument) will reduce the noise.

Without an input filter, the op amp will act as a radio frequency detector, converting high-frequency signals from other devices into signals with low-frequency components. Placing a resistor and capacitor on the input forms a low-pass filter, preventing high-frequency signals from interfering with the temperature signal. The cutoff frequency of this filter is defined by

$$F_C = \frac{1}{2\pi RC} \quad (14)$$

Using Equation 14, we know that if R_2 is 10 k Ω and $C_1 = 10$ nF, then F_C is about 1600 Hz.

Resistor R_F and capacitor C_2 , connected from the output of U1b to its noninverting input, cause the circuit to act as a low-pass filter. The purpose of this filter is to remove any further noise generated by the components in this circuit and low enough in frequency to get past the previous filter. An additional purpose is to remove any frequency near or above the sampling frequency of the ADC that will cause alias signals. The frequency response of this filter is also defined by Equation 14 to be 1060 Hz.

Decoupling

Power-supply decoupling is required to prevent the noise from the power supply from being coupled into the signal being amplified, and vice versa. This is accomplished using a 6.8- μ F tantalum in parallel with a 100-nF ceramic capacitor on the supply rails. The tantalum capacitor may be shared between multiple packages, but one ceramic capacitor should be connected as close as possible (preferably within 0.1 inch) to each package.

References

For more information related to this article, you can download an Acrobat Reader file at www-s.ti.com/sc/techlit/litnumber and replace "litnumber" with the **TI Lit. #** for the materials listed below.

Document Title	TI Lit. #
1. "Understanding Basic Analog—Ideal Op Amps," Application Report	slaa068
2. "Single Supply Op Amp Design Techniques," Application Report	sloa030
3. "Active Low Pass Filter Design," Application Report	sloa049
4. "Application of Rail-To-Rail Operational Amplifiers," Application Report	sloa039
5. Ron Mancini, "Sensor to ADC—analog interface design," <i>Analog Applications Journal</i> (May 2000), pp. 22-25	slyt015

Related Web sites

www.rtie.rti-corp.com/accurv.htm

www.alphasensors.com/interchange.html

www.ti.com/sc/docs/products/analog/tlv2472a.html

www.ti.com/sc/docs/products/analog/tlv2544.html

For a complete op amp application index, see:

www.ti.com/sc/docs/apps/analog/operational_amplifiers.html

Appendix A. Calculations

The following summary shows values and equations used in this application note. Values in bold are calculated. All entered values are non-bold.

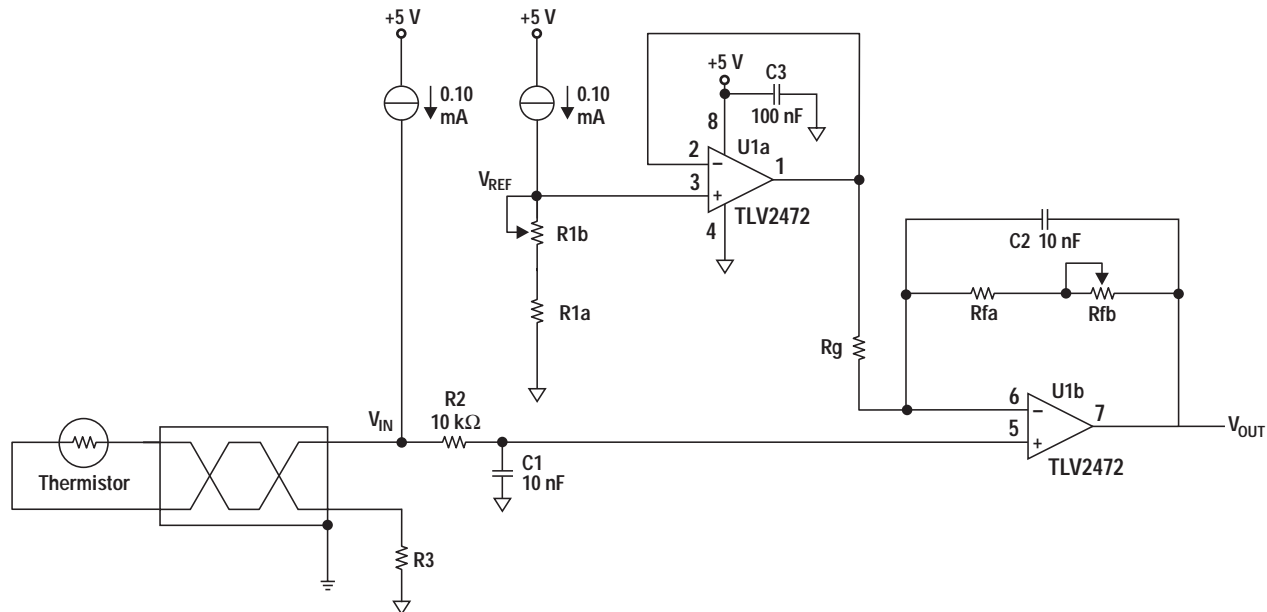

Given:

$$R_{0^{\circ}\text{C}} = 32650.0 \text{ ohms}$$

$$R_{100^{\circ}\text{C}} = 678.3 \text{ ohms}$$

$$I_{\text{SENSOR}} = 100.0 \mu\text{A}$$

$$V_{0^{\circ}\text{C}} = 3.26500 \text{ V}$$

$$V_{100^{\circ}\text{C}} = 0.06783 \text{ V} \quad \mathbf{1\%}$$

$$R_3 = 3000 \quad \mathbf{3010 \text{ ohms}}$$

$$\text{Output}_{\text{MAX}} = 5 \text{ V}$$

$$\text{Output}_{\text{MIN}} = 0 \text{ V}$$

$$V_{R3} = 0.301 \text{ V}$$

$$m = \frac{\text{Output}_{\text{MAX}} - \text{Output}_{\text{MIN}}}{(R_{0^{\circ}\text{C}} - R_{100^{\circ}\text{C}}) I_{\text{SENSOR}}}$$

$$m = 1.564$$

Resistor values:

$$m = R_F/R_G + 1$$

$$R_F = (m - 1)R_G$$

$$R_F = 5.944R_G$$

Gain resistor values:

$$R_G = 27000 \quad \mathbf{26700 \text{ ohms}}$$

$$R_F = 15055.68 \quad \mathbf{15000 \text{ ohms}}$$

$$\text{At } 100^{\circ}\text{C:} \quad \frac{V_{\text{REF}} - V_{R3} - \text{Output}_{\text{MIN}}}{R_{100^{\circ}\text{C}} \times I_{\text{SENSOR}}} = \frac{R_F + R_G}{R_G}$$

$$V_{\text{REF}} = 0.40594 \text{ V}$$

$$R_1 = V_{\text{REF}}/I_{\text{SENSOR}}$$

$$R_1 = 4059 \quad \mathbf{4020 \text{ ohms}}$$

End-of-life adjustment calculations

$$R_{1A} = 3694.0 \quad \mathbf{3650 \text{ ohms}}$$

$$R_{1B} = 730.7 \quad \mathbf{1000 \text{ ohms}}$$

$$R_{FA} = 13650 \quad \mathbf{13700 \text{ ohms}}$$

$$R_{FB} = 2700 \quad \mathbf{5000 \text{ ohms}}$$

Expendable adjustment calculations

$$R_{1A} = 3897 \quad \mathbf{3920 \text{ ohms}}$$

$$R_{1B} = 324.7 \quad \mathbf{500 \text{ ohms}}$$

$$R_{FA} = 14400 \quad \mathbf{14300 \text{ ohms}}$$

$$R_{FB} = 1200 \quad \mathbf{2000 \text{ ohms}}$$

$$C = 0.01 \mu\text{F}$$

$$F_{\text{IN}} = 1/(2\pi R_1 C) = 1592 \text{ Hz}$$

$$F_{\text{Amp}} = 1/(2\pi R_F C) = 1061 \text{ Hz}$$