

Wavelength Division Multiplexing (WDM) is a technique, which uses a special property of fiber-optics. This property allows the combination of multiple signals onto a single strand of fiber. Each signal is assigned to a different wavelength, of light. Since one wavelength does not affect another wavelength, the signals do not interfere.



Figure 1: typical application of a 1310/1550-nm WDM

Coarse WDMs perform two functions. First, they filter the light, ensuring only the desired wavelengths are used. Second, they multiplex or demultiplex multiple wavelengths, which are used on a single fiber link (see Figures 2a & 2b). The difference lies in the wavelengths, which are used. In CWDM space, the 1310-band and the 1550-band are divided into smaller bands, each only 20-nm wide. In the multiplex operation, the multiple wavelength bands are combined (i.e. *muxed*) onto a single fiber. In a demultiplex operation, the multiple wavelength bands are separated (i.e. *demuxed*) from a single fiber. The used wavelengths are defined by the International Telecommunications Union; reference ITU G.694.2 for the ITU CWDM Wavelength Grid. Note: as of June 2002, eighteen center wavelengths, from 1270 nm to 1610 nm, were listed.

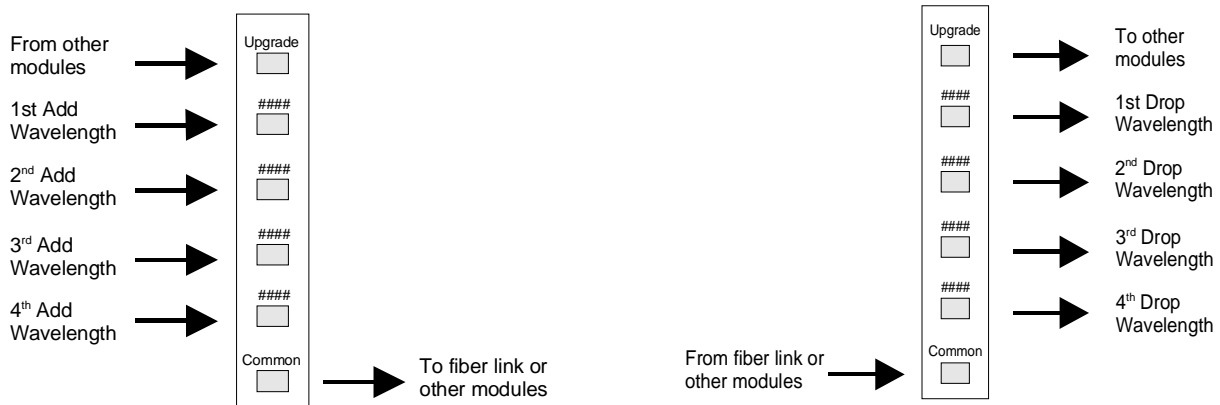

Figure 2: (a) Using Multiplexer (Mux) and (b) using a Demultiplexer (Demux)

In a hybrid configuration (mux/demux), multiple transmit and receive signals can be combined onto a single fiber. Each signal is assigned a different wavelength. At each end, transmit signals are muxed, while receive signals are demuxed. For example, in a simple full-duplex link, the transmit is assigned the 1530-nm wavelength, while the

receive signal is assigned the 1550-nm wavelength.

Additionally, individual signals can be delivered at points along a link. A receive signal is demuxed (i.e. *dropped*) from the link, and a new transmit signal is muxed (i.e. *added*) onto the link. This application is called an Add/Drop module (see Figure 3).

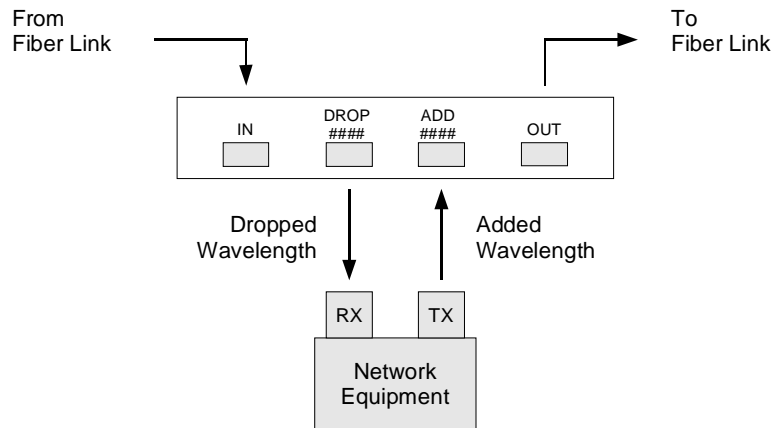

Figure 3: Using an Add/Drop CWDM Module

Generally, a CWDM network takes two forms. A point-to-point system connects two locations, muxing and demuxing multiple signals on a single fiber (see Figure 4). A loop or multi-point system connects multiple locations, typically using Add/Drop modules (see Figure 5).

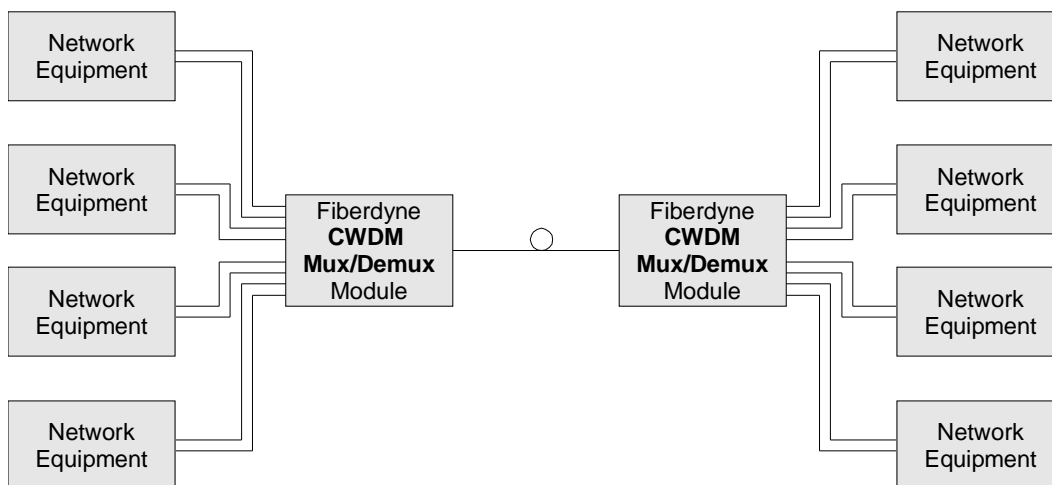

Figure 4: Point-to-point Multiplexer Network

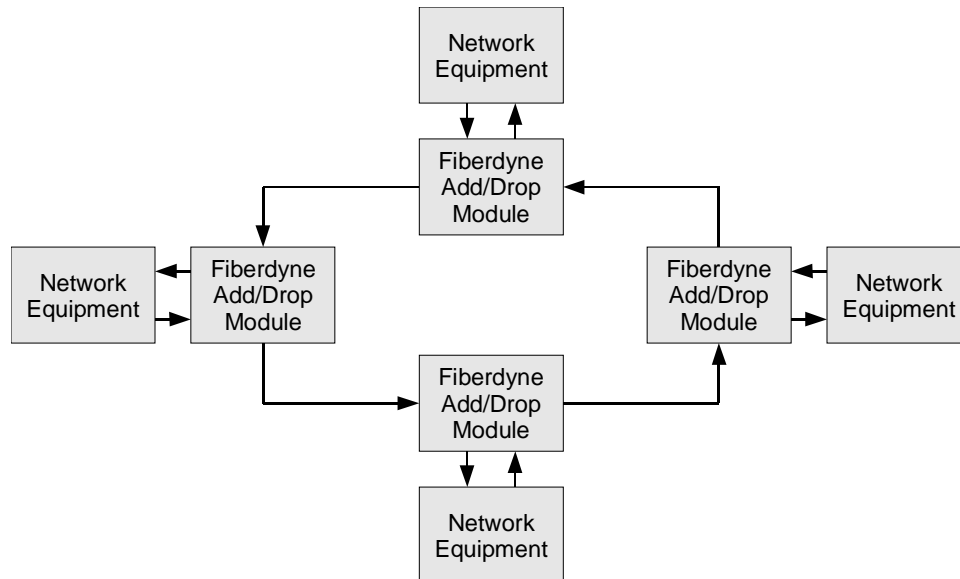

Figure 5: Add/Drop Loop Multiplexer Network

Using Fiberdyne equipment, you can use two implementations. In one approach (see Figure 6), Fiberdyne CWDM GBICs (Gigabit Interface Converters) are added to existing Ethernet switch equipment. The GBIC outputs feed Fiberdyne, CWDM modules. The other approach (see Figure 7) adds the Fiberdyne 3001 CWDM Optical Multiplexer System to the existing outputs of existing Ethernet switch equipment.

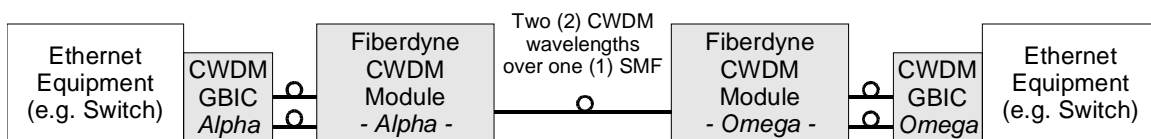

Figure 6: Multiplexing with Fiberdyne CWDM GBICs and CWDM Modules

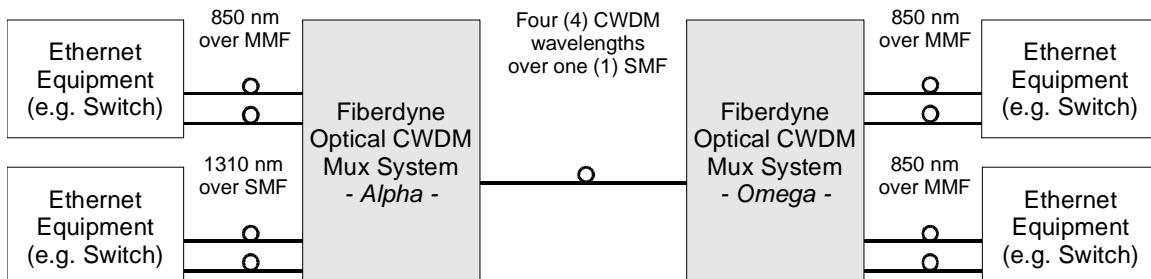

Figure 7: Multiplexing with Fiberdyne 3001 CWDM Optical Mux System Modules