



MS Kennedy Corporation

DC-DC Converters

Transform
Isolate
Regulate



LINEAR POWER DELIVERY

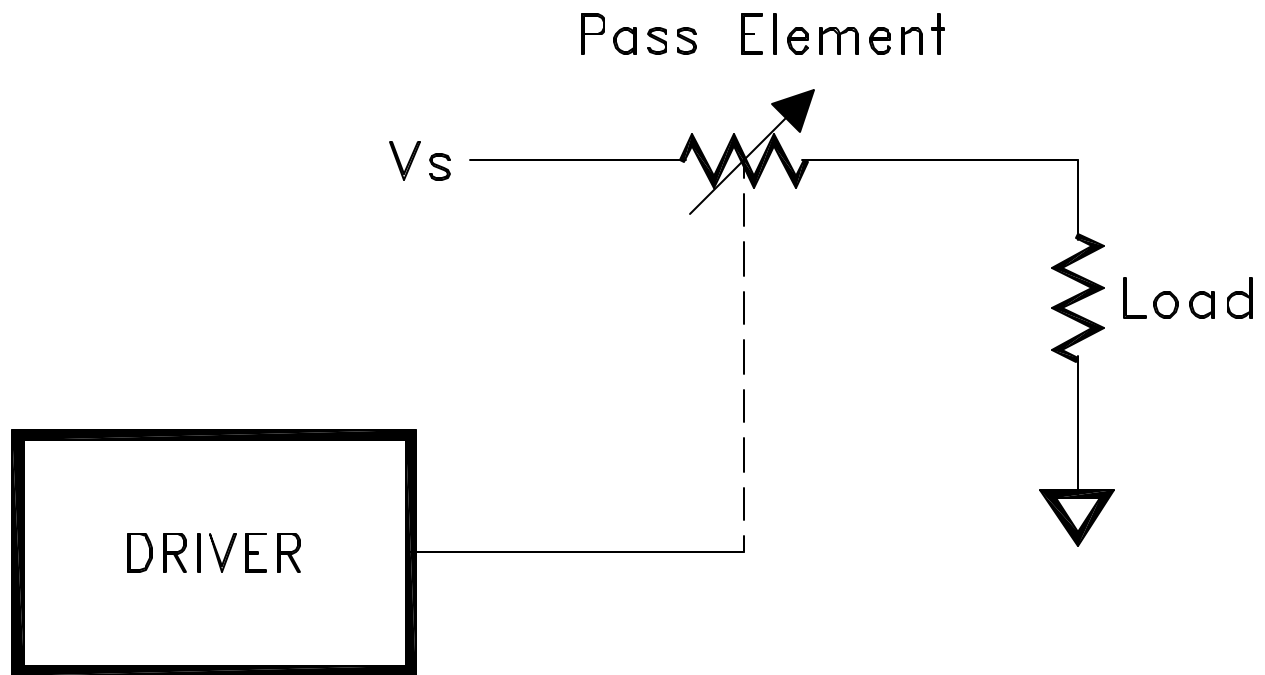

The most popular DC-DC converter application vividly demonstrates why the DC-DC converter is the only reasonable choice compared to a linear regulator. This function is providing 5V for logic or computer circuits from a 28V bus.

Let us assume the load requires 1A @ 5V or 5W. A linear regulator would pass the 1A while having 23V across it, thus wasting 23W. With an input power of 28W, efficiency is less than 18%! Unless the application also just happens to need a 23W heater, you pay twice; once to generate the 23W and again to get rid of it. Typical efficiencies of these DC-DC converters reduce this waste heat by better than an order of magnitude.

PWM POWER DELIVERY

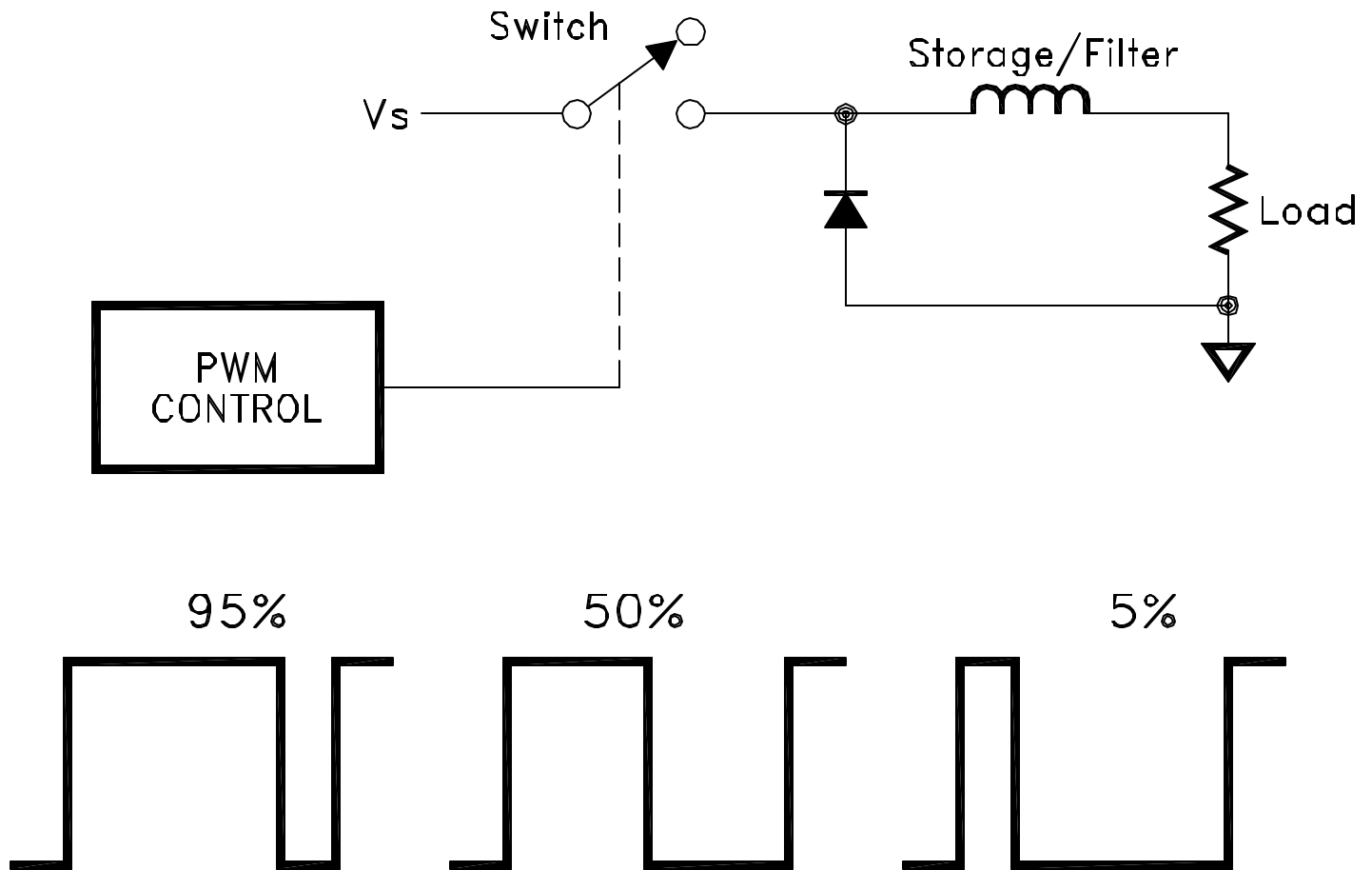

These figures illustrate the most basic PWM operation. The PWM control block converts the DC input into a variable duty cycle switched drive signal. If high output is commanded, the switch is held on most of the period. When the switch is on, losses are simply a factor of the on resistance of the switch plus the inductor resistance. As less output is commanded the duty cycle or percent of on time is reduced. When the switch is off, losses now include heat generated in the flyback diode. At most practical supply voltages this diode loss is still small because the diode conducts only a portion of the time, and voltage drop is a small fraction of the supply voltage.

The job of the inductor is both storing energy and filtering. In this manner the load sees very little of the switching frequency, but responds to the regulator loop whose frequencies are significantly below the switching frequency.

DC-DC Basic Block Diagram

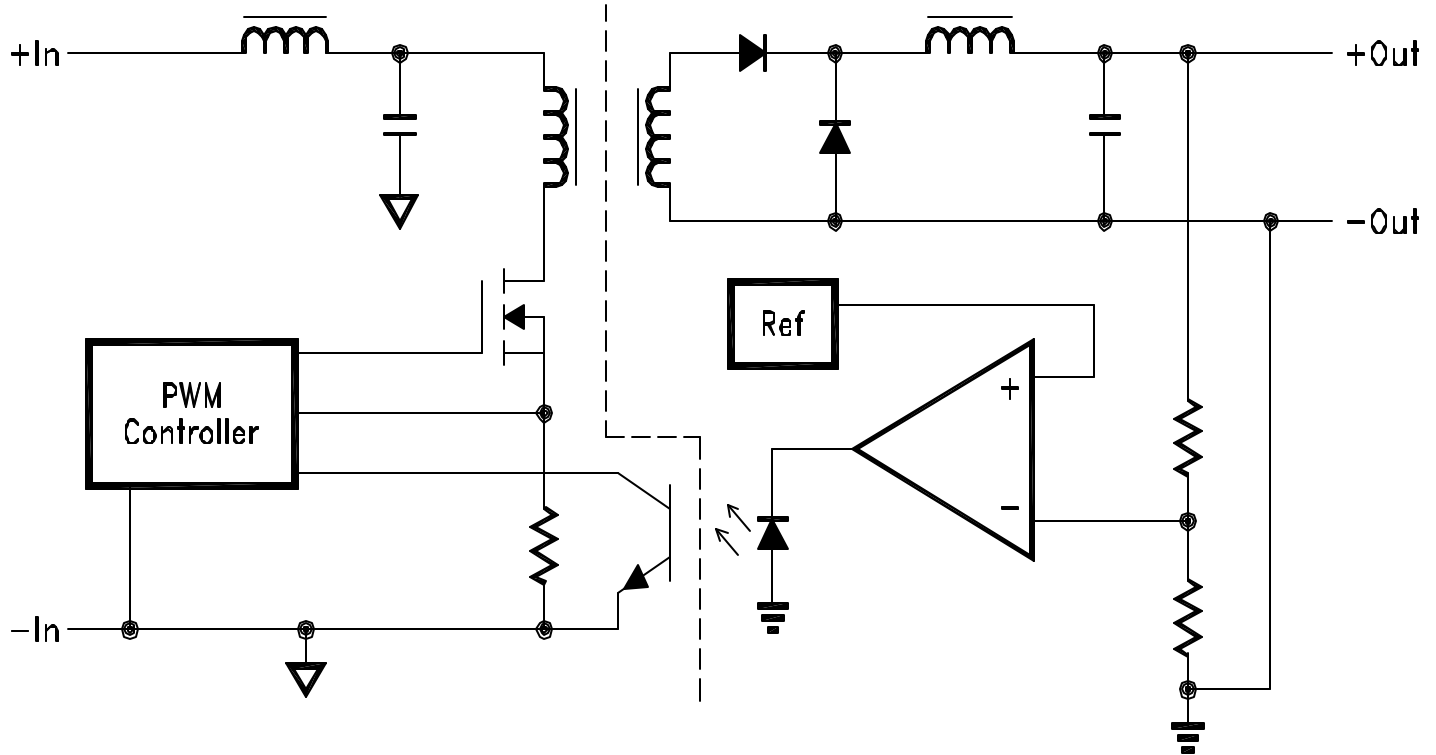

The basic blocks of the DC-DC converter consist of input and output filters, the PWM controller, a reference, an error amplifier, power isolation with rectification and error feedback isolation. The input filter reduces the effect of internal current pulses on the supply bus. Depending on the application, additional external filtering may be required. The output filter keeps most of the voltage pulses inside the converter. The need for dedicated external filter components right at the converter is unusual because there are almost always supply bypass capacitors local to the powered circuitry.

The error amplifier integrates the difference between the output voltage and the reference voltage and signals the PWM controller to lengthen the pulse if the output is low or shorten the pulse if the output is high. This example shows optical isolation of the feedback signal. The optical technique requires fewer parts but great care must be taken in the design of the dynamic range to avoid saturation or starvation over temperature and operating life.

Note that this diagram uses two types of “ground” symbols, but an isolation barrier separates each type. Although cluttered, it would have been more correct to draw this diagram without ground symbols at all. Each half of this device is a floating two terminal circuit where either terminal could be “grounded” to local external circuits. It would be possible to operate on a negative input voltage or to output a negative voltage.

Pulse Width Extremes

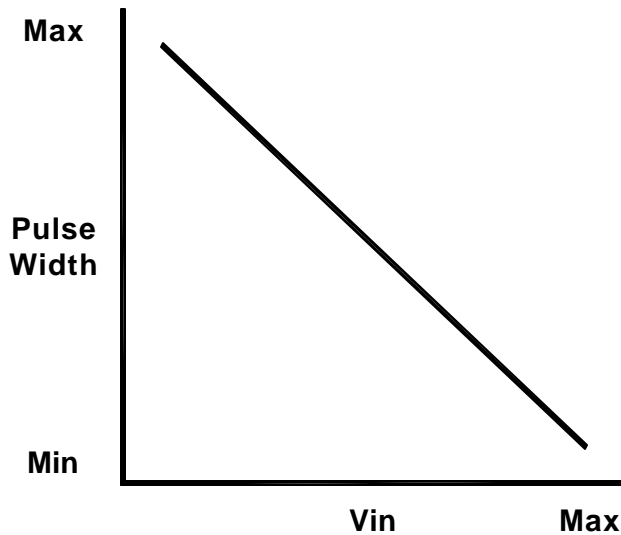

Longest
Min Vin & Max Iout

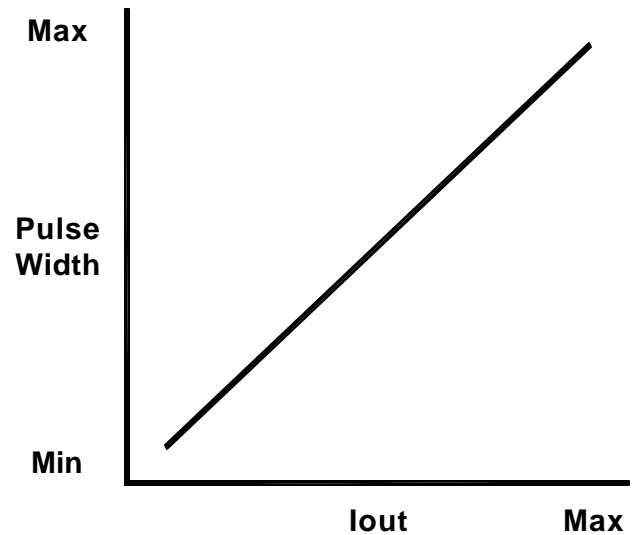

Shortest
Min Vin & Max Iout

The challenge of setting up the pulse width modulator is to get enough dynamic range to deliver the specified output (while maintaining regulation) even though three variables are moving over wide ranges. The three variables that affect the pulse width are: input voltage, output current and internal losses due to temperature variations.

If output current remains constant, the average energy into the filter inductor must remain constant. As input voltage rises, the energy delivered to the inductor in a given time increases. Since inductor current is proportional to time, the controller must shorten the pulse width to close the regulation loop.

If the input voltage is constant but output current decreases, less energy must be delivered to the inductor. Again, the controller must shorten the pulse width to achieve this.

Even if input and output are rock solid, there are changes of internal losses due to temperature variations. FET on resistance, diode forward drops, copper losses, and core losses are the main factors changing over temperature. Even though some of these tend to cancel, losses typically increase a little at -55°C and increase even more at $+125^{\circ}\text{C}$. Either case calls for increasing the pulse width to maintain regulation.

MSK DC-DC Converters

- 28V input
- Hi-Rel design and construction
- No derating over specified temperature
- Fault tolerant with fault flag
- 500V isolation
- 100% temperature tested mil versions
- Programmable Vstart and remote S/D
- Hermetic packages
- Available to DSCC smds

The classic 28V bus is usually anything but 28V. That's why the high-to-low input range of MSK converters spans 2.5:1 to over 4.5:1. Transient protection levels go even higher than that.

While some manufacturers rate the wattage of their converters within a moderate temperature range with no mention of derating at higher temperatures, this is not true with MSK. The converters will deliver full power over the entire temperature range listed in the data sheet. Many MSK models are rated for full power over the full military temperature range of -55°C to +125°C.

MSK military grade converters are not merely characterized over temperature, but are 100% temperature tested.

Upon a Shorted Output you would:

- A. Run hot with current $> 100\%$
- or
- B. Run cool with low duty cycle

With power devices, deciding what to do about the dreaded short circuit on the output is always interesting. Does the space and the cooling capacity exist to simply set a current limit safely above the required output power level and let the unit run hot? While quite rare, there are a few applications where a load fault is so unlikely that no safety provisions are required for the power stage.

With low duty cycle fault response, MSK DC-DC converters bring a new level of confidence. Watching the input current to a converter driving near full load will show the fault response when it's time to run the load fault test. The current meter will actually drop. The first time this is seen, it looks wrong. But it isn't wrong, it's low duty cycle fault response at work.

Low Duty Cycle Fault Response

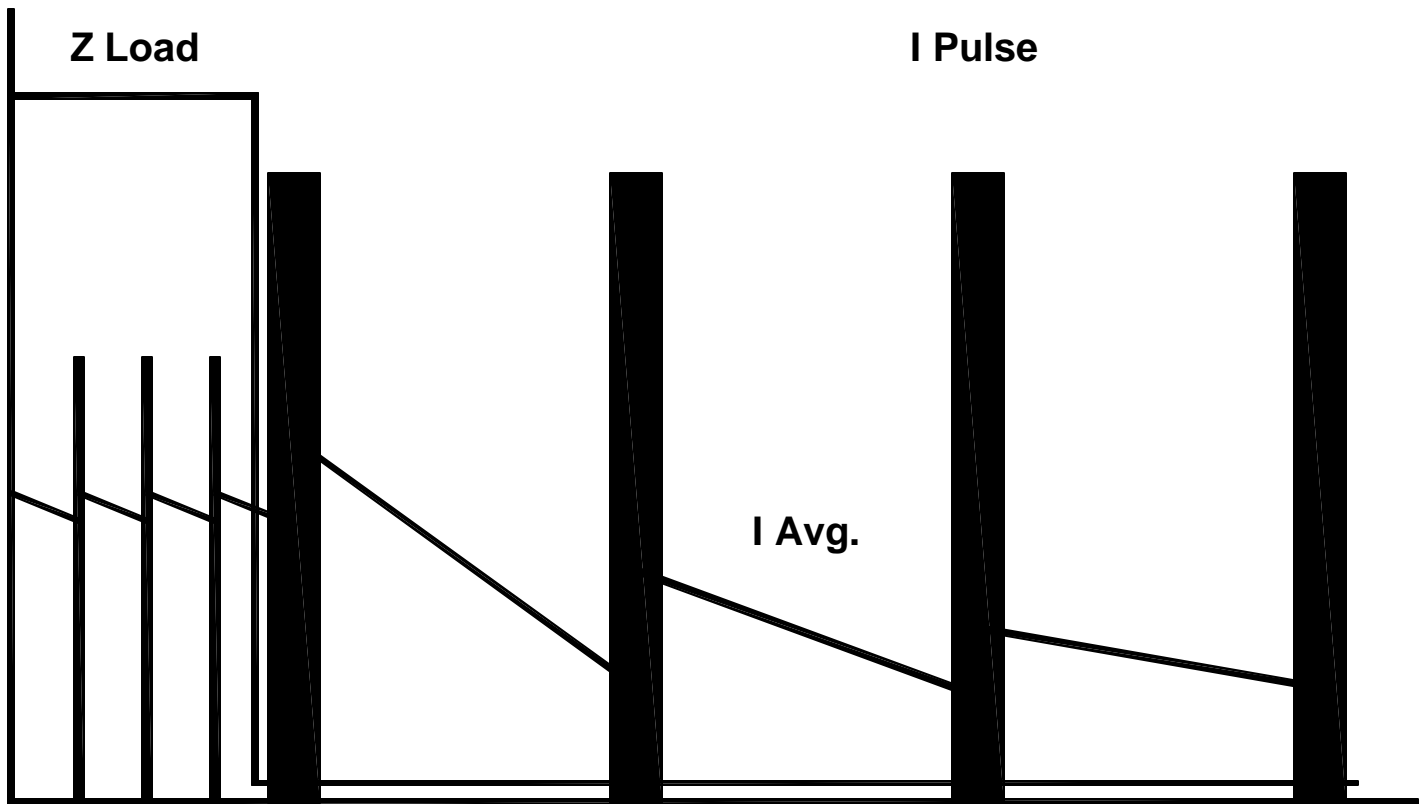

With a normal load impedance corresponding to a near full load, moderate width pulses and the average current are as expected for the efficiency of the converter. While it is not graphed, the error feedback signal is also at a moderate level.

When the load impedance plunges to zero or near zero, the error feedback signal swings to its maximum. It actually calls for a pulse width longer than the controller is capable of producing. The low duty cycle circuit picks up on this allowing one pulse out, but then it puts the converter to sleep for about 10 times the maximum pulse width. Even though internal heat generation during this big pulse is higher than before the fault condition, reducing the duty cycle to about 10% makes the average heat generation less than when running at full load. This low average power mode of operation is continued as long as the fault is present. Normal operation resumes when the fault is cleared.

CERAMIC CAPS ONLY

- Improved hi-temp reliability
- Improved time and temperature stability
- Smaller values than tantalum/electrolytic
- Added application flexibility

Electrolytic and tantalum capacitors are known to excel at packing lots of capacitance in a small space. However, there are trade-offs. MSK designers kept high reliability as their prime design goal while making component selections.

Electrolytic and especially tantalum capacitors simply can't match the reliable performance of ceramic in the full military temperature range. Ceramic capacitors exhibit a lower temperature coefficient and are more stable over time. This makes temperature characterization of your circuit easier because the dynamic performance of the converter is more stable over temperature. Ceramic capacitors however, can't meet the volumetric efficiencies of electrolytic or tantalum types, so capacitor values are limited to fit in the hybrid package. It turns out though that these smaller values yield flexibility akin to an op amp featuring external compensation. Dynamic or transient performance can be tailored to fit the application.

Response Curves vs. Capacitance

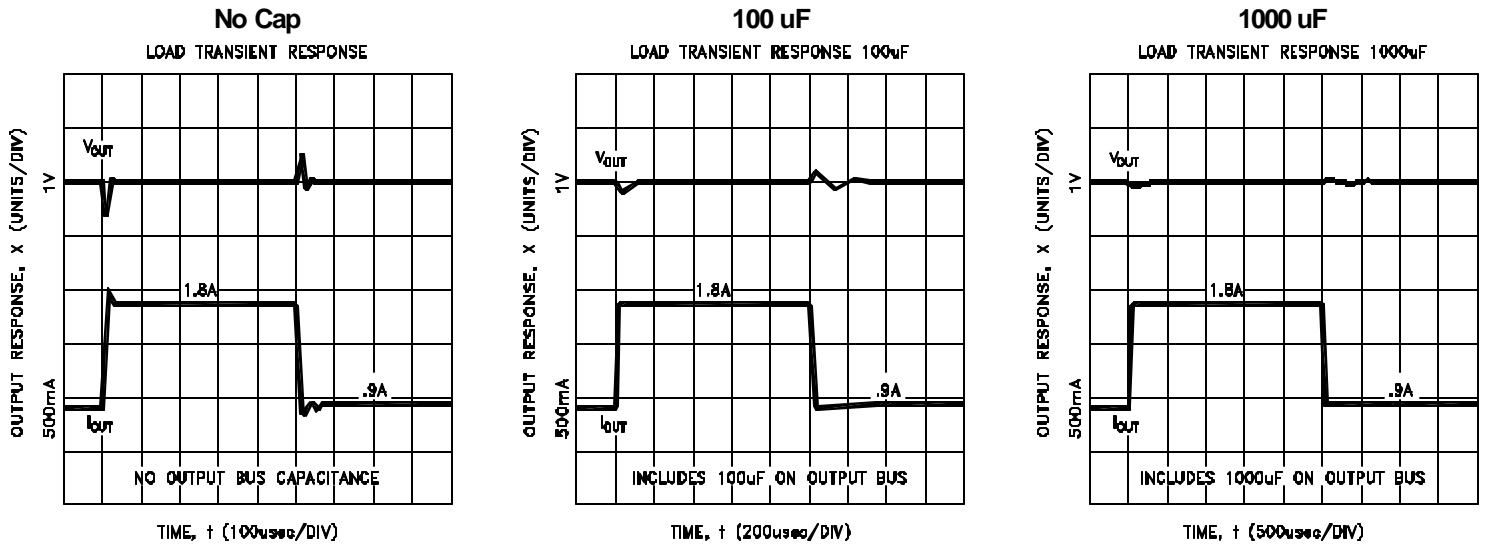

DHC2803S Load Transient Response Curves

There are choices to be made. Is the application fast and sensitive to 0.75 peak deviations from 3.3V? Or is it a slower system which is more sensitive to longer term 10mV deviations; maybe where the 3.3V is used as an analog reference?

Please note the time scale changes between the graphs. In applications where the output is used as an analog reference voltage, using no external capacitor may be possible. Settling time in this graph is under 100 μ s. Even though the peak deviation is high, a system running at 100 Hz will likely never see the short transient.

For faster systems, the use of an external capacitor will greatly reduce the peak deviation, but with a settling time in the millisecond range.

Shutdown+ Pin

- Shutdown with an open collector
- Program Vstart with a resistor
- Monitor faults with a J-FET

MSK converters offer some control over turn-on sequencing of your system. The Shutdown+ pin has three functions which can be used in all combinations. The first function is that of programming a low voltage start-up point. Installing only one resistor to ground will set the level according to:

$$R = 210 \text{ K}/(V_{\text{start}}-9.5)$$

This means with an open or several hundred Kohms, start-up is about 9.5V. The 9.5V level is increased by 210 K/R, so 21 Kohms yields about 19.5V start-up.

The second function is really a digital over-ride of the analog function above. Use an open collector transistor to ground the pin and the function now becomes a remote shutdown.

The Shutdown+ pin is also an output function: A load fault condition will cause a negative pulse on the pin from above 10V to below 1V for around 100 ms for each power pulse in the low duty cycle fault response mode of operation.

DHC/DAC/DHD2800S Series

DHC2803S	12-50V	5W	1.52A
	13-50V	6W	1.82A
DHC2805S	12-50V	6W	1.2A
DAC2812S	11-50V	5W	0.417A
	16-40V	5.4W	0.45A
DAC2815S	11-50V	5W	0.333A
	16-40V	5.4W	0.36A
DHD2805S	16-40	7.5W	1.5A

This is the smallest series of converters from MSK (electrically and mechanically). They fit in an industry standard footprint with the exception that a NC pin is used to implement the Adjust/Comp function. If an existing application makes no connection to the NC pin, the DHC2800, DAC2800, DHD2800 series will drop in.

The DHC2803S can be extended to 6W if minimum input is raised to 13V.

All DHC, DAC & DHD converters will provide greater power with a slightly higher minimum input voltage. This will lower the overall efficiency, but up to 7.5W may be achieved.

DHC2800S/DHD2800S Special Features

- MHE2800/ASA2800 Compatible
- -55°C to +125°C temperature range
- Mil-Std-704 (80V survive only)
 - DHD2805S operates thru 80V
- +/-10% Adjust range
- 1 inch square package
- Available to DSCC smds

The MSK line of 6 and 7 watt converters provide pin compatible drop in replacement or a second source for existing applications. These units provide increased performance over the industry standard offerings.

DHC2800S Block Diagram

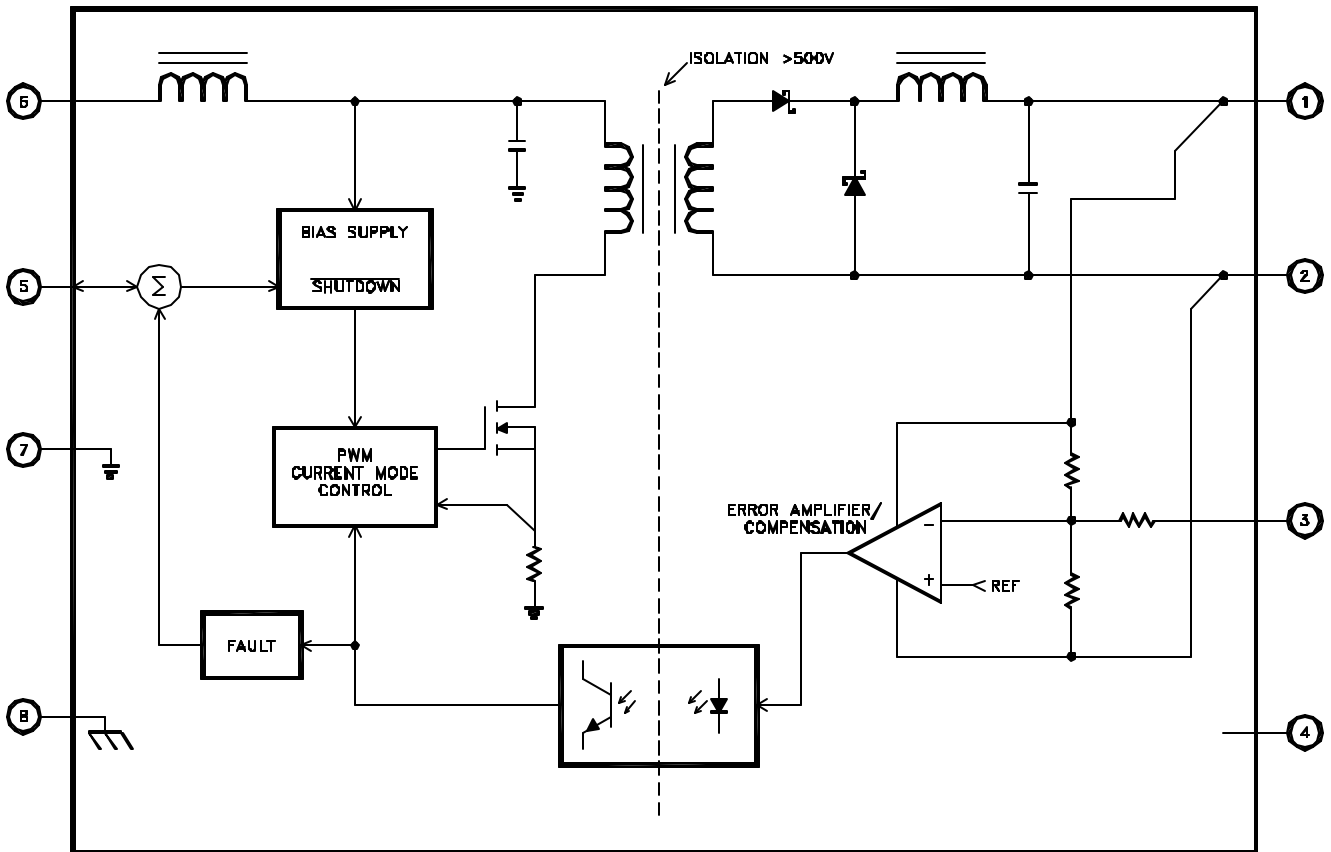

MSK DHC and DAC converters feature a transformer isolated feed forward topology operating at 400 KHz to allow an extremely wide input voltage range.

Voltage adjustment is also possible with these converters with an external connection through a resistor to the summing junction of the error amplifier. These models are also offered with no connection to this pin.

DAC2800S Block Diagram

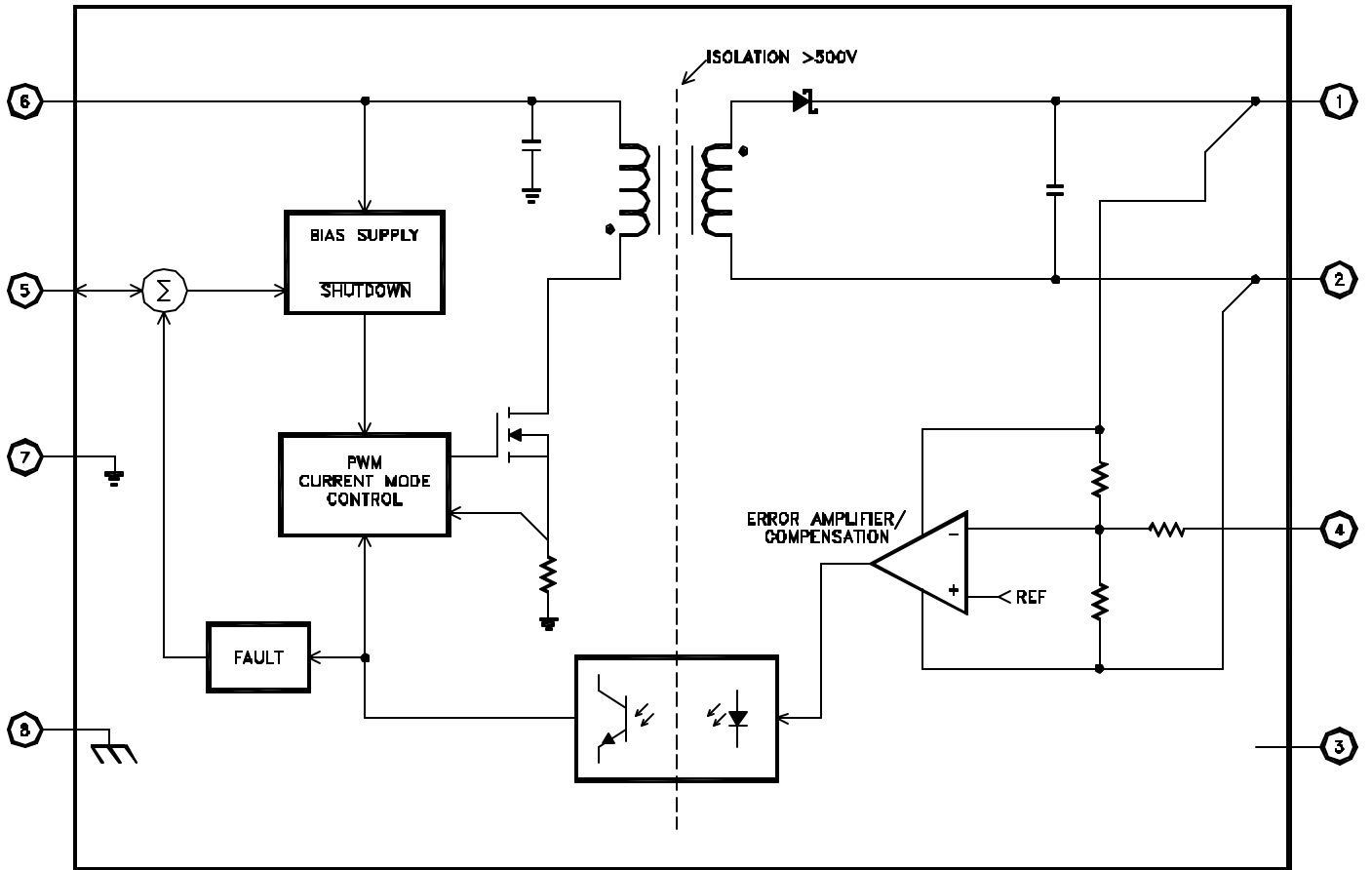

DAC2800D Series

			Balanced	Unbalanced
DAC2812D	11-50V	5W	±0.208A	0.333A
	16-40V	5.4W	±0.225A	0.36A
DAC2815D	11-50V	5W	±0.167A	0.267A
	16-40V	5.4W	±0.18A	0.288A

Again, this is the smallest series of converters from MSK (electrically and mechanically). They fit in an industry standard footprint with the exception that a NC pin is used to implement the Adjust/Comp function. If an existing application makes no connection to the NC pin, the DHC2800D series will drop in. These models are also available with the NC option.

The current ratings labeled “±” are for balanced load currents on both the positive and the negative sides. The “Unbal” column indicates the maximum current for one of the two outputs. The other output may then supply the remaining available current bringing total delivered watts up to the converter rating. As an example the DAC2812D running on 32V can be loaded to 0.36A on one side and 0.09A on the other side. To maintain regulation, the lighter load must draw at least 20% of the total power regardless of the total watts.

DAC2800D Special Features

- MHE2800/ASA2800 Compatible
- -55°C to +125°C temperature range
- Dual Tracking Regulation
- Mil-Std-704 (80V survive only)
- +/-10% Adjust range
- 1 inch square package

The DAC2800D Series offers a positive and negative output with a common output ground. This offers the user dual voltages that will track together thermally and through line and load regulation.

DAC2800D Block Diagram

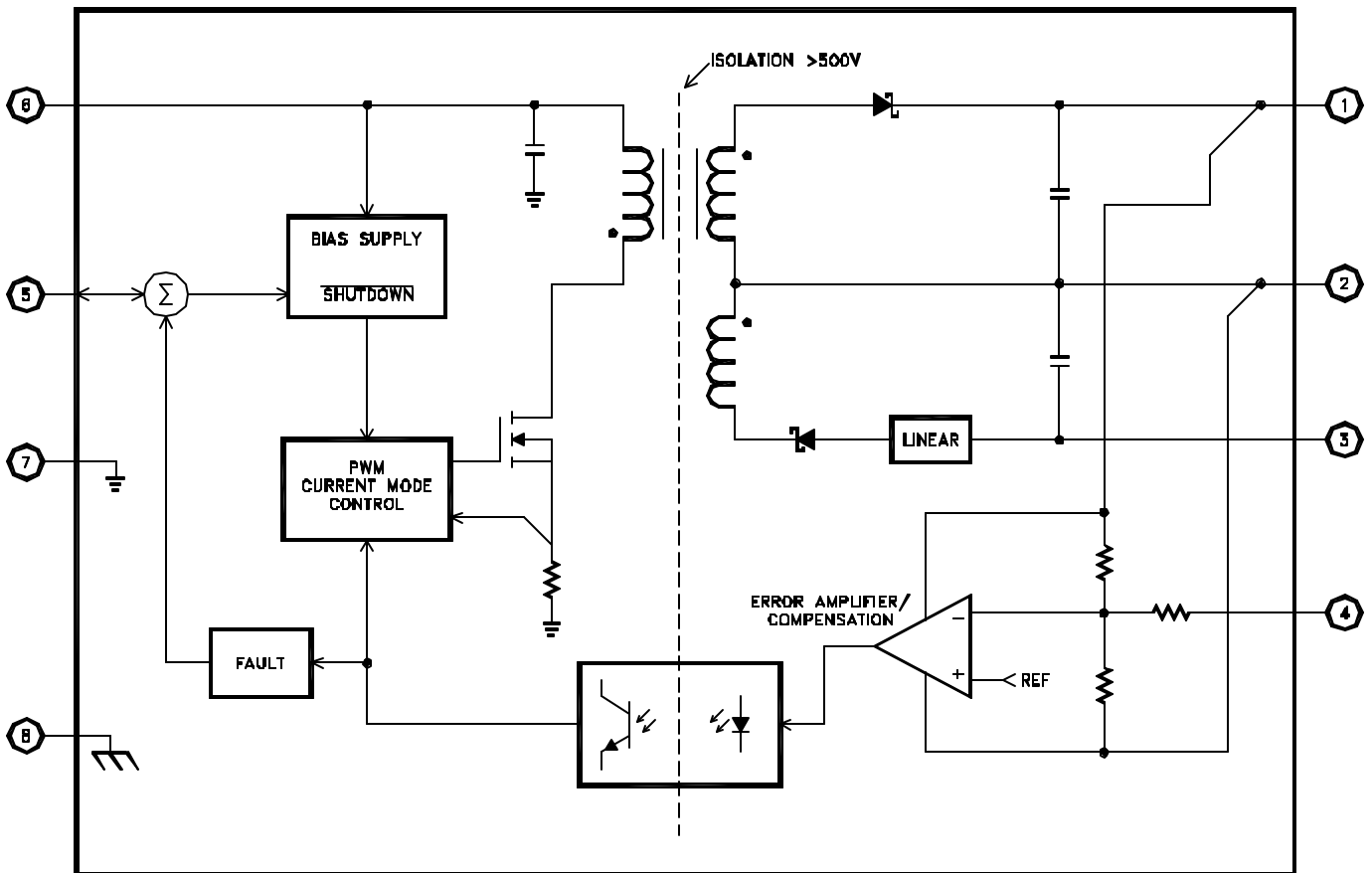

The input section of these dual converters is the same as the input of the single output converters. On the output section, note the top transformer winding along with the lower op amp form a regulated positive output in a similar fashion to the single converter.

The lower transformer winding is the heart of the negative output. In the middle we have the unique feature of the DAC duals: the second op amp and the power MOSFET provide tracking regulation for the negative output.

BBF2800S Series

BBF2803S 3.3V 18W 5.5A

BBF2805S 5V 20W 4A

BBF2812S 12V 23W 1.9A

BBF2815S 15V 22W 1.5A

This series of converters from MSK takes a jump in electrical and mechanical size. The extremely rugged package was utilized by MSK to meet high power requirements. Total footprint area is 3 square inches and the pins are dual-in-line.

BBF2800S Special Features

- Kelvin remote sensing
- 16 to 40V Input range
- -55°C to 125°C temperature range
- Mil-Std-704D (80V survive only)
- +/-10% Adjust range
- Rugged package
- Synchronize up to 3 units directly

The MSK BBF Series provides high performance in a unique package. Users may take advantage of the many special features this converter has to offer.

BBF2800S Block Diagram

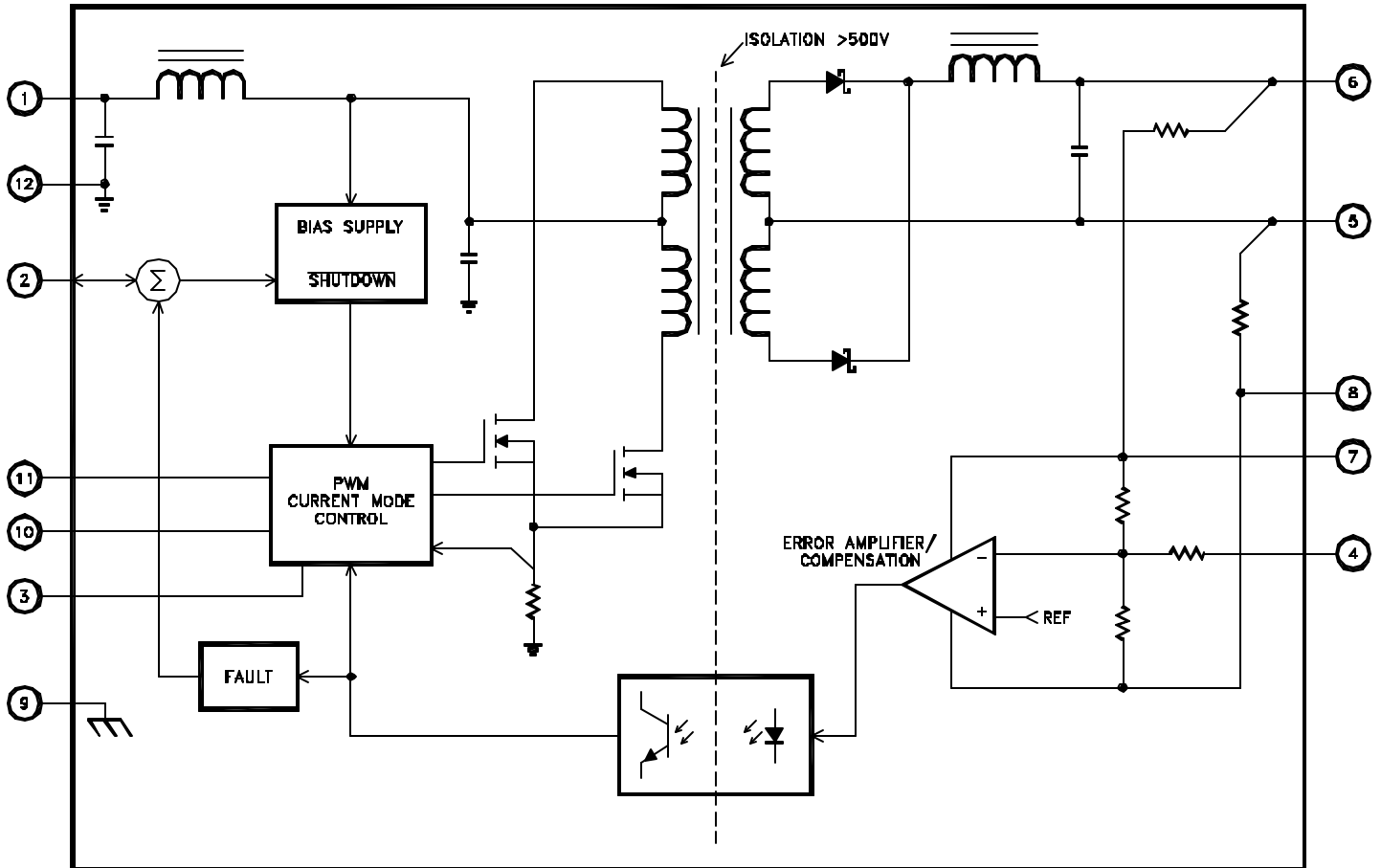

The BBF converters feature a current mode push-pull topology operating at 500 KHz. The larger 12 pin package allows better filtering, Kelvin sensing, synchronization and output voltage adjustment.