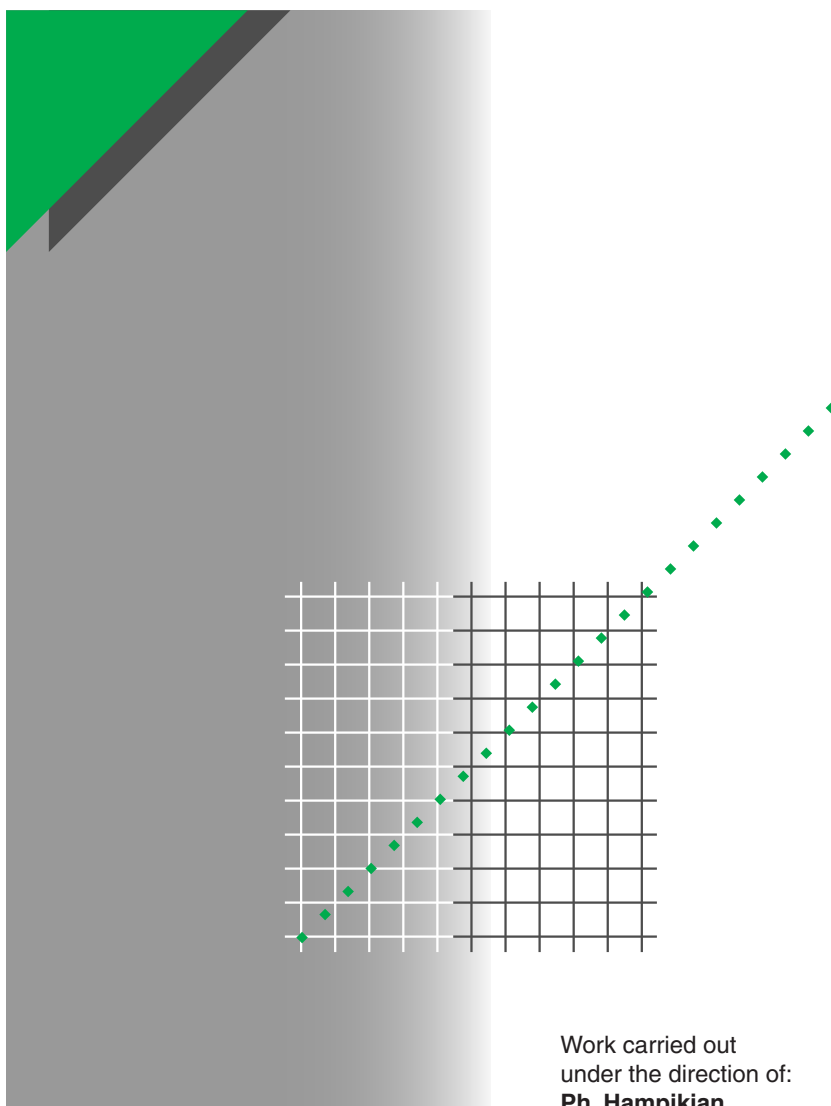


Cahier technique no. 209

Data acquisition: Detection



"Cahiers Techniques" is a collection of documents intended for engineers and technicians, people in the industry who are looking for more in-depth information in order to complement that given in product catalogues.

Furthermore, these "Cahiers Techniques" are often considered as helpful "tools" for training courses.

They provide knowledge on new technical and technological developments in the electrotechnical field and electronics. They also provide better understanding of various phenomena observed in electrical installations, systems and equipments.

Each "Cahier Technique" provides an in-depth study of a precise subject in the fields of electrical networks, protection devices, monitoring and control and industrial automation systems.

The latest publications can be downloaded from the Schneider Electric internet web site.

Code: <http://www.schneider-electric.com>

Section: **Press**

Please contact your Schneider Electric representative if you want either a "Cahier Technique" or the list of available titles.

The "Cahiers Techniques" collection is part of the Schneider Electric's "Collection technique".

Foreword

The author disclaims all responsibility subsequent to incorrect use of information or diagrams reproduced in this document, and cannot be held responsible for any errors or oversights, or for the consequences of using information and diagrams contained in this document.

Reproduction of all or part of a "Cahier Technique" is authorised with the compulsory mention:

"Extracted from Schneider Electric "Cahier Technique" no." (please specify).

no. 209

Data acquisition: Detection

This “Cahier Technique” is the work of a team of experts specializing in the various technologies featured herein:

Jean-Marie Cannoni

Electromechanical detection

Vincent Daniau

Vision - RFID (Radio Frequency Identification)

Patrice Delage

Ultrasonic detection, encoders

Christophe Delaitre

Pressure control

Pascal Launay

Inductive, capacitive, photoelectric sensors

In association with:

Alain Guillot

For a view on the future of presence detectors

The team was led by:

Philippe Hampikian

Industrial Presence Sensors Activity Manager

In an automated installation, all the information needed to control it must be detected in order to be managed by the control systems.

The “detection” function is therefore essential in all industrial processes, and a knowledge of the various techniques is vital to choose the right detectors: they have to be able to operate in sometimes difficult environments and supply information that is compatible with the acquisition and processing systems.

This document is aimed at those wanting to familiarize themselves with the field of Detection in Industrial Automation.

After setting out the broad technical background to this field, each technology is analyzed in detail to provide a basic selection guide. This is complemented by an overview of related technologies, including Vision and RFID (Radio Frequency IDentification).

Detection may seem complicated at first, but you will soon learn that it is simply “varied”!

Happy reading!

Data acquisition: Detection

Contents

1 Introduction	1.1 Detection: A vital function	p. 4
	1.2 The various detection functions	p. 4
	1.3 The various detector technologies	p. 5
	1.4 Auxiliary detector functions	p. 5
2 Electromechanical limit switches	2.1 Detection movements	p. 6
	2.2 Contact operating mode	p. 6
3 Inductive proximity sensors	3.1 Principle	p. 8
	3.2 Description of an inductive sensor	p. 8
	3.3 Influence quantities in inductive sensing	p. 9
	3.4 Specific functions	p. 9
4 Capacitive proximity sensors	4.1 Principle	p. 10
	4.2 The various types of capacitive sensor	p. 11
	4.3 Influence quantities for a capacitive sensor	p. 11
5 Photoelectric sensors	5.1 Principle	p. 12
	5.2 The various detection systems	p. 12
	5.3 Influence quantities in detection using photoelectric systems	p. 16
6 Ultrasonic sensors	6.1 Principle	p. 17
	6.2 Application	p. 17
	6.3 Special features of ultrasonic sensors	p. 18
	6.4 Advantages of ultrasonic detection	p. 19
7 RFID detection (Radio Frequency IDentification)	7.1 Background	p. 20
	7.2 Operating principles	p. 20
	7.3 Description of the components	p. 21
	7.4 Advantages of RFID	p. 23
8 Vision	8.1 Principle	p. 24
	8.2 Key points in vision	p. 24
9 Optical encoders	9.1 Description of an optical encoder	p. 28
	9.2 Optical encoder families	p. 29
	9.3 Using an encoder with a processing unit	p. 32
10 Pressure switches and vacuum switches	10.1 What is pressure?	p. 33
	10.2 Pressure control sensors	p. 33
11 Other characteristics of presence detectors		p. 36
12 Conclusion		p. 37

1 Introduction

1.1 Detection: A vital function

The detection function is vital because it is the first link in the chain of information (see Fig. 1) for an industrial process.

In an automatic system, detectors collect information about:

- All the events that are needed to control it, so that they can be taken into account by the control systems, using an established program
- The progress of the various stages of the process when this program is executed

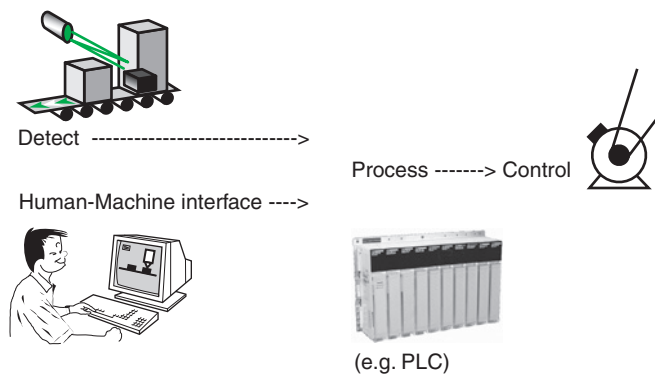


Fig. 1 : The information chain for an industrial process.

1.2 The various detection functions

Detection requirements are extremely varied. The most basic needs are as follows:

- Monitoring the presence, absence or position of an object
- Verifying the passing, travel or obstruction of objects
- Counting

These requirements are generally met using "discrete" devices, as in typical applications for detecting parts in production lines or handling activities, as well as for detecting people and vehicles.

There are other, more specific requirements, such as the detection of:

- Presence (or level) of gas or liquid
- Shape
- Position (angular, linear)

- Tags, with reading and writing of coded information

In addition to these, there are numerous requirements concerning the environment especially; depending on their location, detectors have to be resistant to:

- Moisture or immersion (e.g. watertight reinforced seal)
- Corrosion (chemical industries or even food and beverage installations)
- Extreme temperature fluctuations (e.g. tropical regions)
- All types of dirt (outside or inside machinery)
- And even vandalism...

In order to meet all these requirements, manufacturers have designed all sorts of detectors using various technologies.

1.3 The various detector technologies

Detector manufacturers utilize a number of different physical measurement principles, the most important being:

- Mechanical (pressure, force) for electromechanical limit switches
- Electromagnetism (field, force) for magnetic sensors, inductive proximity sensors
- Light (power or deflection) for photoelectric cells
- Capacitance for capacitive proximity sensors
- Acoustic (wave travel time) for ultrasonic detectors
- Fluid (pressure) for pressure switches

- Optical (image analysis) for vision

These principles offer advantages and limitations for each type of sensor: for example, some are rugged but have to be in contact with the part being detected, others can be located in aggressive environments but can only be used with metal parts.

The aim of the description of these various technologies in the following sections is to explain the installation and operating requirements for the sensors available on the market in the automation and industrial devices sector.

1.4 Auxiliary detector functions

Various functions have been developed to make detectors easier to use, self-teach mode being one.

With this teach function, the effective detection range of the device can be defined simply by

pressing a button: for example, learning the ultra-precise (± 6 mm for ultrasonic detectors) minimum and maximum ranges (suppression of foreground and background), and environment recognition for photoelectric detectors.

2 Electromechanical limit switches

Detection is achieved by means of physical contact (feeler or actuator) with an object or moving part. The information is sent to the processing system via an electrical contact (discrete).

These devices (actuator and electrical contact) are known as limit switches. They are used in all automated systems and in a wide range of applications because of the many inherent advantages in their technology.

2.1 Detection movements

A feeler or actuator may move in various ways (see Fig. 2), allowing it to detect in multiple positions and adapt easily to the objects to be detected:

- Rectilinear
- Angular
- Multi-directional

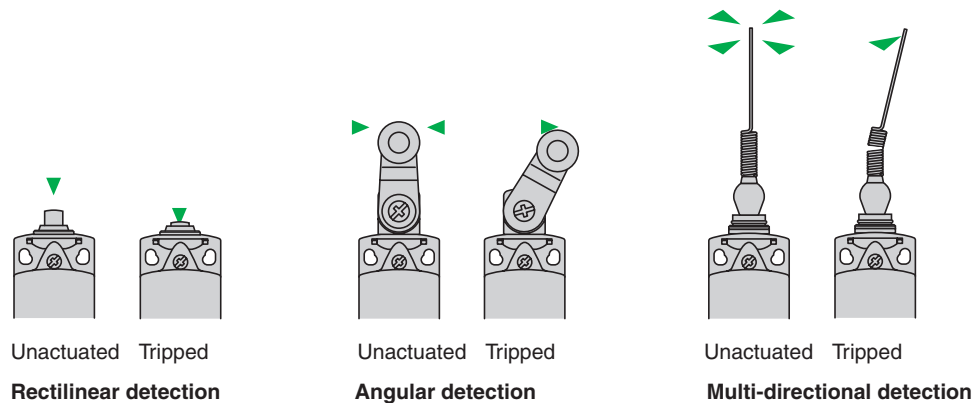


Fig. 2 : The various types of sensor movement currently in use.

2.2 Contact operating mode

The products available from manufacturers are characterized by the technology used to move the contacts.

Snap-action contact

The movement of the contacts is characterized by the phenomenon of hysteresis, in other words, by distinctly different tripping and reset points (see Fig. 3 opposite page).

The speed at which the moving contacts move is independent of the actuator speed. This feature means that satisfactory electrical performance can be obtained even at low actuator speeds.

Increasingly, limit switches with snap-action contacts have contacts with a positive opening

action: this relates to the NC contact and is defined as follows:

“A device meets this requirement when all its NC contact elements can be moved with certainty to their open position, in other words, with no flexible link between the moving contacts and the actuator to which the operating force is applied.”

This relates to the electrical contact on the limit switch (see Fig. 3) but also to the actuator, which has to transmit the movement without deformation.

The use of positive opening action devices is mandatory in safety applications.

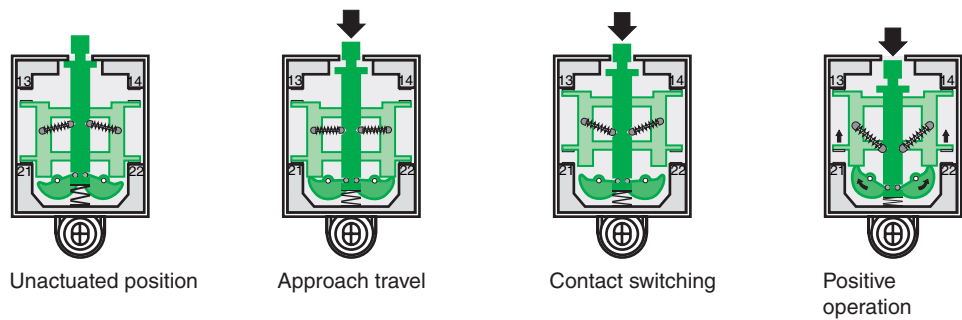


Fig. 3 : The various positions of a snap-action contact.

Slow-action contact, also known as slow break (see Fig. 4)

This operating mode is characterized by:

- Identical tripping and reset points
- Moving contact travel speed equal or proportional to the actuator speed (which must not be less than 0.1 m/s = 6 m/min). Below these values, the contacts open too slowly, which is detrimental to the correct electrical operation of the contact (risk of arc being maintained for too long).
- The opening distance also depends on the actuator travel.

The design of these contacts means that they are inherently positive opening: the plunger acts directly on the moving contacts.

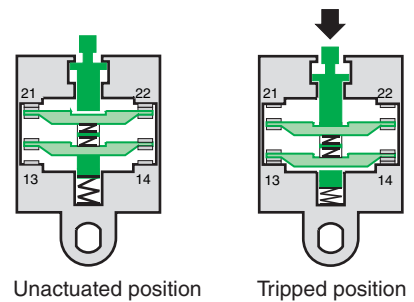


Fig. 4 : Example of a slow-action contact.

3 Inductive proximity sensors

Due to their physical operating principle, these sensors only work on metallic materials.

3.1 Principle

An inductive circuit (induction coil L) is the sensitive element. This circuit is connected to a capacitor with capacitance C to form a resonant circuit with a frequency F_o , which is generally between 100 kHz and 1 MHz.

An electronic circuit is used to maintain the system oscillations in accordance with the formula below:

$$F_o = \frac{1}{2\pi\sqrt{LC}}$$

These oscillations generate an alternating magnetic field in front of the coil.

A metal screen positioned in the field emits eddy currents, which induce an additional charge, thereby modifying the oscillation conditions (see Fig. 5).

The presence of a metal object in front of the sensor reduces the quality factor of the resonant circuit.

Case 1, without metal screen:

$$Q_1 = \frac{R_1}{L\omega}$$

$$\text{Reminder: } Q = \frac{R}{L\omega} = \frac{L\omega}{r} \Rightarrow R = Q^2 r$$

Case 2, with metal screen:

$$Q_2 = \frac{R_2}{L\omega} \quad R_2 < R_1 \Rightarrow Q_2 < Q_1$$

Detection is achieved by measuring the variation in the quality factor (from 3% to around 20% at the detection threshold).

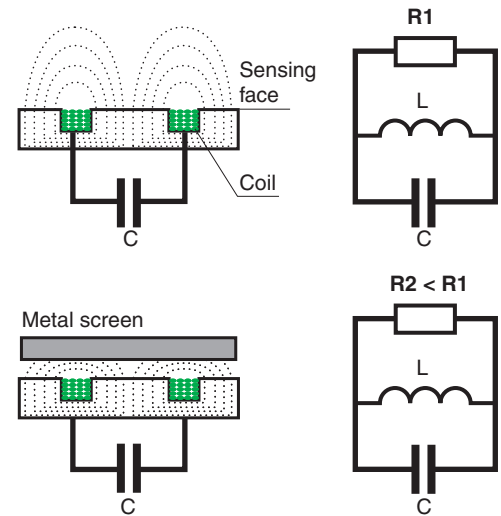


Fig. 5 : Operating principle of an inductive sensor.

The approach of the metal screen results in a reduction in the quality factor and hence a reduction in the amplitude of the oscillations. The sensing distance depends on the nature of the metal being detected (its resistivity ρ and its relative permeability μ_r).

3.2 Description of an inductive sensor (see Fig. 6a opposite page)

Transducer: This comprises a multifilament copper wire (Litz wire) coil positioned inside a half ferrite pot which directs the field lines towards the front of the sensor.

Oscillator: There are many different types of oscillator available, including oscillators with a fixed negative resistance $-R$, which is equal in absolute value to the parallel resistance R_p of the oscillating circuit at the nominal range (see preceding section).

=> If the object to be detected is beyond the nominal range, $|R_p| > |-R|$ so oscillation is maintained.

=> Conversely, if the object to be detected is inside the nominal range, $|R_p| < |-R|$ so

oscillation is not maintained and the oscillator is blocked.

Shaping stage: This comprises a peak detector followed by a comparator with two thresholds (trigger) to prevent untimely switching when the object to be detected is close to the nominal range. It creates what is known as the sensor hysteresis (see Fig. 6b opposite page).

Supply and output stages: The one allows the sensor to be powered across a broad supply voltage range (from 10 V DC to 264 V AC). The other, the output stage, controls loads from 0.2 A DC to 0.5 A AC, with or without short-circuit protection.

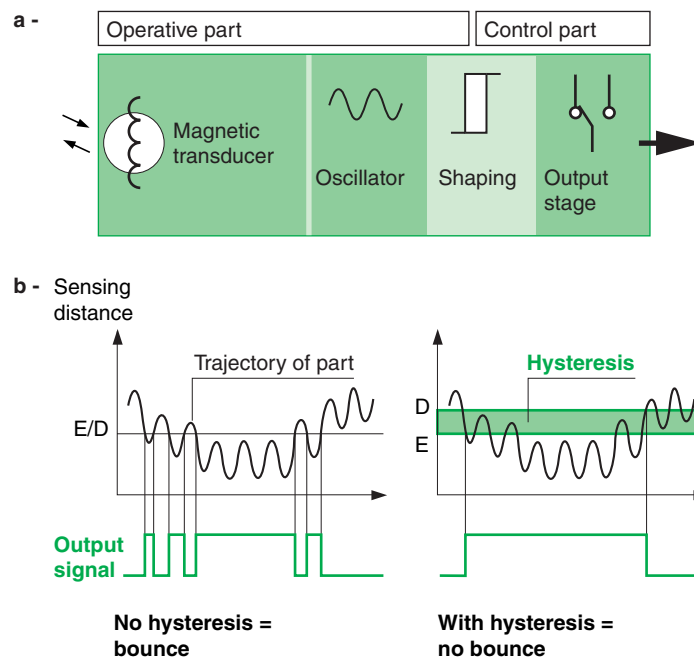


Fig. 6 : Diagram of an inductive sensor, [a] principle, [b] sensor hysteresis.

3.3 Influence quantities in inductive sensing

Certain characteristics particularly affect inductive sensing devices, notably:

- Sensing distance

This depends on the size of the sensing area. Sn: Nominal range (on mild steel) varies from 0.8 mm (sensor diameter 4) to 60 mm (sensor 80 x 80).

- Hysteresis: Differential travel (from 2 to 10% of Sn), which prevents bouncing on switching

- Frequency of passage of objects in front of the sensor, known as the switching frequency (maximum current 5 kHz).

3.4 Specific functions

- Sensors protected against magnetic fields generated by welding machines

- Analog output sensors

- Sensors with a correction factor of 1, where the sensing distance is independent of whether the metal being detected is ferrous or non-ferrous (see Fig. 7)

- Selective sensors for ferrous and non-ferrous materials

- Rotation control sensors: These underspeed sensors are sensitive to the frequency of passage of metal objects.

- Sensors for explosive atmospheres (NAMUR standards)

- Application: If the object to be detected is not steel, the sensing distance for the sensor in question is proportional to the correction factor for the material from which the object is made.

$$D_{Mat} \times = D_{Steel} \times K_{Mat} \times$$

- Typical values for the correction factor ($K_{Mat} \times$) are:

- Steel = 1

- Stainless steel = 0.7

- Brass = 0.4

- Aluminum = 0.3

- Copper = 0.2

Example: $D_{Stainless} = D_{Steel} \times 0.7$

NB: This correction is unnecessary with "factor 1" sensors.

Fig. 7 : Correction factor, application and typical values.

4 Capacitive proximity sensors

This technology can be used to detect all types of conductive and insulating materials, such as glass, oil, wood and plastics.

4.1 Principle

The sensing face of the sensor constitutes the armature of a capacitor.

A sine-wave voltage is applied to this face, creating an alternating electrical field in front of the sensor.

Since this sine-wave voltage is referenced in relation to a reference potential (ground or machine ground, for example), the second armature consists of an electrode connected to this reference potential (machine frame, for example).

These two electrodes facing each other form a capacitor of capacitance:

$$C = \frac{\epsilon_0 \cdot \epsilon_r \cdot A}{d}$$

where $\epsilon_0 = 8.854\ 187\ \text{pF/m}$ is the absolute permittivity of the vacuum and ϵ_r the relative permittivity of the material between the two electrodes.

Case 1: No object between the 2 electrodes (see Fig. 8)

$$\epsilon_r \approx 1 \text{ (air)} \Rightarrow C \approx \epsilon_0 \frac{A}{d}$$

Case 2: Insulating object between the 2 electrodes (see Fig. 9)

$$\Rightarrow (\epsilon_r \approx 4)$$

In this case the ground electrode can be the metal belt of a conveyor, for example.

$$C = \frac{\epsilon_0 \cdot \epsilon_r \cdot A}{d}$$

When the mean ϵ_r becomes greater than 1 in the presence of an object, C increases.

Measuring the increase in the value of C allows the presence of the insulating object to be detected.

Case 3: Conductive object between the 2 electrodes (see Fig. 10)

$$C = \frac{\epsilon_0 \cdot \epsilon_r \cdot A}{d-e}$$

$$\text{where } \epsilon_r \approx 1 \text{ (air)} \Rightarrow C \approx \epsilon_0 \frac{A}{d-e}$$

The presence of a metal object thus leads to a rise in the value of C.

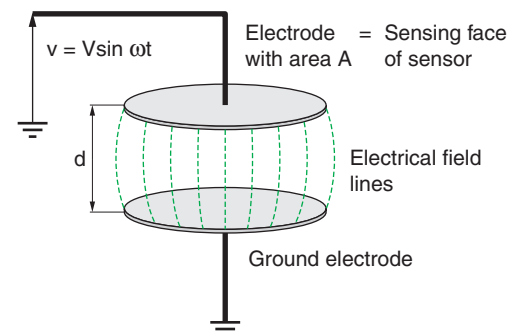


Fig. 8 : Capacitive sensor with no object to detect.

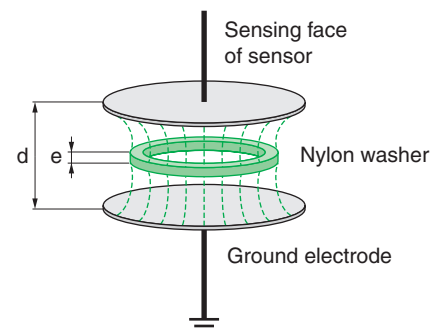


Fig. 9 : Insulating object on a capacitive sensor.

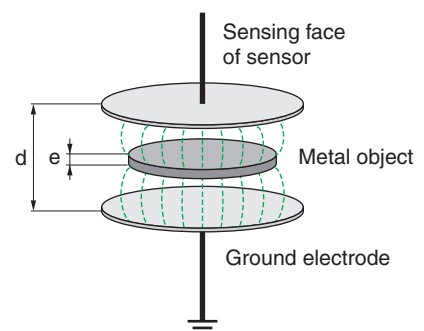


Fig. 10 : Conductive object on a capacitive sensor.

4.2 The various types of capacitive sensor

Capacitive sensors without a ground electrode

These sensors use the principle described above.

A path to ground (reference potential) is needed in order to detect an object.

They are used for detecting conductive materials (metal, water) at considerable distances.

Typical application: Detection of conductive materials through an insulating material (see Fig. 11).

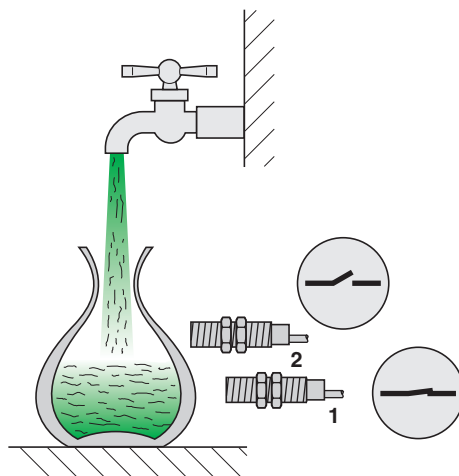


Fig. 11 : Detection of the presence of water in a glass or plastic container.

Capacitive sensors with a ground electrode

It is not always possible to find a path to ground, as would be the case if we wanted to detect the insulating container in the previous example.

The solution, therefore, is to incorporate the ground electrode on the sensing face.

This creates an electrical field, which is independent from a path to ground (see Fig. 12).

Application: Detection of all materials.

Possibility of detecting insulating or conductive materials behind an insulating partition, e.g. cereals in a cardboard box.

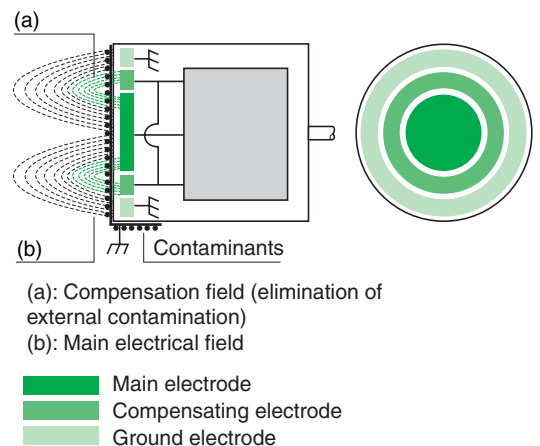


Fig. 12 : Principle of a capacitive sensor with ground electrode.

4.3 Influence quantities for a capacitive sensor

The sensitivity of capacitive sensors according to the basic equation cited above (section 4.1) depends on both the distance between the object and the sensor and the material from which the object is made.

■ Sensing distance

This is linked to the dielectric constant or relative permittivity ϵ_r of the material from which the target object is made.

To enable them to detect a wide variety of materials, capacitive sensors are generally equipped with a potentiometer, which allows their sensitivity to be adjusted.

■ Material

The table in Figure 13 gives the dielectric constants of a number of materials.

Material	ϵ_r	Material	ϵ_r
Acetone	19.5	Petroleum	2.0-2.2
Air	1.000264	Silicon varnish	2.8-3.3
Ammonia	15-25	Polypropylene	2.0-2.2
Ethanol	24	Porcelain	5-7
Flour	2.5-3	Powdered milk	3.5-4
Glass	3.7-10	Salt	6
Glycerin	47	Sugar	3.0
Mica	5.7-6.7	Water	80
Paper	1.6-2.6	Wood (dry)	2-6
Nylon	4-5	Wood (green)	10-30

Fig. 13 : Dielectric constants of various materials.

5 Photoelectric sensors

The operating principle of these sensors allows them to detect all types of object, including opaque, reflective and even almost transparent

objects. They are also used for detecting people (automatic doors, security barriers).

5.1 Principle (see fig. 14)

A light-emitting diode (LED) emits pulses of light, generally in the near infrared range (850 to 950 nm).

This light is received or not received by a photodiode or phototransistor, depending on whether an object to be detected is present.

The photoelectric current generated is amplified and compared with a reference threshold to provide a discrete signal.

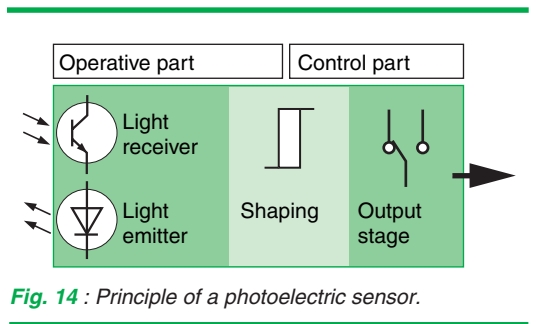


Fig. 14 : Principle of a photoelectric sensor.

5.2 The various detection systems

The diagrams representing the reflex photoelectric detection systems presented in this section are intended purely as an aid to understanding the devices used. They are not an accurate optical representation, as the distance between the object and the detector is far greater than the gap between the emitter and the receiver; the emitted and received rays can thus be considered to be parallel.

Thru-beam (see Fig. 15)

The emitter and receiver are contained in separate housings.

The emitter: a LED positioned at the focal point of a focusing lens, creates a parallel light beam.

The receiver: a photodiode (or phototransistor) positioned at the focal point of a focusing lens, supplies a current, which is proportional to the energy received.

The system supplies a discrete signal according to the presence or absence of the object in the beam.

□ Strength: The sensing distance (range) can be long (up to 50 m or more); it depends on the size of the lenses and therefore of the sensor.

□ Weaknesses: The need for 2 housings, hence 2 separate power supplies, and for sensing

distances of more than 10 m alignment can also be difficult.

Reflex systems

There are actually two types of “reflex” system: standard reflex and polarized reflex.

■ Reflex (see Fig. 16 opposite page)

The light beam is generally in the near infrared range (850 to 950 nm).

□ Strengths: The emitter and receiver are in the same housing (only one supply cable). The sensing distance (range) is still long, although shorter than that for thru-beam systems (up to 20 m).

□ Weakness: A reflective object (window, car body, etc.) may be interpreted as a reflector and not detected.

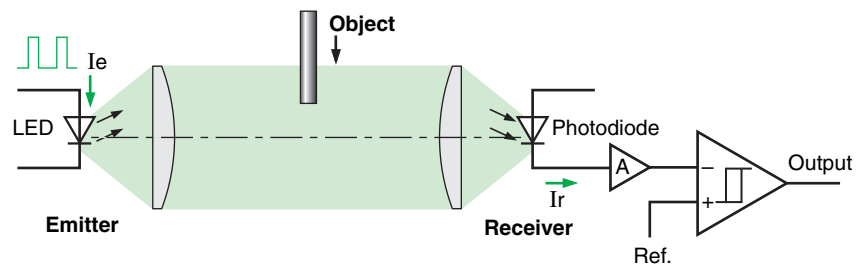


Fig. 15 : Thru-beam detection.

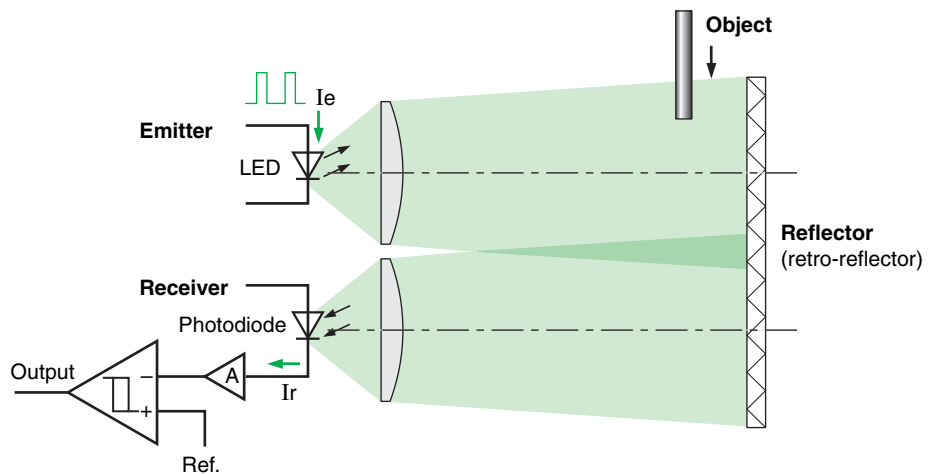


Fig. 16 : Principle of reflect photoelectric detection.

■ Polarized reflex (see Fig. 17)

The light beam used is generally in the red range (660 nm).

The emitted radiation is polarized vertically by a linear polarizing filter.

The reflector changes the polarization state of the light, so part of the radiation returned has a horizontal component.

The receiving linear polarizing filter allows this component to pass through and the light reaches the receiver.

■ Unlike the reflector, a reflective object (mirror, sheet metal, window) does not change the polarization state. The light reflected by the object is therefore unable to reach the receiving polarizer (see Fig. 18 next page).

□ Strength: This type of sensor overcomes the weakness of standard reflex detection.

□ Weaknesses: However, it is more expensive and the sensing distances are shorter:

IR reflex → 15 m

Polarized reflex → 8 m

Diffuse system (on object)

■ Standard diffuse (see Fig. 19 next page)

This system utilizes the direct reflection (diffuse) from the object to be detected.

□ Strength: No reflector is needed.

□ Weaknesses: The sensing distance for this system is very short (up to 2 m). It also varies according to the color of the object to “see” and the background behind it (at a given setting, the sensing distance is longer for a white object than for a gray or black object), and a background, which is lighter than the object to be detected can make detection impossible.

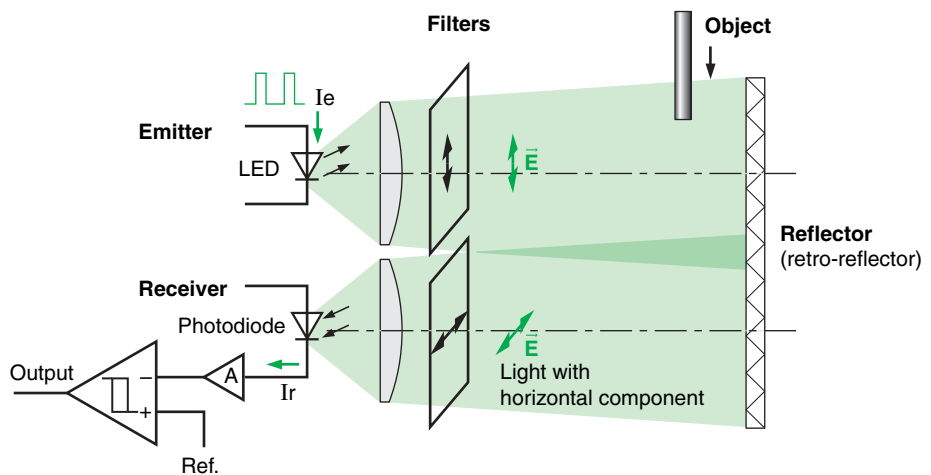


Fig. 17 : Principle of polarized reflex photoelectric detection.

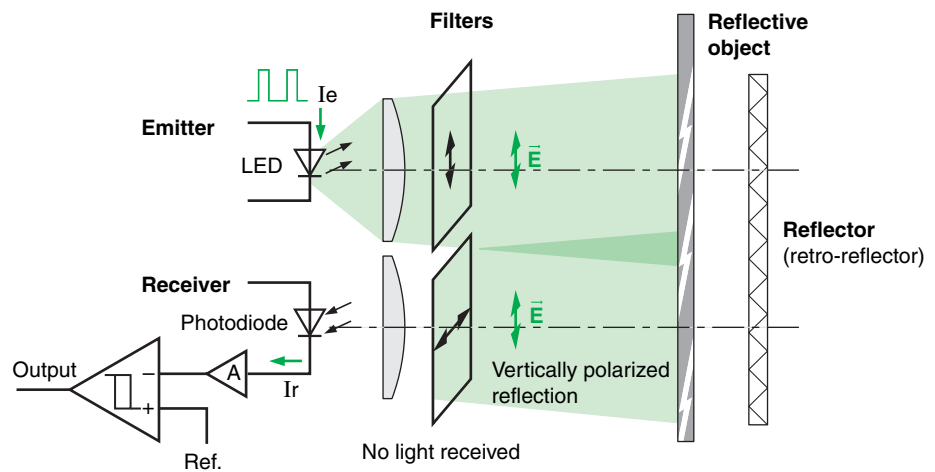


Fig. 18 : Polarized reflex system: principle of the non-detection of reflective materials.

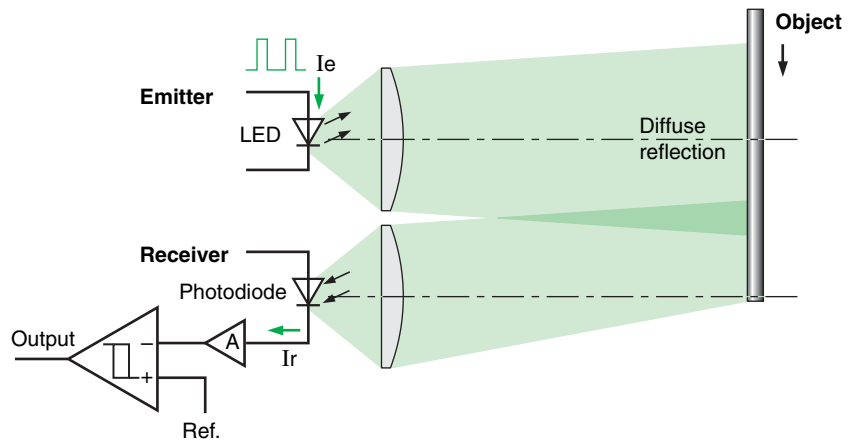


Fig. 19 : Principle of standard diffuse photoelectric detection.

■ Diffuse with background suppression (see Fig. 20)

This detection system uses triangulation. The sensing distance (up to 2 m) does not depend on

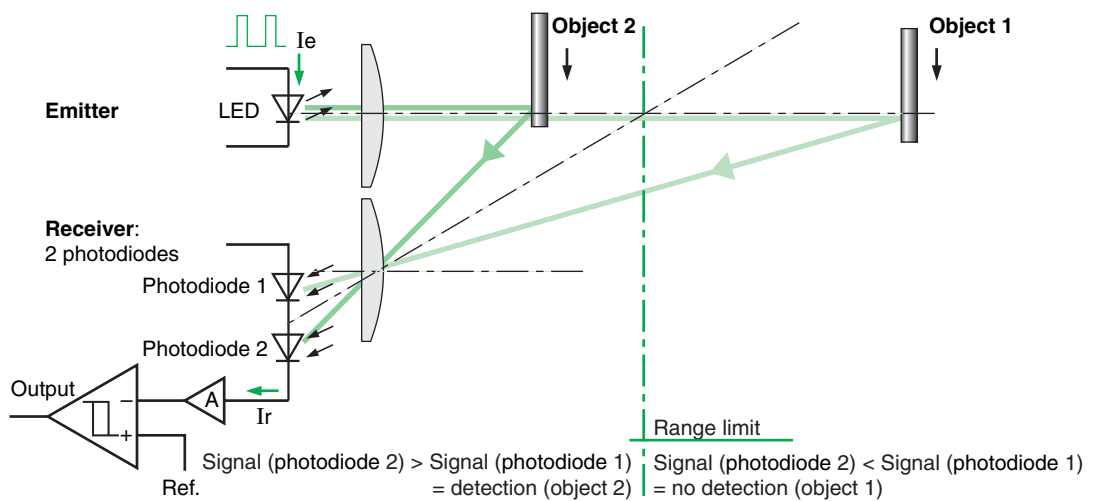


Fig. 20 : Principle of diffuse photoelectric detection with background suppression.

the reflectivity of the object, only on its position: a light object is detected at the same distance as a dark one.

In addition, any background beyond the sensing zone is ignored.

Optical fibers

■ Principle

A reminder of the principle can be found in **Figure 21**. There are different types of optical fiber: multimode and single-mode (see **Fig. 22**).

The propagation of light waves in an optical fiber is based on total internal reflection.

Total internal reflection occurs when a light ray passes from one medium to another, which has a lower refractive index. Furthermore, light is completely reflected with no loss of light when the angle of incidence of the light ray is greater than the critical angle θ_c .

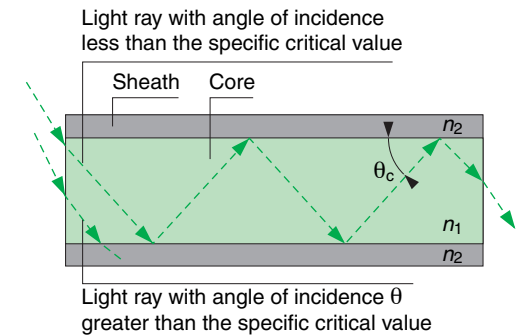
Total internal reflection is governed by two factors: the refractive indexes of the two media and the critical angle.

These factors are linked by the following equation:

$$\sin \theta_c = \frac{n_2}{n_1}$$

If we know the refractive indexes of the two interface materials, the critical angle is simple to calculate.

Physics defines the refractive index of a substance as the relation between the speed of light in a vacuum (c) and its speed in the material (v).



$$n = \frac{c}{v}$$

The index of air is considered to be equal to that of a vacuum, 1, since the speed of light in air is almost equal to that in a vacuum.

Fig. 21: Principle of the propagation of light waves in fiber optics.

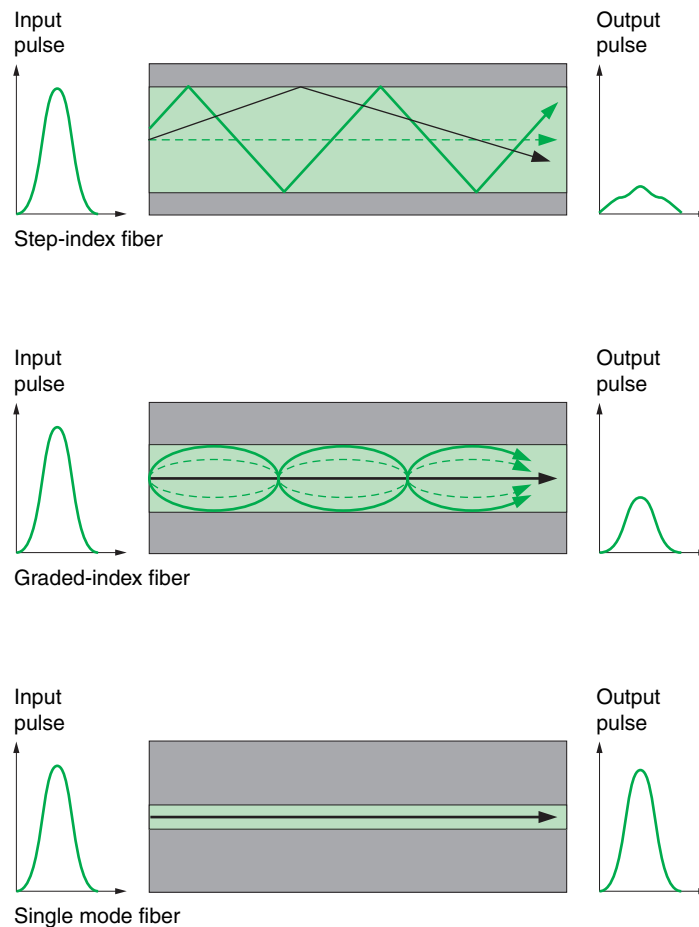


Fig. 22: The different types of optical fiber.

■ Multimode fibers

These are fibers in which the central core, which conducts the light, has a large diameter in comparison to the wavelength used ($\Phi \approx 9$ to $125 \mu\text{m}$, $L_o = 0.5$ to 1 mm). Two types of propagation are used in these fibers: step-index or graded-index.

■ Single-mode

By contrast, these fibers have a very small diameter in comparison to the wavelength used ($\Phi \leq 10 \mu\text{m}$, $L_o =$ generally 1.5 mm). They use step-index propagation. These fibers are mainly used in telecommunications.

This brief reminder illustrates the care that has to be taken when using these fibers, in terms of pulling them, for example (reduced tensile strength and moderate radii of curvature, according to manufacturers' specifications).

Multimode optical fibers are the most widely used in industry, as they offer the advantages of

electromagnetic ruggedness (EMC – electromagnetic compatibility) and ease of use.

■ Sensor technology

The optical fibers are positioned in front of the emitting LED and in front of the receiving photodiode or phototransistor (see Fig. 23).

This principle allows:

- Positioning of electronic components away from the monitoring point
- Use in confined areas or at high temperature
- Detection of very small objects (mm range)
- Depending on the configuration of the fiber ends, operation in thru-beam or proximity mode

Note that the connections between the emitting LED or the receiving phototransistor and the optical fiber must be made with extreme care to minimize light signal losses.

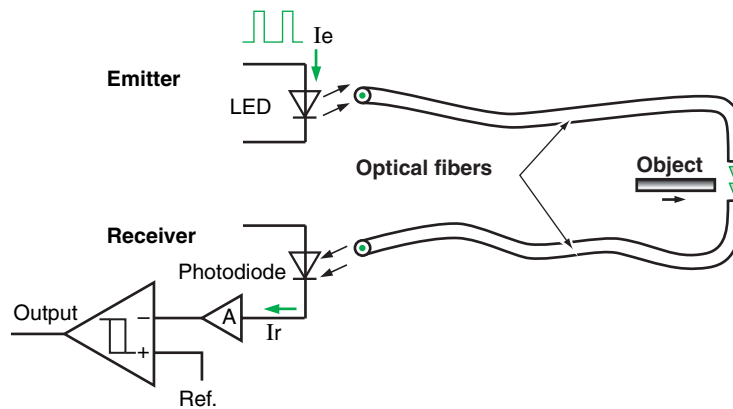


Fig. 23 : Principle of a fiber optic sensor.

5.3 Influence quantities in detection using photoelectric systems

A number of factors can influence the performance of these detection systems.

Some have been mentioned already:

- Distance (sensor-object)
- Type of object to be detected (diffusing, reflective or transparent material, color, and size)
- Environment (ambient light, background, etc.)

6 Ultrasonic sensors

6.1 Principle

Ultrasonic waves are produced electrically using an electroacoustic transducer (piezoelectric effect), which converts electrical energy supplied to it in the form of mechanical vibrations thanks to piezoelectricity or magnetostriction phenomena (see Fig. 24).

The principle involves measuring the propagation time for the acoustic wave between the sensor and the target.

The propagation speed is 340 m/s in air at 20°C: for example, for 1 m the measuring time is about 3 ms. This time is measured by the counter on a microcontroller.

The advantage of ultrasonic sensors is that they can operate over long distances (up to 10 m) and, above all, that they can detect any object, which reflects sound, regardless of its shape or color.

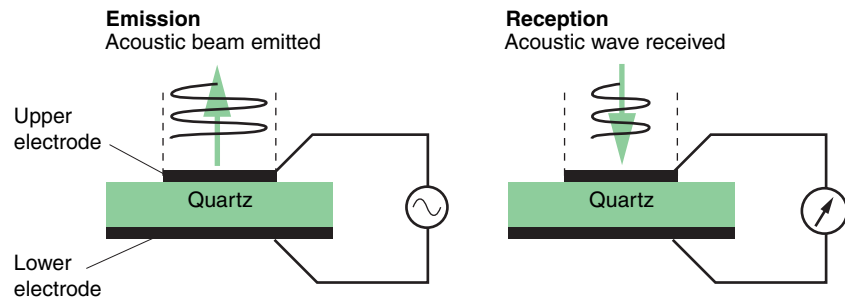


Fig. 24 : Principle of an electroacoustic transducer.

6.2 Application (see Fig. 25)

Excited by the high-voltage generator, the transducer (emitter-receiver) generates a pulsed ultrasonic wave (100 to 500 kHz, depending on the product), which moves through the ambient air at the speed of sound.

As soon as the wave meets an object, a reflected wave (echo) returns to the transducer. A microprocessor analyzes the signal received and measures the time interval between the emitted signal and the echo.

By comparing it with predefined or learned times, it determines and monitors the status of the outputs. If we know the sound propagation speed, we can calculate a distance using the following formula:

$$D = \frac{T \cdot V_s}{2} \text{ where}$$

D is the distance from the sensor to the object
T is the time elapsed between emission and reception of the wave

V_s is the speed of sound (300 m/s)

The output stage monitors a static switch (PNP or NPN transistor) corresponding to a NO or NC contact, or provides an analog signal (current or voltage), which is directly or inversely proportional to the measured distance of the object.

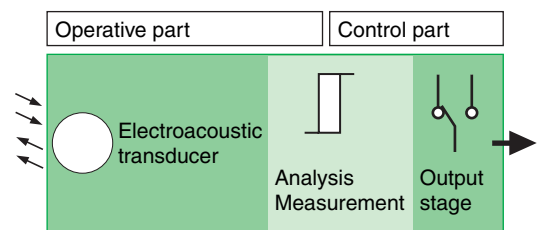


Fig. 25 : Principle of an ultrasonic sensor.

6.3 Special features of ultrasonic sensors

Definitions (see Fig. 26)

Blind zone: Zone between the sensing face of the sensor and the minimum range, within which no object can be reliably detected. It is impossible to detect objects correctly in this zone. Therefore objects should never be allowed to pass through the blind zone when the sensor is operating. This could cause an unstable output state.

Sensing zone: The area within which the sensor is operational. Depending on the sensor model, this zone can be adjustable or fixed using a simple pushbutton.

Influence quantities: Ultrasonic sensors are particularly suitable for detecting hard objects with a plane surface perpendicular to the detection axis.

However, the function of an ultrasonic detector can be disrupted by various factors:

- Sudden or strong air currents can accelerate or divert the acoustic wave emitted by the product (ejection of part by air jet)

- Steep temperature gradients in the sensing zone

High temperatures given off by an object create differing temperature zones, which alter the wave propagation time and prevent reliable detection.

- Sound-absorbing materials

Materials such as cotton, tissue, rubber absorb sound; "reflex" detection mode is recommended for these products.

- The angle between the face of the target object and the reference axis of the sensor
If this angle does not equal 90° , the wave is not reflected in the axis of the detector and the operating range is reduced. The greater the

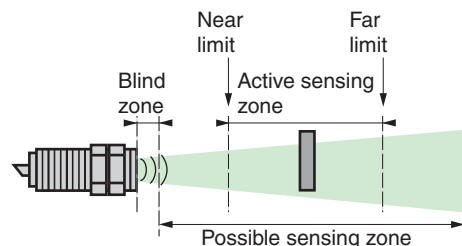


Fig. 26 : Operating limits for an ultrasonic sensor.

distance between the object and the sensor, the more apparent this effect becomes. Above $\pm 10^\circ$, detection is impossible.

- The shape of the target object

As a consequence of the previous factor, a very angular object is more difficult to detect.

Operating mode (see Fig. 27)

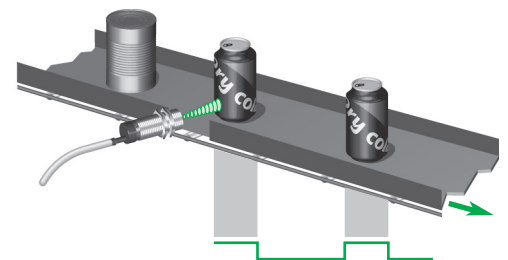
Diffuse mode: A single sensor emits the sound wave and then receives it after reflection by an object.

In this case, the object reflects the wave.

Reflex mode: A single sensor emits the sound wave and then receives it after reflection by a reflector, so the sensor is permanently active. The reflector in this case is a flat, solid part. This can be part of the machine. The object is detected in this case when the wave is broken. This mode is especially suitable for detecting absorbent materials or angular objects.

Thru-beam mode: The thru-beam system comprises two separate products, which are positioned opposite each other: an ultrasonic emitter and a receiver.

a -



b -

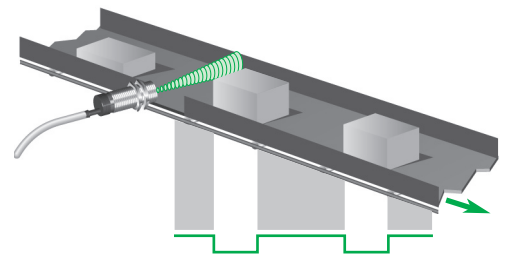


Fig. 27 : Use of ultrasonic sensors a/ In proximity or diffuse mode, b/ In reflex mode.

6.4 Advantages of ultrasonic detection

- No physical contact with the object, so no wear; also allows detection of fragile or freshly painted objects
- Any material, regardless of its color, can be detected at the same range, with no adjustment or correction factor
- Static devices: No moving parts inside the sensor, so its service life is unaffected by the number of operating cycles
- Good resistance to industrial environments: vibration- and impact-resistant devices, devices resistant to damp and dusty environments.

7 RFID detection (Radio Frequency Identification)

This section covers devices designed to store and use data held in electronic tags, using a radio frequency signal.

7.1 Background

- Radio Frequency IDentification (RFID) is a relatively new automatic identification technology suitable for applications requiring the tracking of objects or people (traceability, access control, sorting, storage).
- The principle is based on giving each object a remotely accessible read/write storage capacity.

- The data is stored in a memory, which is accessible via a simple radio frequency link, requiring no contact or field of vision, at a distance ranging from a few cm to several meters. This memory takes the form of an electronic tag, also known as a transponder (TRANSmitter + resPONDER), inside which there is an electronic circuit and an antenna.

7.2 Operating principles

An RFID system comprises the following elements (see Fig. 28 and 29):

- An electronic tag
- A read/write station (or RFID reader)

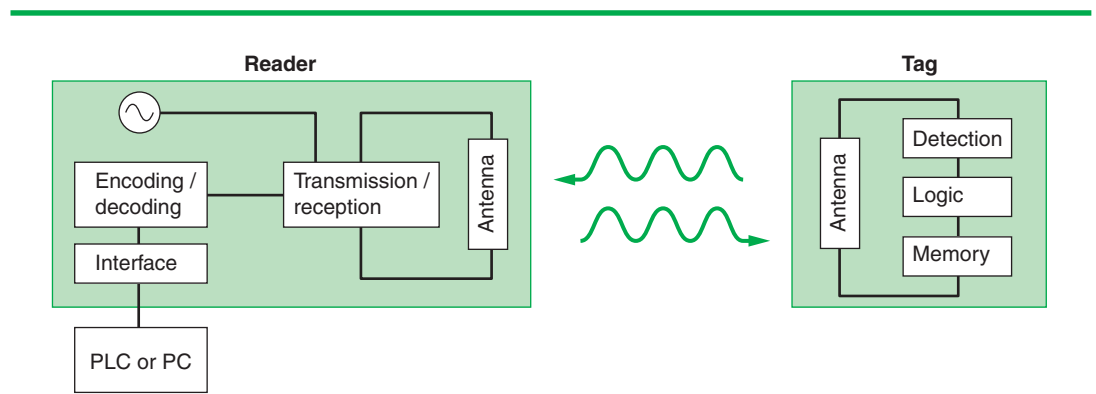


Fig. 28 : Configuration of an RFID system.

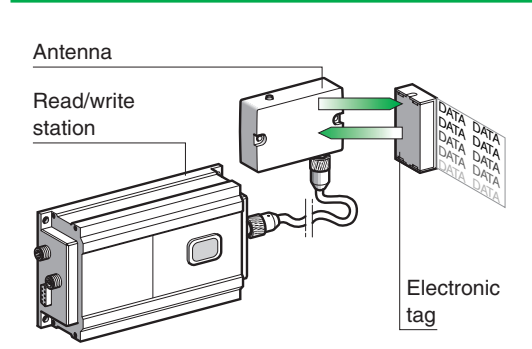


Fig. 29 : Elements of an RFID system (Inductel system from Telemecanique).

Reader

The reader modulates the amplitude of the field radiated by its antenna to transmit read or write commands to the tag processing logic. Simultaneously, the electromagnetic field generated by its antenna powers the electronic circuit in the tag.

Tag

The tag feeds back its data to the antenna in the reader, modulating its own consumption. This modulation is detected by the reader's receive circuit, which converts it to digital signals (see Fig. 30 opposite page).

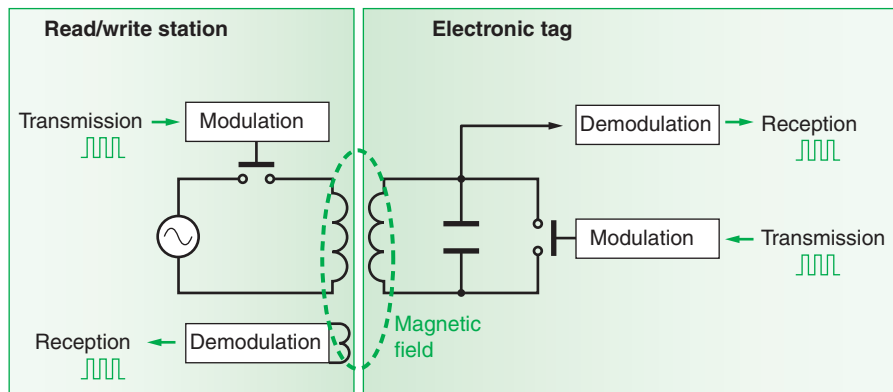


Fig. 30 : Operation of an RFID system.

7.3 Description of the components

Electronic tags

The electronic tags comprise three main elements contained in a casing.

- An antenna (see Fig. 31)

This must be adjusted to the frequency of the carrier. Various types can be used:

- Copper wire coil, with or without ferrite core (channeling of field lines), or etched on a flexible or rigid printed circuit, or printed (conductive ink) for frequencies below 20 MHz
- Dipole etched on a printed circuit, or printed (conductive ink) for very high frequencies (> 800 MHz)

- A logic circuit for processing (see Fig. 31)

This acts as an interface between the commands received by the antenna and the memory. Its level of complexity depends on the application, from simple shaping to the use of a microcontroller (e.g. payment cards secured with encryption algorithms).

- A memory

Various types of memory are used for storing data in electronic tags (see Fig. 32).

- The memory capacity can range from a few bytes to tens of kilobytes.

Note: "Active" tags contain a battery, which powers their electronic components. This

configuration increases the communication distance between the tag and the antenna, but requires regular replacement of the battery.

- Casing

Casings appropriate to each type of application have been created to hold and protect these three active elements of a tag, such as:

- Credit card format badge, for access control (see Fig. 33a next page)

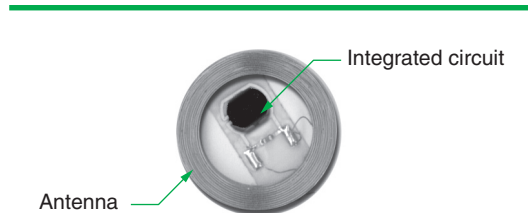


Fig. 31 : Photograph of an RFID tag.

Type	Advantages	Disadvantages
ROM	<ul style="list-style-type: none"> ■ Good resistance to high temperatures ■ Low cost 	<ul style="list-style-type: none"> ■ Read only
EEPROM	<ul style="list-style-type: none"> ■ No battery or backup battery 	<ul style="list-style-type: none"> ■ Relatively long read/write access time ■ Number of write operations limited to 10^5 cycles per byte
RAM	<ul style="list-style-type: none"> ■ Rapid access to data ■ High capacity ■ Unlimited number of read or write operations 	<ul style="list-style-type: none"> ■ Backup battery needed in tag
FeRAM (ferro-electric)	<ul style="list-style-type: none"> ■ Rapid access to data ■ No battery or backup battery ■ High capacity 	<ul style="list-style-type: none"> ■ Number of read/write operations limited to 10^{12}

Fig. 32 : Various types of memory used to store data in electronic tags.

- Adhesive support, for identification of books in libraries (see Fig. 33b)
- Glass tube, for pet identification (injected under the skin using a syringe) (see Fig. 33c)
- Plastic “buttons”, for identification of clothes and laundry (see Fig. 33d and 33e)
- Label for mail tracking (see Fig. 33g)

There are many other formats too: key ring, plastic “nail” for identification of wooden pallets, shock-proof and chemical-resistant casings (see Fig. 33h), for industrial applications (surface treatment, furnaces, etc.).

Stations

A station (see Fig. 34a) acts as an interface between the control system (programmable PLC, computer, etc.) and the electronic tag, via a suitable communication port (RS232, RS485, Ethernet, etc.).

It can also include a number of complementary functions appropriate to the particular application:

- Discrete inputs/outputs
- Local processing for stand-alone operation
- Control of multiple antennas
- Detection with integral antenna for a compact system (see Fig. 34b).

Antennas

Antennas are characterized by their dimensions (which determine the shape of the zone in which they will be able to exchange information with the tags) and the frequency of the radiated field. The use of ferrite cores allows the electromagnetic field lines to be concentrated, increasing the reading distance (see Fig. 35) and reducing the influence of metal bodies which might be close by the antenna.

The frequencies used by the antennas cover several distinct bands, each of which offers advantages and disadvantages (see Fig. 36 opposite page).

The power ratings and frequencies used vary according to the application and country. Three major zones have been identified: North America, Europe, and Rest of World. Each zone and each frequency has an authorized emission spectrum range (CISPR standard 300330), within which each RFID station/antenna must operate.

Codes and protocols

International standards define the exchange protocols between stations and tags (ISO 15693 – ISO 14443 A/B).

More specialized standards are also in the process of being defined, such as those intended for mass product distribution (EPC - Electronic Product Code) or for the identification of animals (ISO 11784).

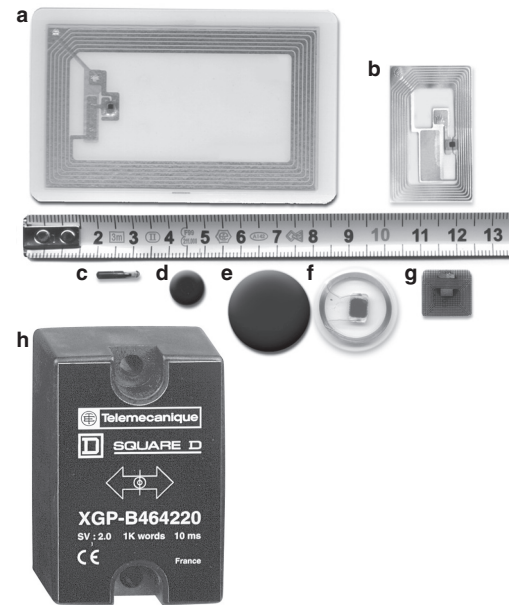


Fig. 33 : Various application-related RFID tag formats.

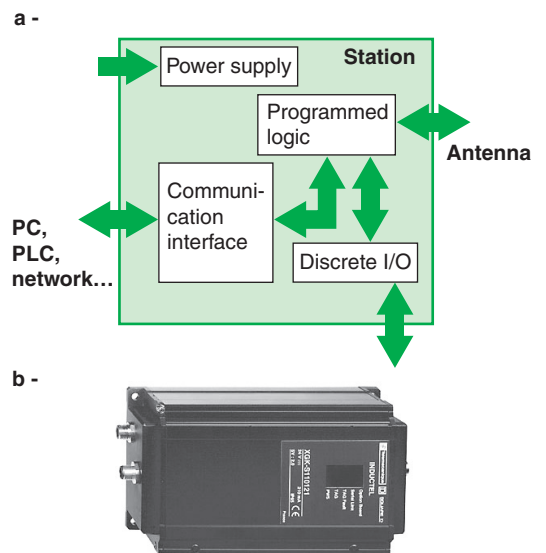


Fig. 34 : Diagram and photograph of an RFID reader (Telemecanique Inductel station).

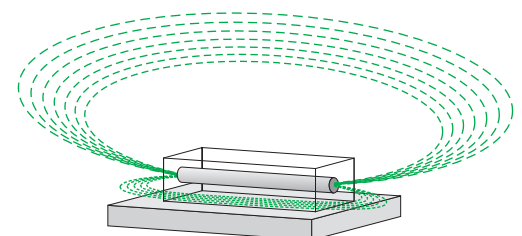


Fig. 35 : Influence of a ferrite antenna on electromagnetic field lines.

Frequency	Advantages	Disadvantages	Typical application
125-134 khz (LF)	<ul style="list-style-type: none"> ■ Immunity to environment (metal, water) 	<ul style="list-style-type: none"> ■ Low memory capacity ■ Long access time 	<ul style="list-style-type: none"> ■ Pet identification
13.56 Mhz (HF)	<ul style="list-style-type: none"> ■ Standardized antenna/tag communication protocols (ISO 15693 – ISO 14443 A/B) 	<ul style="list-style-type: none"> ■ Sensitivity to metallic environments 	<ul style="list-style-type: none"> ■ Tracking of books in libraries ■ Access control ■ Payment systems
850 - 950 Mhz (UHF)	<ul style="list-style-type: none"> ■ Very low tag cost ■ Long communication range (several meters) 	<ul style="list-style-type: none"> ■ Frequency ranges not standardized between countries ■ Interference in communication zones due to obstacles (metal, water) 	<ul style="list-style-type: none"> ■ Product management in distribution
2.45 Ghz (microwave)	<ul style="list-style-type: none"> ■ Very high transfer speed between antenna and tag ■ Long communication range (several meters) 	<ul style="list-style-type: none"> ■ “Holes” in communication zone difficult to control ■ Cost of reading systems 	<ul style="list-style-type: none"> ■ Vehicle tracking (freeway tolls)

Fig. 36 : Description of the frequency bands used in RFID.

7.4 Advantages of RFID

In comparison to barcode systems (labels or marks and readers), RFID identification offers the following advantages:

- Possible modification of data contained in the tag
- Read/write access through most non-metallic materials
- Not sensitive to dust, dirt, etc.
- Ability to record several thousand characters in one tag
- Data confidentiality (locking of access to data contained in the tag)

These advantages all contribute to the growing use of this technology in the service sector (e.g. access control to ski runs) and in distribution.

In addition, the steady fall in cost of RFID tags should lead to RFID tags replacing traditional barcodes on containers (boxes, parcels, baggage) in areas such as logistics and transport, and also on products during the manufacturing process in industry.

For physical and technical reasons, however, it should be noted that the appealing idea of the automatic identification of the contents of shopping carts at supermarket checkouts, without the need to unload the goods, is not yet achievable.

8 Vision

8.1 Principle

Vision systems are the “eye” of a machine, giving sight to an automation system.

On a photograph taken by a camera, the physical characteristics of an object are digitized (see **Fig. 37**), providing information about its:

- Dimensions
- Position
- Appearance (surface finish, color, gloss, presence of defects)
- Markings (logos, characters, etc.)

The user can also automate complex functions:

- Measurement
- Guidance, and
- Identification

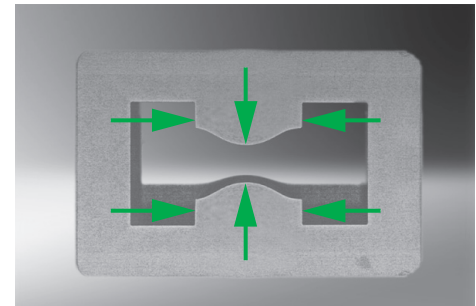


Fig. 37 : Inspection of a mechanical component. The arrows show the areas checked by the system.

8.2 Key points in vision

Industrial vision comprises an optical system (lighting, camera, and lens), together with a processing unit and actuator control system.

■ Lighting

It is vital to have appropriate lighting, specially designed to create an adequate, stable contrast, to highlight the elements to be inspected.

■ Camera and lens

The choice of lens and camera determines the quality of the image that is recorded (contrast, sharpness), at a defined distance between camera and object and with a well-defined object to be examined (dimensions, surface finish, details to be recorded).

■ Processing unit

The image from the camera is sent to a processing unit, which contains the manipulation and image analysis algorithms needed to carry out the checks.

The results are then sent to the automation system or trigger a direct actuator response.

Lighting systems

■ Lighting technology:

- High-frequency fluorescent tube lighting
This white light has a long service life (5000 hours) and the area illuminated (“field”) is large, determined of course by the lighting power used.
- Halogen lighting
This form of white light has a short service life (500 hours) but with a very high lighting power it can cover a large field.

□ LED lighting (light-emitting diode)

This is currently the preferred lighting system: it provides uniform lighting with a very long service life (30,000 hours). It is available in color, but the field covered is limited to about 50 cm.

■ These lighting technologies can be applied in various ways. Five main systems are used (see **Fig. 38** opposite page) to highlight the features to be checked:

- Ring light
- Back light
- Direct front light
- Dark field
- Coaxial

Cameras and lenses

■ Camera technologies

- CCD (charged coupled device) camera
These cameras are preferred nowadays for their good definition.
For continuous processes, linear cameras (linear CCD) are used. In all other cases, matrix cameras (matrix CCD) are used.
Industrial cameras utilize various sensor formats (see **Fig. 39** opposite page), defined in inches: 1/3, 1/2 and 2/3 (1/3 and 1/2: camcorder, 2/3 or more: industrial high resolution, television, etc.). There are specific lenses for each sensor format to allow full use of the pixels.
- CMOS camera: Gradually being superseded by CCD. Inexpensive ⇒ used for basic applications
- Vidicon camera (tube): Now obsolete.

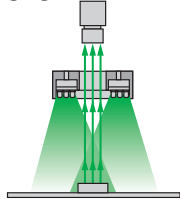
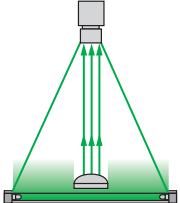
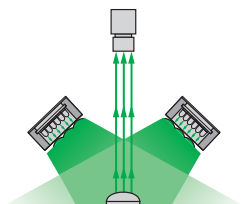
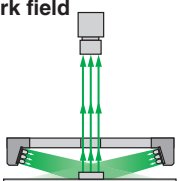
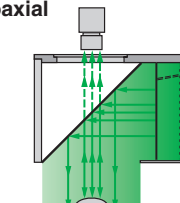
Systemes	Characteristics	Typical applications
Ring light 	<ul style="list-style-type: none"> ■ Set of LEDs arranged in a ring ■ Very powerful lighting system: lights the object in its axis, from above 	<ul style="list-style-type: none"> ■ Precision inspection, of markings for example
Back light 	<ul style="list-style-type: none"> ■ Light positioned behind the object and facing the camera ■ Highlights the silhouette of the object (shadowgraph) 	<ul style="list-style-type: none"> ■ Measuring the dimensions of an object: or for analyzing opaque items
Direct front light 	<ul style="list-style-type: none"> ■ Used to highlight a small area of the object being examined and to create a heavy shadow 	<ul style="list-style-type: none"> ■ Finding specific defects, inspection of internal screw threads, etc.
Dark field 	<ul style="list-style-type: none"> ■ Used for: <ul style="list-style-type: none"> □ Edge detection □ Checking markings □ Detecting faults on glass or metal surfaces 	<ul style="list-style-type: none"> ■ Checking printed characters, surface finish, scratch detection, etc.
Coaxial 	<ul style="list-style-type: none"> ■ Used for highlighting smooth surfaces perpendicular to the optical axis by directing the light towards a semi-reflective mirror 	<ul style="list-style-type: none"> ■ Inspecting, analyzing and measuring plane metal surfaces or other reflective surfaces

Fig. 38 : Table showing various lighting systems for industrial vision.

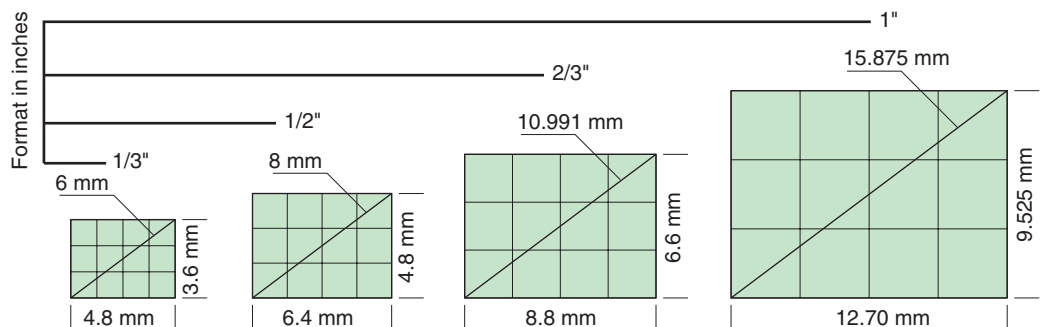


Fig. 39 : Sensor formats used in industry.

■ Scanning

Cameras are either interlaced picture models or progressive scan/full frame types.

Where vibration or image capture on the fly is common, the use of progressive scan (for reading on the fly) or full frame sensors is recommended.

CCD sensors allow the exposure of all pixels at the same moment.

□ Interlaced scan

This system originated from video technology. It involves analyzing an image by scanning odd and even lines alternately (see Fig. 40).

Its aim is to save half the passband, at the cost of some faults, which are poorly visible on a small screen, particularly flicker.

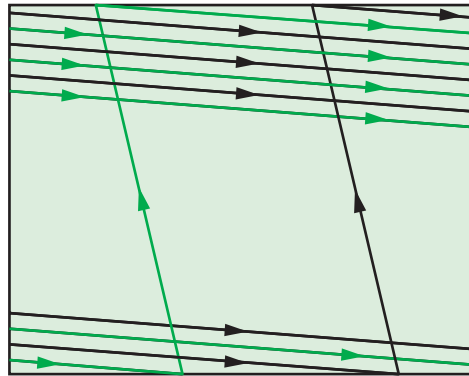


Fig. 40 : Interlaced scanning: A first frame, represented by black lines, analyzes the odd lines, the second, shown in green, analyzes the even lines.

□ Progressive scan

This is the type of image analysis used in information technology. It works on the principle of scanning all the lines of an image at the same time (see Fig. 41). Its advantages are that it

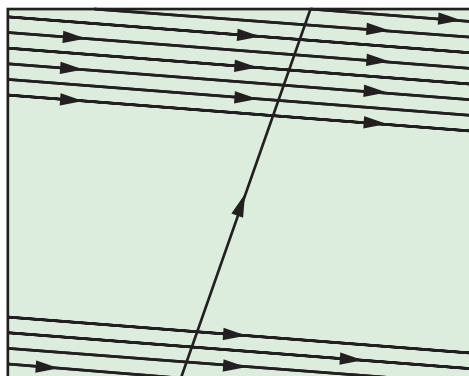


Fig. 41 : Progressive scanning: All lines of an image are scanned at the same time.

suppresses flicker and provides a stable image (see Fig. 42).

■ Lens

□ “C” and “CS” screw mounts with a diameter of 25.4 mm are most commonly used in industry. The focal length (f in mm) is calculated from the height of the object to be framed (H in mm), the distance between the object and the lens (D in mm), and the height of the image (h in mm):

$$f = D \frac{h}{H} \text{ (see Fig. 43) .}$$

$$\text{With a field angle} = 2 \arctg \left(\frac{h}{2f} \right)$$

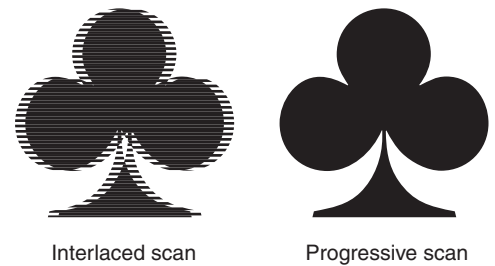


Fig. 42 : Difference in sharpness between the two scanning modes.

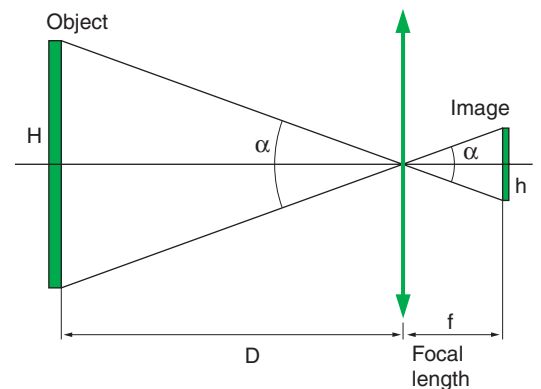


Fig. 43 : Focal length.

Thus, the shorter the focal length, the larger the field.

□ The type of lens is therefore chosen according to the distance D and the size of the field viewed H.

Processing unit

Its electronic systems have two functions: to manipulate the image and then analyze the enhanced image.

■ Image manipulation algorithms

Preprocessing operations change the gray scale value of the pixels. The purpose of these operations is to enhance the image in order to be able to analyze it more effectively and

reliably. The most commonly used preprocessing operations are:

- Binarization
- Projection
- Erosion/dilation
- Opening/closing

■ Image analysis algorithms

The table in **Figure 44** sets out various image analysis algorithms.

Note that the “Prerequisites” column shows the image processing operations, which precede this analysis.

Image analysis algorithm	Operating principle and preferred use (in bold)	Prerequisites	Advantages	Limitations
Line	Pixel/object counting Presence/absence , counting	Binarization and exposure adjustment if necessary	Very fast (< ms)	Binarization can affect image stability
Binary scale zone (black or white)	Pixel counting Presence/absence , surface analysis, intensity check	Binarization and exposure adjustment if necessary	Fast (ms)	Binarization can affect image stability
Gray scale zone	Average gray scale calculation Presence/absence, surface analysis, intensity check	None		
Edge search through binary analysis	Edge location on binary image Measurement, presence/absence, positioning	Binarization and exposure adjustment if necessary		Pixel-level accuracy at best. Binarization can affect image stability
Edge search through gray scale analysis	Edge location on gray scale image Measurement , presence/absence, positioning	None, exposure adjustment if necessary	Used to detect the edges of objects that are damaged or have uneven surfaces. “Smoothing” of objects with irregular surfaces is possible via preprocessing, by calculating the average gray scale of pixels	Requires accurate repositioning.
Shape extraction	Counting , object detection, reading of measurements and geometrical parameters Positioning, repositioning, measurement, sorting , identification	Binarization and exposure adjustment if necessary	Numerous results obtained, versatile. Allows 360° repositioning	Pixel-level accuracy at best. Binarization can affect image stability. Slow (> 10...100 ms)
Shape comparison	Search for shapes similar to prestored models, positioning, repositioning , measurement, sorting, counting, identification	None	Easy to use	Recognition restricted to 30°. Slow (> 10...100 ms) over large template and/or search zone.
OCR/OCV	Recognition of characters (OCR) or verification of characters or logos (OCV)	Good image contrast required. Maximize image size. Use image repositioning	Reads all character or logo types by learning a library (alphabet)	Stability of mark to be inspected can deteriorate over time (e.g. stamped parts)

Fig. 44 : The various image analysis algorithms used in industrial vision.

9 Optical encoders

9.1 Description of an optical encoder

■ Construction

A rotary optical encoder is an angular position sensor comprising a light-emitting diode (LED), a photosensitive receiver, and a disk physically connected by its shaft to the machine controller. The surface of the disk has a series of opaque and transparent zones.

The light emitted by the LEDs is received by photodiodes whenever it passes through the transparent zones of the disk. The photodiodes then generate an electrical signal, which is amplified and then converted into a squarewave signal before being sent to a processing system. When the disk rotates, the encoder output signal is formed from a succession of squarewave signals. **Figure 45** illustrates a typical example.

■ Principles

□ According to the movement of the object to be inspected, the rotation of a graduated disk generates identical pulses at the output of an optical sensor.

The resolution, or the number of pulses per revolution, corresponds to the number of sectors on the disk or to a multiple thereof. The higher the number of points, the higher the number of measurements per revolution, allowing a more accurate division of the movement or the speed of the moving part connected to the encoder.

Typical application: cutting to length

The resolution is expressed by:

$$\frac{\text{distance covered in 1 revolution}}{\text{number of points}}$$

For example, if the product to be cut drives a measuring wheel with a perimeter of 200 mm, for a precision of 1 mm the encoder must have a resolution of 200 points. For a precision of



Fig. 45 : Example of an optical sensor (Telemecanique).

0.5 mm the encoder resolution would have to be 400 points.

■ Practical implementation (see **Fig. 46**)

The emission part comprises a triple light source with three photodiodes or LEDs (for redundancy), with a service life of 10 to 12 years.

An ASIC (Application Specific Integrated Circuit) connected to the sinewave signal optical sensor system produces squarewave signals after amplification.

The disk is made from:

□ Unbreakable POLYFASS (mylar/mica) for resolutions of up to:

- 2048 points with a 40 mm diameter
- 5000 points with a 58 mm diameter
- 10,000 points with a 90 mm diameter

□ GLASS for higher resolutions and high reading frequencies of up to 300 kHz

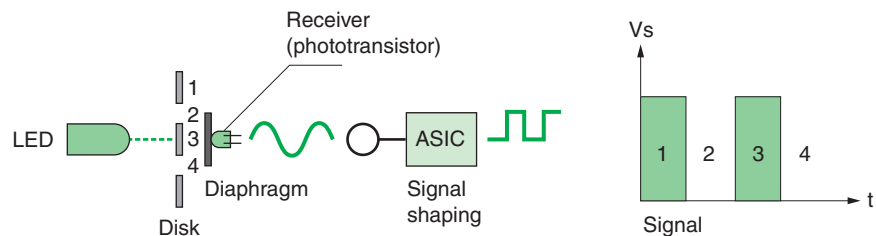


Fig. 46 : Principle of an incremental encoder.

(1) Application Specific Integrated Circuit - circuit intégré spécialisé.

9.2 Optical encoder families

Products are available to cover all industrial applications. There are two main product families:

- Incremental encoders, which can detect the position of a moving part and monitor its movement by incrementing or decrementing the pulses they generate

- Absolute position encoders, which show the exact position over one revolution or several revolutions

These two families include variants such as:

- Absolute multiturn encoders
- Tacho-encoders, which supply additional speed information
- Tachometers, which process data to provide speed information

All these devices use similar techniques. They are differentiated by the windowing of the disks and the way in which the optical signal is encoded or processed.

Incremental encoders (see Fig. 47)

Incremental encoders are designed for positioning and moving part motion control applications. They work by incrementing or decrementing the pulses they generate.

- The disk on an incremental encoder has two types of track:

- An outer track (channels A and B), divided into "n" intervals with equal angles, which are alternately opaque and transparent, "n" being the resolution or number of periods. Two out-of-phase photodiodes positioned behind this track send squarewave signals A and B whenever the light beam passes through a transparent zone. The 90 electrical degree (1/4 of a period) phase shift between signals A and B defines the direction of rotation (see Fig. 48): in one direction, signal B is 1 during the rising edge of A, while in the other direction it is 0.

- An inner track (track Z) with just one transparent window. The Z signal, known as the "zero marker", with a period of 90 electrical degrees, is synchronized with the A and B signals. It defines a reference position and is used for reinitializing after each revolution.

- Using channels A and B

Incremental encoders offer three levels of operating precision:

- Using the rising edges of channel A only: Simple operation, corresponding to the encoder resolution
- Using the rising and falling edges of channel A only: Operational accuracy is doubled
- Using the rising and falling edges of channels A and B: Operational accuracy is quadrupled (see Fig. 49 next page).

- Elimination of interference

Any counting system can be disrupted by interference on the line, which is counted along with the pulses generated by the encoder.

To eliminate this risk, in addition to the signals A, B and Z, most incremental encoders also generate complementary signals A, B and Z. If the processing system is designed to be able to use them (NUM numerical controllers, for example), these complementary signals can be used to differentiate between encoder pulses and interference pulses (see Fig. 50 next page), thus preventing them from being counted, or to reconstruct the emitted signal (see Fig. 51 next page).

Absolute encoders

- Design principle

Absolute encoders are designed for applications monitoring the movement and position of a moving part.

These rotary encoders operate in a similar way to incremental sensors, but differ in the nature of the disk, which has several concentric tracks divided into equal alternating opaque and transparent

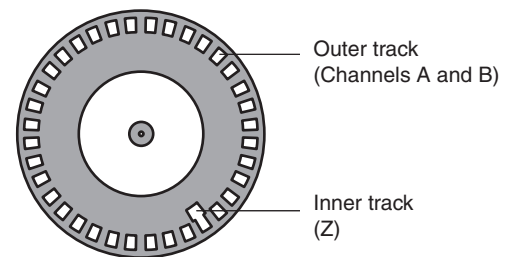


Fig. 47 : View of the graduated disk of an incremental encoder.

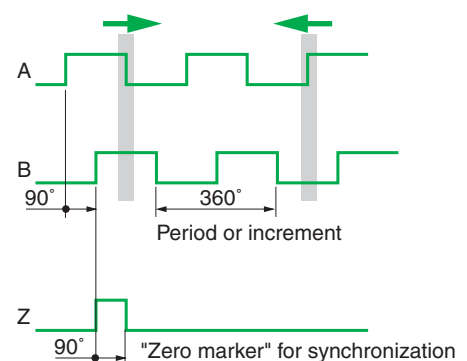
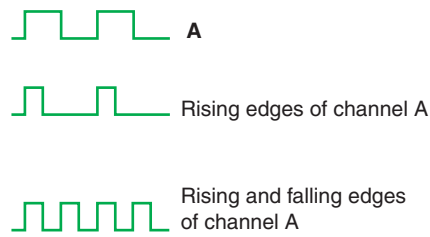


Fig. 48 : Detection principle for direction of rotation and "top zero".

Without signal B



Using signal B

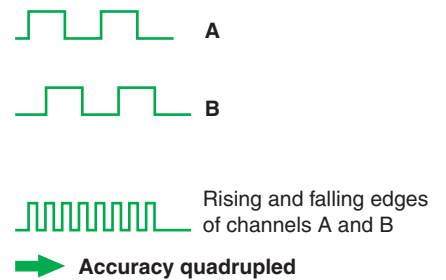
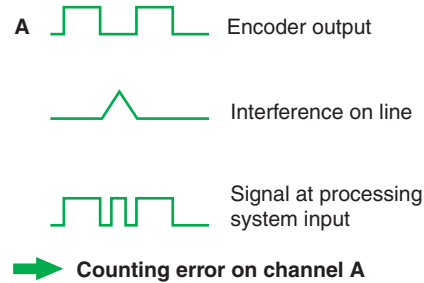


Fig. 49 : Principle for quadrupling the operational accuracy.

No complementary signal



Using a complementary signal

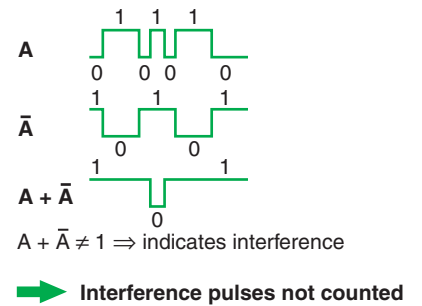


Fig. 50 : Complementary signals are used to differentiate pulses and to prevent stray pulses from being counted.

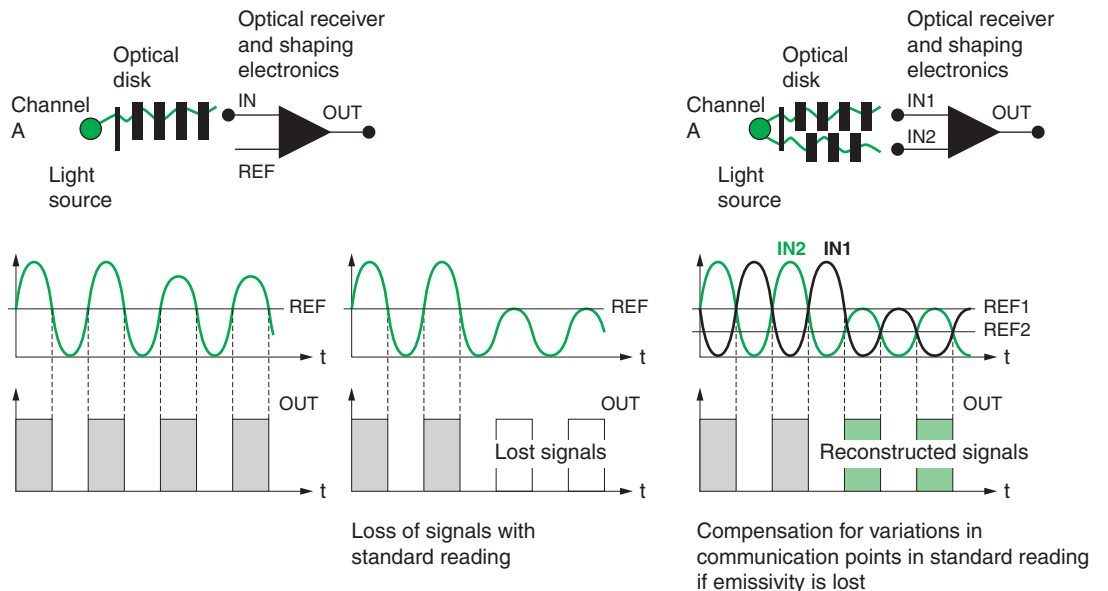


Fig. 51 : Principle for reconstructing an emitted signal.

segments (see Fig. 52 opposite page). An absolute encoder continuously supplies a code, which is the image of the actual position of the moving part being monitored.

The first inner track is half opaque and half transparent. Reading this track allows the

position of the object to be identified in about half a revolution (MSB: Most Significant Bit).

The next tracks, from the center out towards the edge of the disk, are divided into 4 alternating opaque and transparent quarters. Reading the second track in combination with the preceding

track (first track) thus determines in which quarter of a revolution (1/4 or 1/2) the object is located. The following tracks identify successively in which eighth (1/8 or 1/2) of a revolution, sixteenth (1/16) of a revolution, etc., it is located. The outer track corresponds to the lowest-order bit (LSB: Least Significant Bit).

The number of parallel outputs is the same as the number of bits or tracks on the disk. The image of the movement requires as many diode/photo-transistor pairs as there are bits emitted or tracks on the disk. The combination of all the signals at a given moment gives the position of the moving part.

Absolute encoders produce a digital code, which is the image of the physical position of the disk, where a single code corresponds to a single position. The code produced by an absolute rotary encoder can be either natural binary (pure binary) or reflected binary, also known as Gray code (see Fig. 53).

■ Advantages of absolute encoders

Absolute encoders offer two key advantages over incremental encoders:

- They are tolerant of line supply failures because on start-up or after a supply failure, the

encoder supplies a data item corresponding to the actual angular position of the moving part, which can be used immediately by the processing system. Incremental encoders, on the other hand, have to be reinitialized before the signals can be used effectively.

- They are insensitive to line interference. Interference can modify the code produced by an absolute encoder, but this code corrects itself automatically as soon as the interference disappears. With an incremental encoder, interference data is taken into account, unless complementary signals are used.

■ Using the signals

For each angular position of the shaft, the disk supplies a code, which may either be a binary code or a Gray code:

- Pure binary code
Allows the 4 arithmetic operations to be performed on numbers expressed in this code. It can therefore be used directly by processing systems (PLCs) to perform calculations.

However, it has the disadvantage of having several bits, which change state between two positions, giving rise to possible ambiguity in the reading.

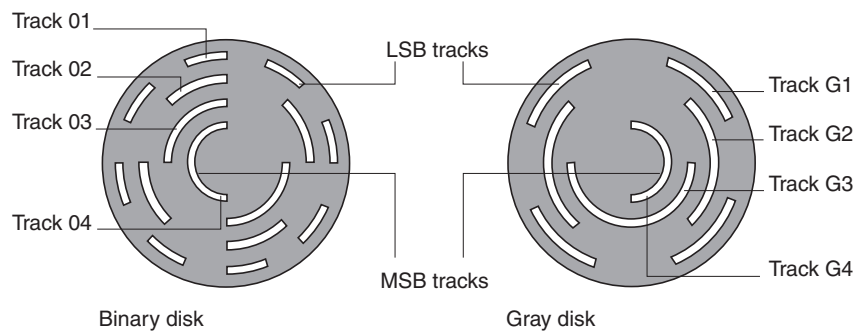


Fig. 52 : Etched disks from an absolute encoder.

Optical reading of disk

Values	0	1	2	3	4	5	6	7	8	9	10	11	12	13	14	15
2^0	0	1	1	0	0	1	1	0	0	1	1	0	0	1	1	0
2^2	0	0	1	1	1	1	0	0	0	0	1	1	1	1	0	0
2^4	0	0	0	0	1	1	1	1	1	1	1	1	0	0	0	0
2^8	0	0	0	0	0	0	0	0	1	1	1	1	1	1	1	1
2^{16}	0	0	0	0	0	0	0	0	0	0	0	0	0	0	0	0

Signal produced by sensor

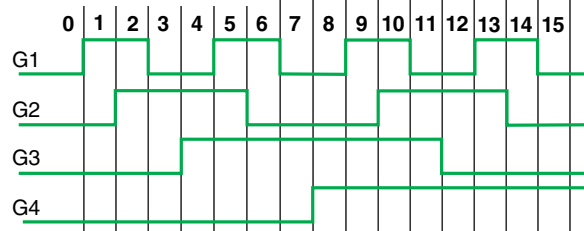


Fig. 53 : Signal produced in Gray code by a rotary absolute encoder.

To eliminate this ambiguity, absolute encoders generate an inhibit signal, which blocks the outputs on every change of state.

□ Gray code, in which only one bit changes state at a time, also avoids this ambiguity.

In order to be used by a PLC, however, the code must first be converted to binary (see Fig. 54).

■ Using an absolute encoder

In most applications, the quest for greater productivity demands rapid movements, at high speed, followed by deceleration to obtain accurate positioning.

In order to achieve this objective with standard I/O cards, only the MSBs need to be monitored

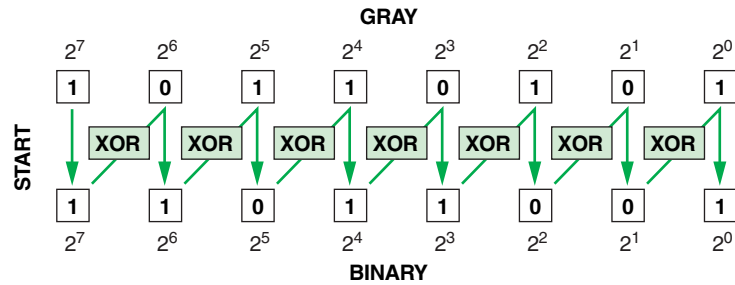


Fig. 54 : Principle of converting Gray into binary.

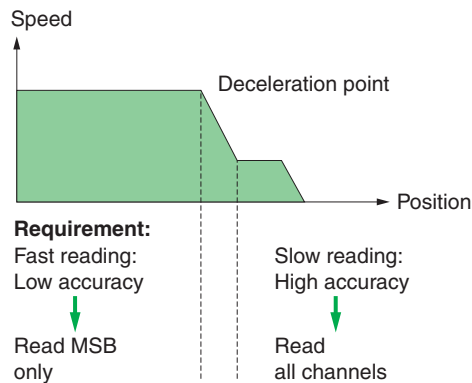


Fig. 55 : Position of a moving part along an axis.

when the speed is high, allowing deceleration to be initiated at about half a revolution (see Fig. 55).

Encoder variants

Many variants have been designed, and a number of different types are available to meet the needs of various applications, including:

- Absolute multiturn encoders
- Tacho-encoders and tachometers
- Solid-shaft encoders
- Hollow-shaft encoders
- Thru-shaft encoders

9.3 Using an encoder with a processing unit

The input circuits on the processing units must be compatible with the flow of data supplied by the encoders (see Fig. 56).

Processing units		Encoders			
		Incremental			Absolute
		Signal frequency (kHz)			Parallel connection
		≤ 0.2	≤ 40	> 40	
PLCs	Discrete inputs	■			■
	Fast counting Axis cards	■	■		
Numerical controllers		■	■	■	
Microprocessors	Parallel inputs				■
Special cards		■	■	■	■

Fig. 56 : Main types of processing units used in industry and the encoders with which they are generally used.

10 Pressure switches and vacuum switches

10.1 What is pressure?

Pressure is the result of a force applied to an area. If P is the pressure, F the force and A the area, we get the relation $P = \frac{F}{S}$.

The earth is surrounded by a layer of air, which has a certain mass and thus exerts a certain pressure known as “atmospheric pressure”, which at sea level is equal to 1 bar.

Atmospheric pressure is expressed in hPa (hectopascal) or mbar. 1 hPa = 1 mbar.

The international unit of pressure is the Pascal (Pa): 1 Pa = 1 N/m²

A more practical unit is the bar:
1 bar = 10⁵ Pa = 10⁵ N/m² = 10 N/cm²

Pressure switches, vacuum switches and pressure transmitters are used to monitor, control or measure a pressure or vacuum in a hydraulic or pneumatic circuit.

Pressure switches or vacuum switches convert a change in pressure to a discrete electrical signal

when the displayed setpoints are reached. They can be based on electromechanical or electronic technology (see Fig. 57).

Pressure transmitters (also known as analog sensors) convert the pressure to a proportional electrical signal and are based on electronic technology.

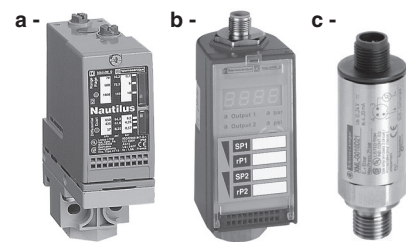


Fig. 57 : Example of pressure sensors (Telemecanique), [a] electromechanical pressure switch, [b] electronic pressure switch, [c] pressure transmitter.

10.2 Pressure control sensors

Principle

These electromechanical devices utilize the movement of a diaphragm, piston or bellows to actuate electrical contacts mechanically (see Fig. 58).

Telemecanique electronic pressure sensors have a piezoresistive ceramic cell (see Fig. 59).

The deformation due to pressure is transmitted to the “thick-film” resistors on the Wheatstone bridge screen-printed onto the ceramic diaphragm. The change in resistance is then processed by the integrated electronics to give a discrete signal or a signal that is proportional to the pressure (e.g. 4-20 mA, 0-10 V, etc.).

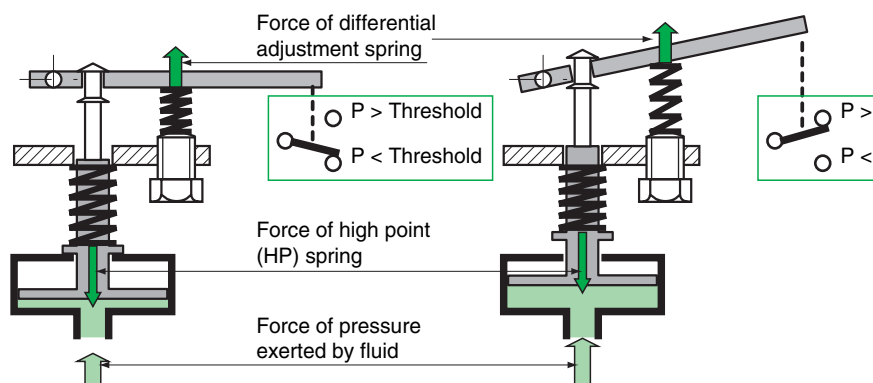


Fig. 58 : Principle of an electromechanical pressure sensor (Telemecanique).

The pressure control or measurement is based on the difference between the pressures prevailing on both sides of the element subjected to the pressure. Depending on the reference pressure, the following terminology is used:

Absolute pressure: Measurement in relation to a sealed volume, generally vacuum

Relative pressure: Measurement in relation to atmospheric pressure

Differential pressure: Measurement of the difference between two pressures

Note that the electrical output contacts can be:

- Power, 2-pole or 3-pole contacts, for direct control of single-phase or three-phase motors (pumps, compressors, etc.)
- Or standard contacts, for control of contactor coils, relays, solenoid valves, PLC inputs, etc.

Terminology (see Fig. 60)

■ General terminology

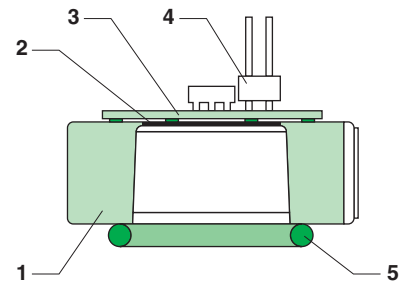
□ **Operating range**

This is the interval defined by the minimum low point (LP) adjustment value and the maximum high point (HP) adjustment value for pressure switches and vacuum switches. It corresponds to the measuring range for pressure transmitters (also known as analog sensors). Note that the pressure values displayed on the devices are based on atmospheric pressure.

NB: In Telemecanique documents the markers are PB (Point Bas in French) for LP (low point) and PH (Point Haut in French) for HP (high point)

□ **Adjustment range**

This is the interval defined by the minimum and the maximum high point adjustment value.



- (1) Ceramic cell with measuring diaphragm
- (2) Measuring diaphragm
- (3) Amplification electronics
- (4) Electrical connexion
- (5) Seal

Fig. 59 : Cross-section of a pressure sensor (Telemecanique).

□ **Size**

Maximum working range value for pressure switches.

Minimum working range value for vacuum switches.

□ **High setpoint (HP)**

This is the maximum pressure value selected and set on the pressure switch or vacuum switch at which the output changes state when the pressure is increasing.

□ **Low setpoint (LP)**

This is the minimum pressure value selected or set on the pressure switch or vacuum switch at which the output changes state when the pressure is decreasing.

□ **Differential**

This is the difference between the high setpoint (HP) and the low setpoint (LP).

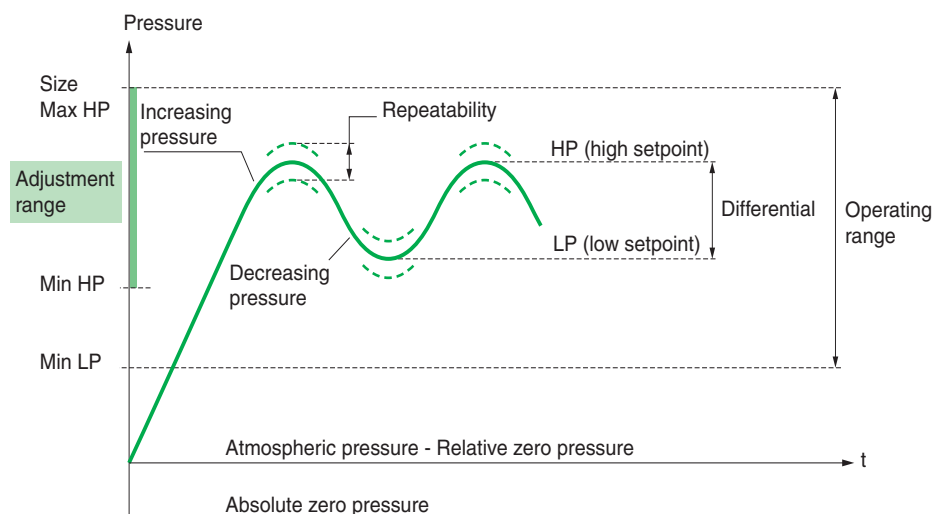


Fig. 60 : Graphical representation of commonly used terms.

□ **Fixed differential devices**

The low point (LP) is directly linked to the high point (HP) by the differential.

□ **Adjustable differential devices**

The low point (LP) can be fixed by adjusting the differential.

■ Terminology specific to electromechanical devices (see Fig. 61)

□ **Accuracy of setpoint display**

This is the tolerance between the displayed setpoint value and the actual value at which the contact is activated. For an accurate setpoint (first installation of product), use the reference from a calibrating device (ex.: manometer).

□ **Repeatability (R)**

This is the variation in the operating point between two successive operations.

□ **Drift (F)**

This is the variation in the operating point over the entire lifetime of the device.

■ Terminology specific to electronic devices

□ **The measuring range (MR)** for a pressure transmitter corresponds to the interval between the pressure values measured by the transmitter. It goes from 0 bar to the pressure corresponding to the transmitter rating.

□ **Accuracy** comprises linearity, hysteresis, repeatability, and adjustment tolerances.

It is expressed as a percentage of the measuring range of the pressure transmitter (% MR).

□ **Linearity** is the greatest difference between the actual transmitter curve and the nominal curve (see Fig. 62).

□ **Hysteresis** is the greatest difference between the increasing pressure curve and the decreasing pressure curve (see Fig. 62).

□ **Repeatability** is the maximum scatter band obtained by varying the pressure under specified conditions (see Fig. 62).

□ **Adjustment tolerances** are the tolerances for zero point adjustment and sensitivity adjustment as specified by the manufacturer (gradient of the curve of the transmitter's output signal).

□ **Temperature drifts** (see Fig. 63)

The accuracy of a pressure sensor is always sensitive to the operating temperature. These drifts proportional to the temperature are expressed as % MR/K and particularly regard zero point and sensitivity.

□ **Maximum permissible cycle pressure (Ps)**

This is the pressure that the sensor can withstand without damage in every cycle over its lifetime. It is equal to at least 1.25 times the rating of the device.

□ **Maximum permissible accidental pressure**

This is the maximum pressure, excluding pressure surges, to which the pressure sensor can occasionally be subjected without being damaged.

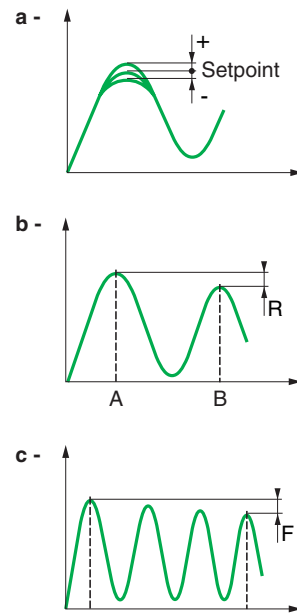


Fig. 61 : Graphical representation of terms specific to electromechanical devices, [a] setpoint accuracy, [b] repeatability between two operations A and B, [c] drift, or variation in operating point over the entire lifetime of the device.

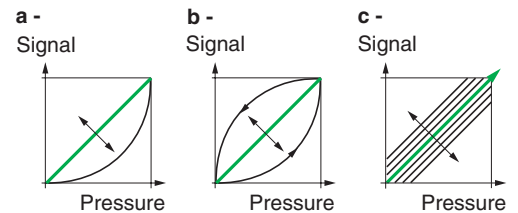


Fig. 62 : Graphical representation of: [a] linearity, [b] hysteresis, [c] repeatability.

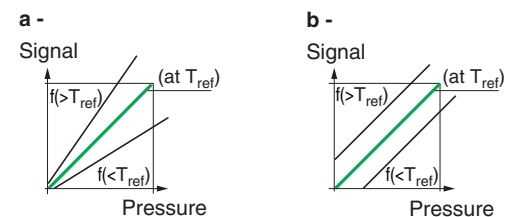


Fig. 63 : Graphical representation of: [a] sensitivity temperature drift, [b] zero point temperature drift.

□ **Desctruction pressure**

This is the pressure above which the pressure sensor is at risk of developing a leak or bursting. These pressure-related definitions are all essential when choosing the most appropriate sensors for a specific application, and in particular for ensuring that they are suitable for use in hydraulic circuits, which are subject to severe transient phenomena such as water hammer.

11 Other characteristics of presence detectors

The various different detection technologies have been described in this document.

Each has its own advantages and limitations.

In choosing a particular technology, other criteria must also be taken into consideration. These are set out in selection tables in manufacturers' catalogs. Among these criteria, and depending on the type of detector, the following are of particular relevance:

- Electrical characteristics
- Environmental conditions
- Possibilities and ease of installation

The paragraphs below provide examples of criteria, which, without being central to the basic function, offer advantages for operation and use.

Electrical characteristics

- The supply voltage, AC or DC, the range for which will vary
- 2-wire or 3-wire load switching method (see Fig. 64)

Both these methods are common to many manufacturers, but it is important to pay particular attention to residual currents and voltage drops across the sensor terminals: low values will ensure better compatibility with all load types.

Environmental conditions

- Electrical
 - Immunity to line interference
 - Immunity to radio frequencies
 - Immunity to electric shocks
 - Immunity to electrostatic discharge
- Thermal

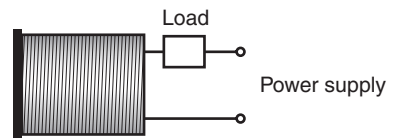
Generally from -25 to +70°C but according to detectors and their manufacturers up to -40 to +120°C

- Moisture/dust

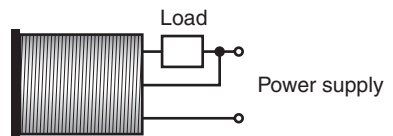
Degree of protection of enclosure (seal): e.g. IP 68 for a detector involving machine tools that use cutting oil

Possibility/ease of installation

- Geometric shape (cylindrical or block type)
- Metal/plastic casing
- Suitability for flush-mounting in a metal frame
- Fixing mechanisms
- Connection, by cable or connector
- Self-teach functions



2-wire method: The sensor is supplied in series with the load, so it is subject to a residual current in the open state and a voltage drop when in the closed state. The output can be normally open or normally closed (NO/NC). And the maximum intensity of the switched current at the AC or DC output is higher or lower, with or without short-circuit protection.



3-wire method: The sensor has two feed wires and one wire for transmitting the output signal (or more in the case of multiple-output products). The output can be a transistorized PNP or NPN output.

Fig. 64 : Load switching methods.

12 Conclusion

What does the future hold?

The performance of electronic sensors is set to improve still further, thanks to developments in electronics in terms of both the electrical characteristics of the components and their dimensions.

With the boom in telecommunications (internet, cell phones), the operating frequencies of electronic devices have increased, from a few hundred MHz to GHz. This makes it easier to measure wave propagation speeds, for example, and hence to eliminate local physical phenomena. Furthermore, technologies such as Bluetooth and WIFI open up the possibility of producing wireless sensors, with radio links at frequencies in the order of 2.4 GHz.

Another benefit of modern electronics lies in digital signal processing: the falling cost of microcontrollers allows simple sensors to be given sophisticated functions (automatic adjustment to the environment with detection of moisture, smoke or nearby metallic elements, "intelligent" sensor with self-test capabilities).

Thanks to these technological advances, electronic sensors will be more suitable for initial

requirements and more easily adjustable to process changes ... while the cost will remain virtually unchanged. These innovations call for major investment, however, which only the biggest sensor manufacturers are currently able to afford.

The importance of sensors

All designers and users of automatic systems, from a simple garage door to a production line, know that the smooth running of an automation system depends on the choice of detectors, which contribute to:

- The safety of people and property
- The reliability of an automation system in an industrial process
- Optimized control of industrial equipment
- Control of operating costs

But these sensors have particular requirements in terms of use and operation, requirements, which are specific to their technologies as described in this "Cahier Technique".

This guide should give you a better understanding of the operating limits and required settings for all these sensors.

Schneider Electric

Direction Scientifique et Technique,
Service Communication Technique
F-38050 Grenoble cedex 9

E-mail : fr-tech-com@schneider-electric.com

DTP: Axess
Transl.: Lloyd International - Tarporley - Cheshire - GB
Editor: Schneider Electric